



Info prodotto 2003.1

25.05.2020

INCOLLAGGIO E SIGILLATURA DEGLI ANGOLI

Per la corretta chiusura degli angoli si consiglia di seguire scrupolosamente tutte le indicazioni contenute in questa info-prodotto. Al fine di rendere l'operazione agevole ed efficace abbiamo selezionato l'attrezzatura migliore per la sua esecuzione.

Si sottolinea come l'incollaggio e la sigillatura degli angoli siano operazioni fondamentali per garantire la qualità del manufatto e la sua resistenza nel tempo.









Dopo aver tagliato i profili, eseguito la lavorazione per l'utilizzo delle squadrette e il foro per iniettare la colla (come indicato nel "Manuale Costruzione finestre battenti"), **è necessario effettuare le seguenti lavorazioni:**

1. Sigillare le superfici di contatto dei profili tagliati utilizzando l'apposita sigillatrice (pagina 3);
2. Assemblare i profili utilizzando le apposite squadrette (pagina 4);
3. Serrare le squadrette (pagina 5);
4. Iniettare la colla per il fissaggio degli angoli tramite il foro preposto (pagina 6).

A seguire riportiamo l'elenco dei **nuovi accessori**, delle attrezzature consigliate e la procedura in dettaglio.

EasyDoor	●
Ecoslim 50 TT	●
Ecoslim 62 TT	●
Ecoslim 72 TT	●
Elite Door 72	●
Door 62	●
Door 72	●
Sirio 50	●
Smart 30	●
Planet 45	●
Planet 50 TT	●
Planet 50 PLUS	●
Planet 62 TT	●
Planet 62 PLUS	●
Planet 72 HT	●
Planet 72 PLUS	●
3G	●
Fullglazing	●
Matic 50	●
Matic 50 PLUS	●
Matic 62 TT	●
Matic 62 PLUS	●
Matic 72	●
Matic 72 PLUS	●
3G Matic	●
Nathura 59	●
Nathura 70	●
Nathura 82	●
Nathura 92	●
Slide 60	●
Slide 65	●
Slide 80/106 PLUS	●
Topslide 160	●
Topslide 160 PLUS	●
Slidewood 160	●
Topslidewood 214	●
Panoramico	
Balconi e balaustre	

INCOLLAGGIO E SIGILLATURA DEGLI ANGOLI

	<p>AGP 5058</p> <p>Sigillante poliuretano bicomponente, cartuccia 415ml</p>		<p>AGP 5079</p> <p>Pistola a batteria per sigillante bicomponente AGP 5058</p>
	<p>AGP 5059</p> <p>Pistola manuale per sigillante bicomponente AGP 5058</p>		<p>AGP 5072</p> <p>Beccuccio Static Mixer per AGP 5058</p>
	<p>AGP 5069</p> <p>Pistola pneumatica per sigillante bicomponente AGP 5058</p>		<p>MCT PL TKE 259</p> <p>Sigillatrice d'angoli automatica</p>
	<p>ACP 50127</p> <p>Squadretta allineamento da incollare</p>		<p>AGP 5073</p> <p>Sigillante per sigillatrice MCT PL TKE 259</p>

● EasyDoor	● Ecoslim 50 TT	● Ecoslim 62 TT	● Ecoslim 72 TT	● Elite Door 72	● Door 62	● Door 72	● Sirio 50	● Smart 30	● Planet 45	● Planet 50 TT	● Planet 50 PLUS	● Planet 62 TT	● Planet 62 PLUS	● Planet 72 HT	● Planet 72 PLUS	● 3G	● Fullglazing	● Matic 50	● Matic 50 PLUS	● Matic 62 TT	● Matic 62 PLUS	● Matic 72	● Matic 72 PLUS	● 3G Matic	● Nathura 59	● Nathura 70	● Nathura 82	● Nathura 92	● Slide 60	● Slide 65	● Slide 80/106 PLUS	● Topside 160	● Topside 160 PLUS	● Slidewood 160	● Topslidewood 214	● Panoramico	● Balconi e balaustre
------------	-----------------	-----------------	-----------------	-----------------	-----------	-----------	------------	------------	-------------	----------------	------------------	----------------	------------------	----------------	------------------	------	---------------	------------	-----------------	---------------	-----------------	------------	-----------------	------------	--------------	--------------	--------------	--------------	------------	------------	---------------------	---------------	--------------------	-----------------	--------------------	--------------	-----------------------



Info prodotto 2003.1

25.05.2020

it's my window

1

Sigillare i profili: prima di chiudere l'angolo, sigillare le superfici di contatto dei profili tagliati, utilizzando l'apposita sigillatrice.



Sigillatrice d'angoli automatica

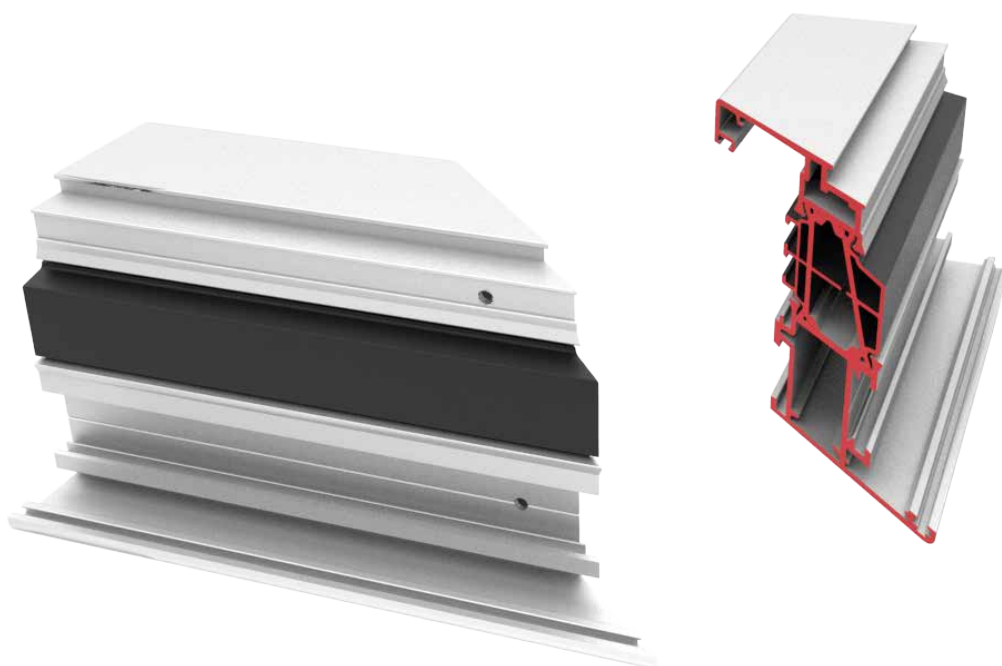

● EasyDoor
● Ecoslim 50 TT
● Ecoslim 62 TT
● Ecoslim 72 TT
● Elite Door 72
● Door 62
● Door 72
● Sirio 50
● Smart 30
● Planet 45
● Planet 50 TT
● Planet 50 PLUS
● Planet 62 TT
● Planet 62 PLUS
● Planet 72 HT
● Planet 72 PLUS
● 3G
● Fullglazing
● Matic 50
● Matic 50 PLUS
● Matic 62 TT
● Matic 62 PLUS
● Matic 72
● Matic 72 PLUS
● 3G Matic
● Nathura 59
● Nathura 70
● Nathura 82
● Nathura 92
● Slide 60
● Slide 65
● Slide 80/106 PLUS
● Topslide 160
● Topslide 160 PLUS
● Slidewood 160
● Topslidewood 214
● Panoramico
● Balconi e balaustre

Info prodotto 2003.1

25.05.2020

2

Assemblare telaio e ante tramite le apposite squadrette di sistema

1 Inserire le squadrette

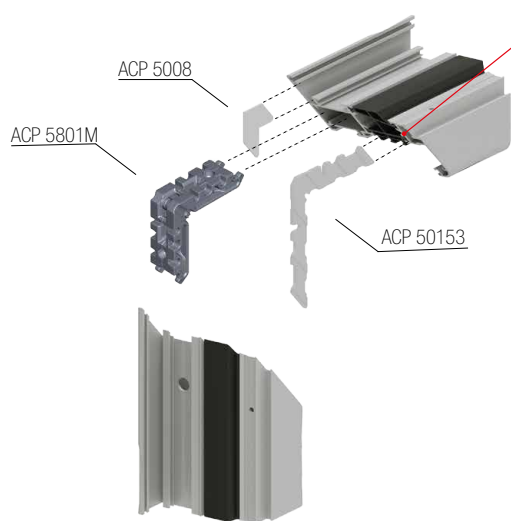

Iniettare colla solo nella tubolarità esterna prima di inserire la squadretta

2 Chiudere l'angolo utilizzando gli strumenti in base alla tipologia di squadretta scelta

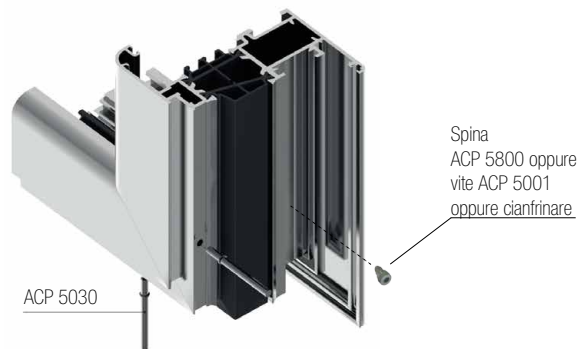

3 Inserire squadretta di allineamento esterna

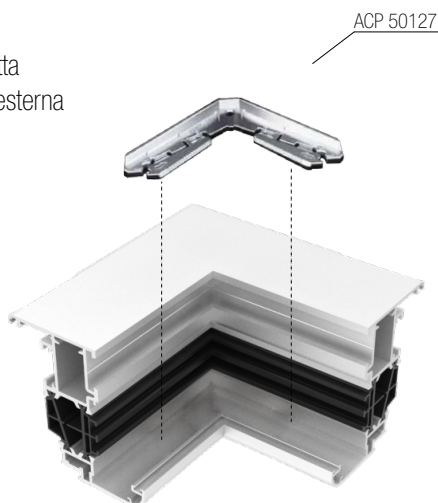

ALsistem consiglia...

di utilizzare la squadretta multifunzione nella tubolarità interna per avere una miglior qualità del prodotto finito e le spine ACP 5030 con impugnatura a perdere, nella tubolarità esterna.

● EasyDoor
● Ecoslim 50 TT
● Ecoslim 62 TT
● Ecoslim 72 TT
● Elite Door 72
● Door 62
● Door 72
● Sirio 50
● Smart 30
● Planet 45
● Planet 50 TT
● Planet 50 PLUS
● Planet 62 TT
● Planet 62 PLUS
● Planet 72 HT
● Planet 72 PLUS
● 3G
● Fullglazing
● Matic 50
● Matic 50 PLUS
● Matic 62 TT
● Matic 62 PLUS
● Matic 72
● Matic 72 PLUS
● 3G Matic
● Nathura 59
● Nathura 70
● Nathura 82
● Nathura 92
● Slide 60
● Slide 65
● Slide 80/106 PLUS
● Topslide 160
● Topslide 160 PLUS
● Slidewood 160
● Topslidewood 214
● Panoramico
● Balconi e balaustre

Info prodotto 2003.1

25.05.2020

3

Serraggio squadrette ACP 50127: precaricare e chiudere le squadrette da entrambi i lati tramite un cacciavite a taglio ruotando secondo il verso indicato sulla squadretta.

1 Precarico



2 Chiusura



● EasyDoor
● Ecoslim 50 TT
● Ecoslim 62 TT
● Ecoslim 72 TT
● Elite Door 72
● Door 62
● Door 72
● Sirio 50
● Smart 30
● Planet 45
● Planet 50 TT
● Planet 50 PLUS
● Planet 62 TT
● Planet 62 PLUS
● Planet 72 HT
● Planet 72 PLUS
● 3G
● Fullglazing
● Matic 50
● Matic 50 PLUS
● Matic 62 TT
● Matic 62 PLUS
● Matic 72
● Matic 72 PLUS
● 3G Matic
● Nathura 59
● Nathura 70
● Nathura 82
● Nathura 92
● Slide 60
● Slide 65
● Slide 80/106 PLUS
● Topslide 160
● Topslide 160 PLUS
● Slidewood 160
● Topslidewood 214
● Panoramico
● Balconi e balaustre

Info prodotto 2003.1

25.05.2020

4

Incollaggio squadrette ACP 50127: iniettare la colla AGP 5058 fino al riempimento delle scanalature predisposte.

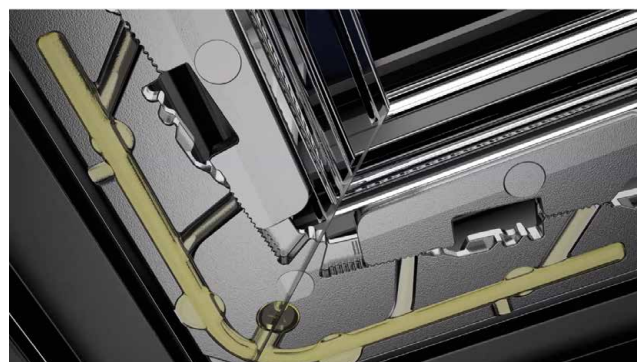

5

Iniettare la colla AGP 5058, anche nella squadretta interna ACP 5801M, attraverso il foro preposto, fino al riempimento di tutte le cavità dell'angolo interno.



ALsistem consiglia...

l'utilizzo della colla bicomponente AGP 5058 per garantire una maggior tenuta e velocizzare la solidificazione dell'angolo



● EasyDoor
● Ecoslim 50 TT
● Ecoslim 62 TT
● Ecoslim 72 TT
● Elite Door 72
● Door 62
● Door 72
● Sirio 50
● Smart 30
● Planet 45
● Planet 50 TT
● Planet 50 PLUS
● Planet 62 TT
● Planet 62 PLUS
● Planet 72 HT
● Planet 72 PLUS
● 3G
● Fullglazing
● Matic 50
● Matic 50 PLUS
● Matic 62 TT
● Matic 62 PLUS
● Matic 72
● Matic 72 PLUS
● 3G Matic
● Nathura 59
● Nathura 70
● Nathura 82
● Nathura 92
● Slide 60
● Slide 65
● Slide 80/106 PLUS
● Topslide 160
● Topslide 160 PLUS
● Slidewood 160
● Topslidewood 214
● Panoramico
● Balconi e balaustre