

## Info prodotto 1902.1

26.03.2019

# SOLUZIONE T all'italiana

## Applicazione tappo ACP 50121M

Riportiamo le indicazioni per la realizzazione della **soluzione T all'italiana** del sistema Planet 62 PLUS. Di seguito troverete:

1. Distinta taglio > pagina 2 di 7;
2. Lavorazioni da effettuare sui profili > da pagina 3 di 7;
3. Montaggio tappo ACP 50121M > da pagina 5 di 7.

Con l'occasione vi ricordiamo che la soluzione è valida anche per il sistema Fullglazing di cui alleghiamo, a pagina 6 e 7, il nodo e la lavorazione (pagina 311 del catalogo).

### PLANET 62 PLUS

NODO FUORI SCALA

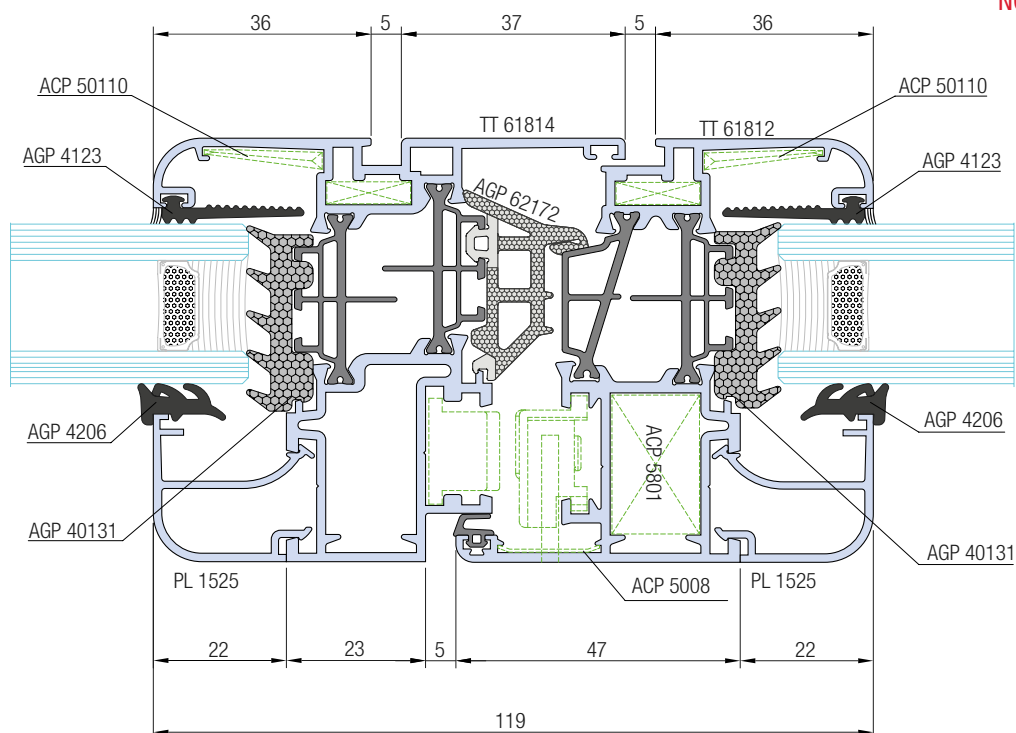

### NODO CENTRALE - APERTURA INTERNA

EasyDoor	Elite Door 72	Door 62	Door 72	Sirio 50	Smart 30	Planet 45	Planet 50 TT	Planet 50 PLUS	Planet 62 TT	Planet 62 PLUS	Planet 72 HT	Planet 72 PLUS	3G	Fullglazing	Matic 50	Matic 50 PLUS	Matic 62 TT	Matic 62 PLUS	Matic 72	Matic 72 PLUS	Nathura 59	Nathura 70	Nathura 82	Nathura 92	Slide 60	Slide 65	Slide 80/106 PLUS	Topslide 160	Slidewood 160	Topslidewood 214	Panoramico	Balconi e balaustre	
										●				●																			

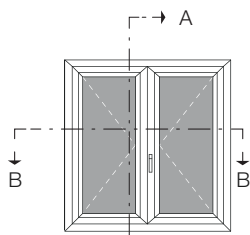

2 leaves window

Finestra 2 ante

Glass list

Distinta vetri

Pezzi	L	H
2	L/2-116.5	H-134

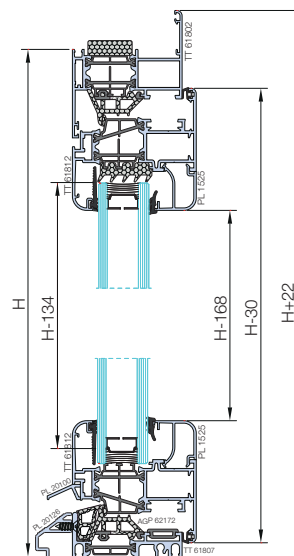

Sez. A-A

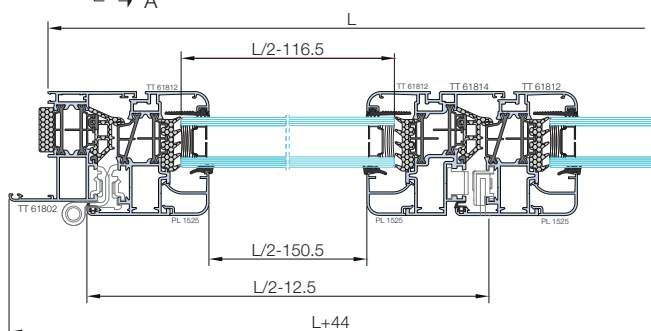

Sez. B-B

Profiles' list

Art.	Descrizione	Pezzi	Misura	Taglio
TT 61802	Traverso telaio <i>transom frame</i>	1	L+44	
	Montante telaio <i>mullion frame</i>	2	H+22	
TT 61807	Soglia ribassata 25mm <i>lowered threshold</i>	2	L-47	
TT 61812	Traverso anta <i>transom leaf</i>	4	L/2-12.5	
	Montante anta <i>mullion leaf</i>	3	H-30	
TT 61814	Montante T italiana <i>T-italian mullion</i>	1	H-12	
PL 1525	Traverso fermavetro <i>transom glazing bead</i>	4	L/2-150.5	
	Montante fermavetro <i>mullion glazing bead</i>	4	H-168	
PL 2016	Rinforzo soglia ribassata <i>low threshold support</i>	1	L	
PL 20100	Gocciolatoio <i>drip fin</i>	1	L-100	

Gaskets' list

Art.	Descrizione	Pezzi	Misura
AGP 4000	Battuta <i>wall seal</i>	3 3	L/2-24.5 H-30
AGP 40131	Sottovetro <i>glazing strip</i>	4 4	L/2-96.5 H-114
AGP 5034/25	Isolamento muro <i>wall insulation</i>	1 2	L H
AGP 5037	Isolamento muro <i>wall insulation</i>	1	L
AGP 62172	Pinna giunto aperto <i>central beat</i>	2 3	L-124 H-110
Dipende dal vetro	Vetro esterno <i>external glass gasket</i>	4 4	L/2-116.5 H-134
Dipende dal vetro	Vetro interno <i>internal glass gasket</i>	4 4	L/2-116.5 H-134
AGP 6502	Guarnizione supplementare <i>addition gasket</i>	1	L

Accessories' list

Art.	Descrizione	Q.tà
ACP 5801	Squadretta multifunzione <i>corner cleat</i>	10 pz
ACP 5001	Vite per squadretta <i>screw for corner cleat</i>	20 pz
ACP 5008	Squadretta all. inox <i>inox corner cleat</i>	8 pz
ACP 50110	Squadretta all. eccentrico <i>alignment corner cleat with tightening eccentrics</i>	8 pz
ACP 50153	Squadretta cianfrinare est. <i>alignment corner bracket</i>	10 pz
ACP 5030	Spina ø3mm <i>Ø3 mm pin</i>	20 pz
ACP 5005	Cerniera <i>hinge for flat frame</i>	4 pz
ACP 50150	Kit anta ribalta <i>tilt &amp; turn set</i>	1 kit
ACP 5045	Blocchetti collegamento <i>connection pieces</i>	1 cp
ACP 5025	Terminale asta <i>rod terminal</i>	2 pz
ACP 5024	Incontro zama <i>zamak keeper double rod</i>	2 pz
ACP 5022	Catenacciolo <i>bolt</i>	2 pz
ACP 5052	Kit catenaccioli <i>metal bolts kit</i>	1 kit
ACP 50539	Regolo muro obliquo <i>oblique wall spacer</i>	6/8 pz
AGP 62185	Angolo vulcanizzato <i>vulcanized corner</i>	4 pz
ACP 50200	Cremonese Aurora <i>cremonese Aurora</i>	1 pz
ACP 5014	Angoletto fermavetro <i>glazing bead corner</i>	8 pz
ACP 50121M	Tappo di riporto <i>plug for central connection profile</i>	1 cp

# Info prodotto 1902.1

26.03.2019

## SOLUZIONE T all'italiana

### Applicazione tappo ACP 50121M

#### PLANET 62 PLUS

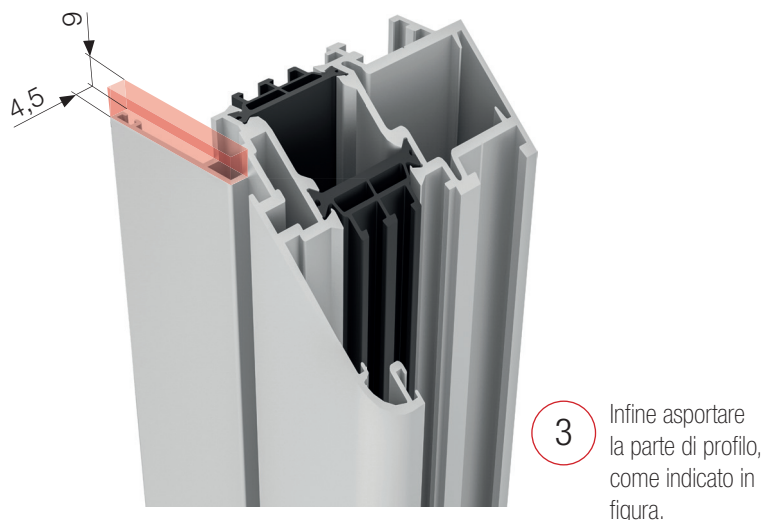
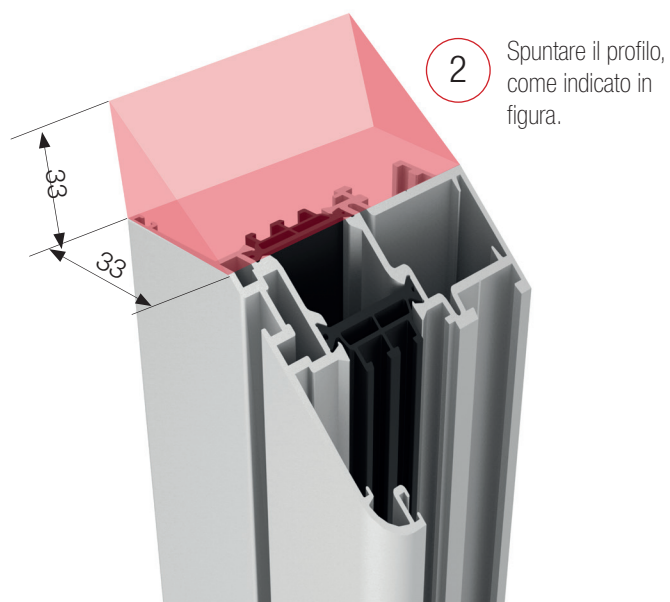
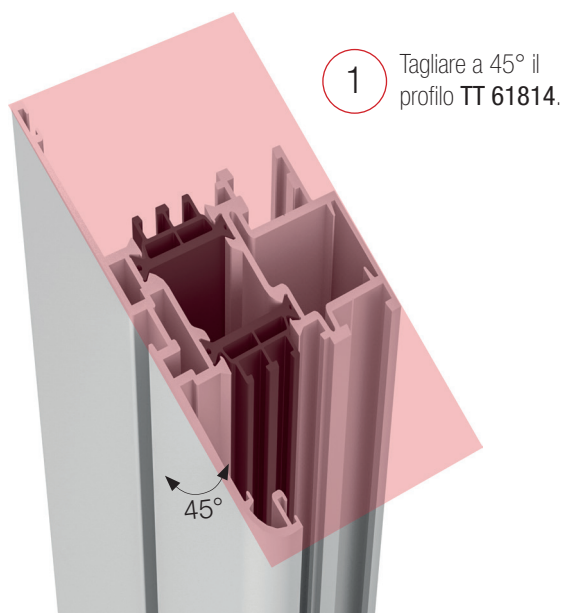

EasyDoor	Elite Door 72	Door 62	Door 72	Sirio 50	Smart 30	Planet 45	Planet 50 TT	Planet 50 PLUS	Planet 62 TT	Planet 62 PLUS	Planet 72 HT	Planet 72 PLUS	3G	Fullglazing	Matic 50	Matic 50 PLUS	Matic 62 TT	Matic 62 PLUS	Matic 72	Matic 72 PLUS	Nathura 59	Nathura 70	Nathura 82	Nathura 92	Slide 60	Slide 65	Slide 80/106 PLUS	Topslide 160	Slidewood 160	Topslidewood 214	Panoramico	Balconi e balaustre		
										●				●																				



## Info prodotto 1902.1

26.03.2019

# SOLUZIONE T all'italiana

## Applicazione tappo ACP 50121M

### PLANET 62 PLUS

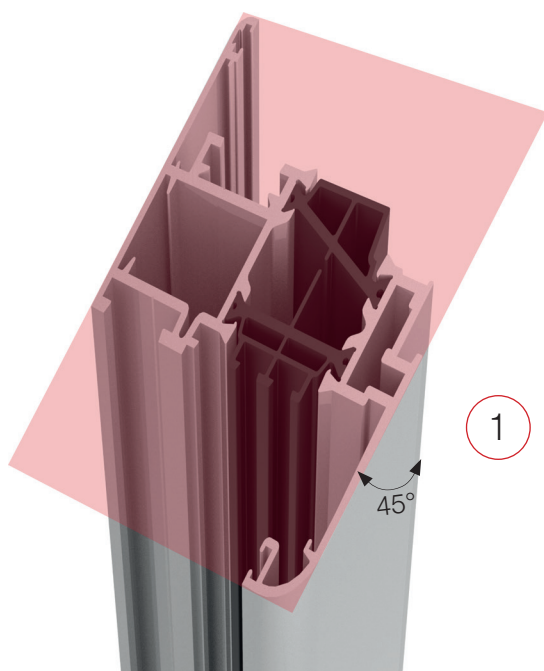

1 Tagliare a 45°  
il profilo TT 61812.

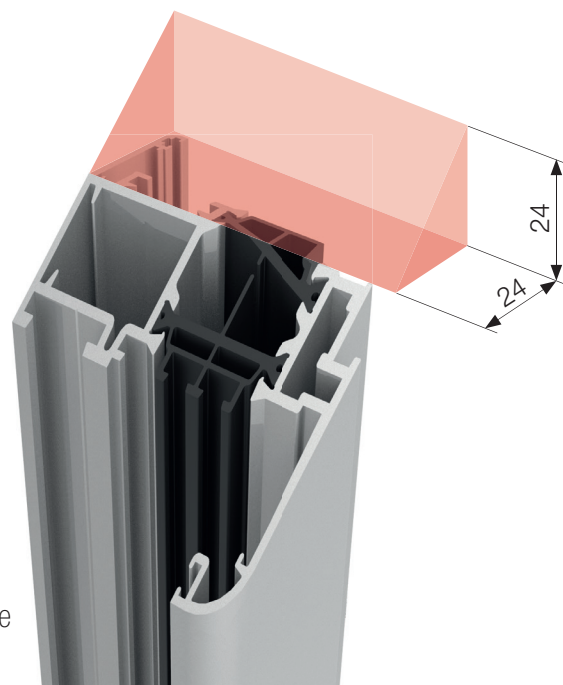

2 Spuntare il profilo, come  
indicato in figura.

EasyDoor
Elite Door 72
Door 62
Door 72
Sirio 50
Smart 30
Planet 45
Planet 50 TT
Planet 50 PLUS
Planet 62 TT
Planet 62 PLUS
Planet 72 HT
Planet 72 PLUS
3G
Fullglazing
Matic 50
Matic 50 PLUS
Matic 62 TT
Matic 62 PLUS
Matic 72
Matic 72 PLUS
Nathura 59
Nathura 70
Nathura 82
Nathura 92
Slide 60
Slide 65
Slide 80/106 PLUS
Topslide 160
Slidewood 160
Topslidewood 214
Panoramico
Balconi e balaustre



**Info prodotto 1902.1**  
26.03.2019

# SOLUZIONE T all'italiana

## Applicazione tappo ACP 50121M

### PLANET 62 PLUS

#### ATTENZIONE

Inserire il tappo prima di assemblare l'anta.

ACP 50121M

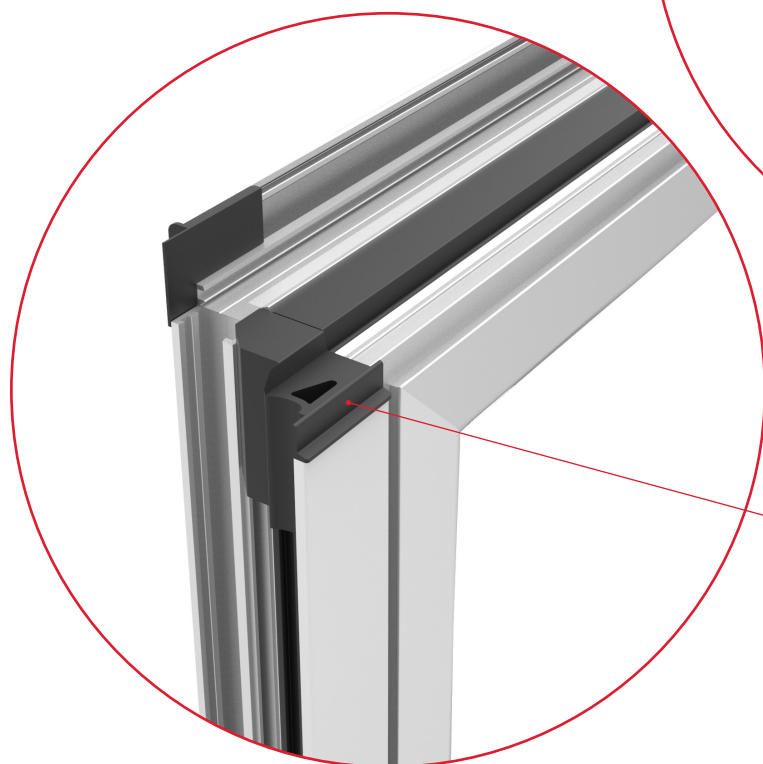
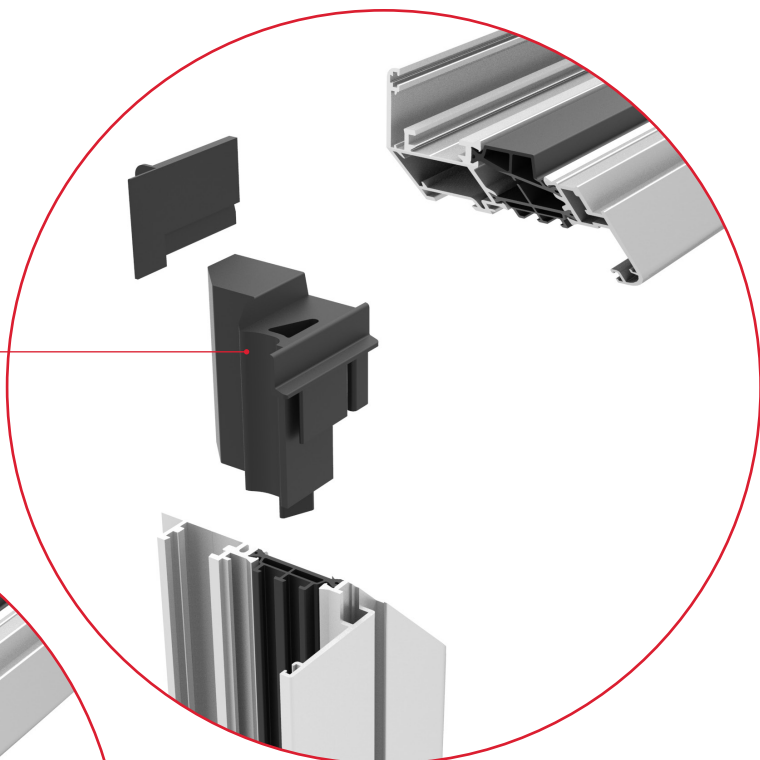

Prima di assemblare il tappo al profilo sigillare tutta la zona di contatto per evitare infiltrazioni, F-polymer AGP 5035/F.

EasyDoor	Elite Door 72	Door 62	Door 72	Sirio 50	Smart 30	Planet 45	Planet 50 TT	Planet 50 PLUS	Planet 62 TT	Planet 62 PLUS	Planet 72 HT	Planet 72 PLUS	3G	Fullglazing	Matic 50	Matic 50 PLUS	Matic 62 TT	Matic 62 PLUS	Matic 72	Matic 72 PLUS	Nathura 59	Nathura 70	Nathura 82	Nathura 92	Slide 60	Slide 65	Slide 80/106 PLUS	Topslide 160	Slidewood 160	Topslidewood 214	Panoramico	Balconi e balaustre			
										●				●																					

Info prodotto 1902.1

26.03.2019

## SOLUZIONE T all'italiana

### Applicazione tappo ACP 50121M

### FULLGLAZING

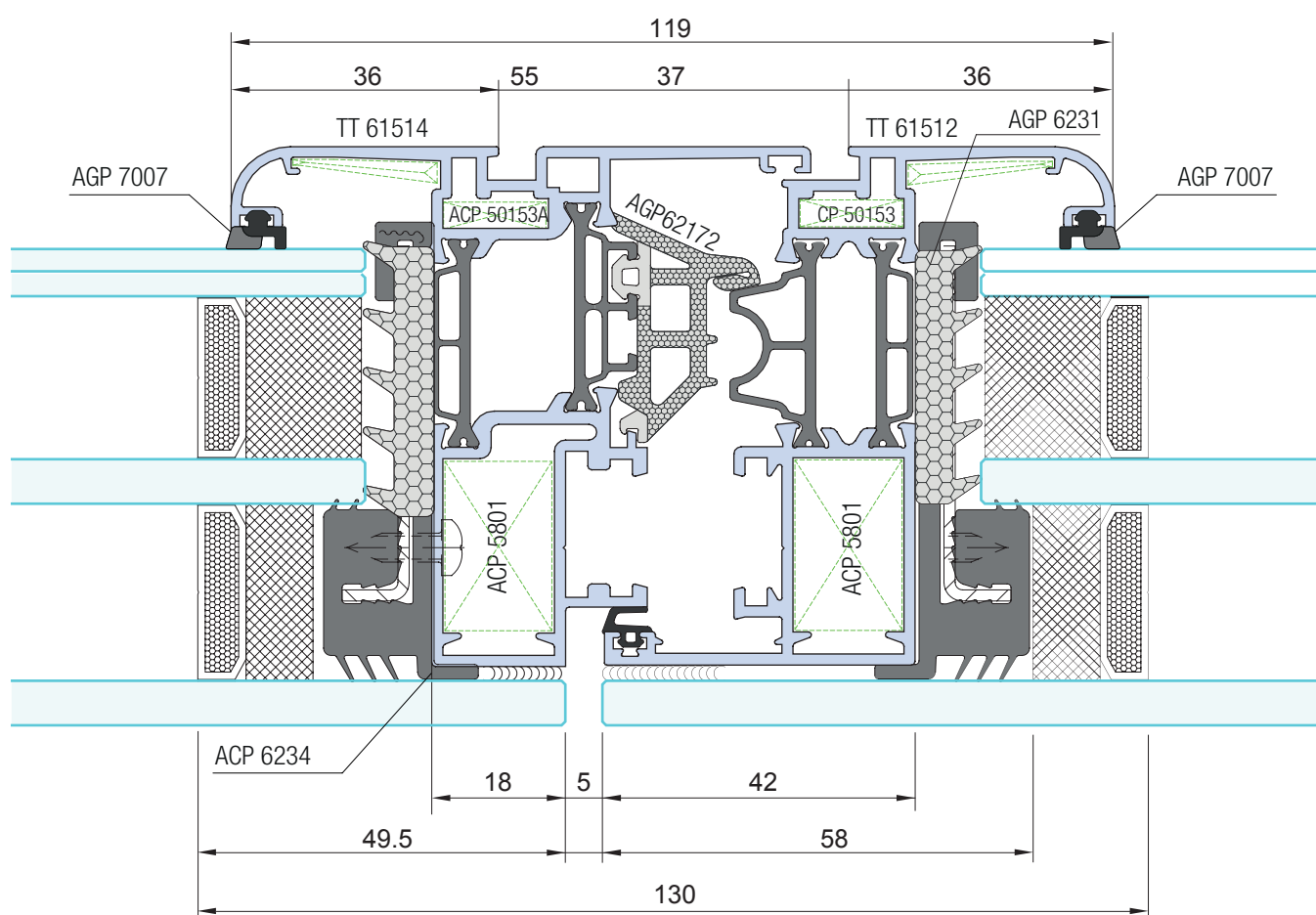

NODO CENTRALE - APERTURA INTERNA

EasyDoor	Elite Door 72	Door 62	Door 72	Sirio 50	Smart 30	Planet 45	Planet 50 TT	Planet 50 PLUS	Planet 62 TT	Planet 62 PLUS	Planet 72 HT	Planet 72 PLUS	3G	Fullglazing	Matic 50	Matic 50 PLUS	Matic 62 TT	Matic 62 PLUS	Matic 72	Matic 72 PLUS	Nathura 59	Nathura 70	Nathura 82	Nathura 92	Slide 60	Slide 65	Slide 80/106 PLUS	Topslide 160	Slidewood 160	Topslidewood 214	Panoramico	Balconi e balaustre	
										●				●																			

1  
Montaggio tappo centrale T all'italiana ACP 50121M

Application of glass support ACP 6234

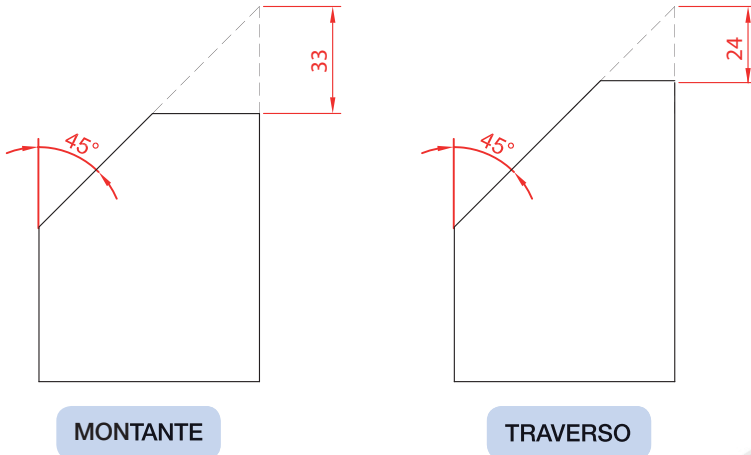

ACP 50121M



MONTANTE

TRAVERSO

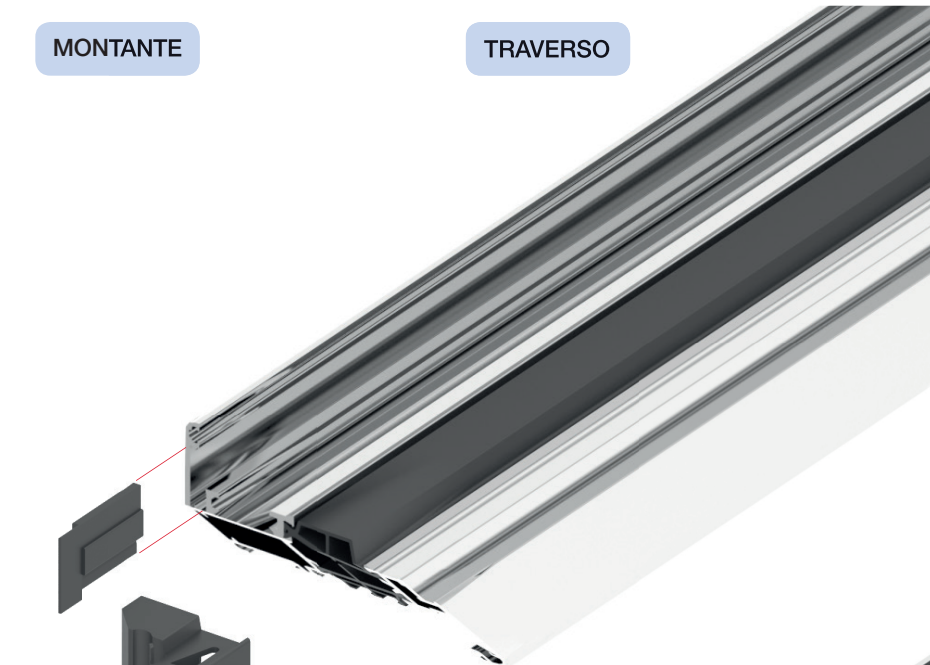

Dopo aver spuntato il montante come indicato in sezione (vedi sopra) eseguire fresata 9x4,5mm  
After cutting mullion milled as shown in the figure, 9x4,5mm



Prima di montare il tappo riporto occorre sigillare le zone evidenziate nel disegno  
Before installing astragal cap, seal areas shown on drawing

Riporto centrale  
T all'italiana

