

GENERAL CONTENTS

technical description for specifications	1
suggestions for installation	7
cleaning and maintenance of frames	7
anodising and painting	8
advice for assembly	9
accessory certifications	10
Planet 62 TT certifications	11
door and window symbols	15
limit curves for use	16
profile outlines	18
1:1 scale profiles	28
glazing	59
gaskets	63
accessories	66
cutting lists	77
nodes and sections	89
equipment	131
machining	132
cutter units	143
accessory assembly sheets	156

PRINTED IN ITALY ON 30 JULY 2010

PLANET 62 TT SPECIFICATIONS

General specifications for the supply and installation of frames produced within the range of European chamber Planet 62 TT thermal break doors and windows.

Materials

The doors and windows are made from aluminium alloy EN AW 6060 extruded profiles as indicated in standard EN 755.3.

The supply condition is within class T5 and T6 in accordance with standard EN 755.2. Dimensional tolerances comply with UNI 12020-2 : 2001.

Technical and dimensional characteristics

External visual appearance: flush

Internal visual appearance: flush or overlapping 8mm

Profiles: light alloy 6060 (UNI35690TA) extrusions; they can be anodised and painted

Sealing system: open joint with pre-chamber or double rebate, with EPDM gaskets

Thermal insulation system: made using 28mm polyamide tubular spacers

Accessory system: top quality European chamber

Distance between frame and leaf: 11.5mm

Superimposition of leaf rebate on frame: 6mm

Height of glass rebate: 22mm

Space between the profiles: 5mm

Frame depth: 62mm/70mm

Leaf depth: 69mm/70mm

Tubularity of window profiles: 15mm

Tubularity of door profiles: 36.4mm

Glass fastening: with smooth or radial glazing beads

Space for glass or panel in fixed frames: from 27mm to 55mm

Space for glass or panel in leaves: from 27mm to 63mm

Surface protection

The profiles can be protected by means of anodic oxidation with thickness category >15 micron as per standard UNI 4522/00 (66-70), or by painting with thermosetting polyester in powder form and oven polymerised in accordance with the "Qualicoat" quality procedures and with standard UNI EN 12206-1

Resistance of the finish

The surface finish must not suffer any corrosion or alterations in appearance for a period of time appropriate to the life of the product. The characteristics required to ensure the behaviour in accordance with the type of environment are specified in standards UNI4522/00 for oxidation and UNI EN 12206-1 for painting, bearing in mind that the key factors influencing weather resistance are proximity to the sea, atmospheric pollution, maintenance and cleaning also from rain.

Safety

In order to prevent physical harm or injury to users, the doors and windows must be designed in accordance with the relevant safety legislation, Italian Leg. Decree 81/2008 and UNI 7697-07.

Characteristics of the glazing

The glazing must be selected in accordance with performance criteria to meet the requirements of energy saving, sound insulation, solar radiation control, safety. Relevant standards: UNI EN ISO 140-3:06, UNI6534:74, UNI EN 572-1:04, UNI EN 12758:04, UNI EN 12150-1:01, UNI 7143:72 DM 2 April 1998.

Gaskets

The gaskets must only be the originals designed for the system, guaranteeing its performance and complying with reference standards UNI 3952:98, UNI 12365:05.

Sealants

The sealants must comply with the provisions of reference standards UNI EN ISO 11600:04. These materials must not corrode the parts made of aluminium and its alloys with which they come into contact and must therefore be non-acetic or MS-polymer based.

Accessories

The accessories must be the original ones produced for the range and in accordance with the criteria indicated in UNI standards and with the safety legislation, Italian Leg. Decree 81/2008.

Performance

The Planet 62 TT range meets the requirements of standards UNI EN 12207:00, UNI EN 12208:00, UNI EN 12210:00.

Mechanical resistance

The system and its accessories shall be resistant to the stress of use in accordance with the limits established in standard UNI 12365:05.

Sound insulation

The choice of the type of sound insulation for a door or window depends on the intended purpose of the location in which the frame is to be fitted and on the level of external noise; the behaviour of the door or window on site is influenced by factors that cannot be determined beforehand (height from the floor, orientation of noise sources, etc.). The sound insulation capacity can therefore be estimated to a large degree, based on window/door air permeability, with a minimum permeability value of 2, and on the sound insulation capacity of the glass. In accordance with the methodology described in reference standard UNI EN ISO 140-3:06.

Thermal insulation

The choice of the heat insulation properties must be made on the basis of the energy saving requirements in accordance with law 10/91 and L.D.192/05 and

update L.D.311/06 and of the environmental wellbeing requirements or with reference to standard UNI EN ISO 10077-1:07. The window/door thermal transmittance can be calculated from the transmittance values of the profiles and of the surfaces in accordance with standard UNI EN ISO 10077-1:07 using the formula:

$$U_w = (A_g \cdot U_g + A_f \cdot U_f + I_g \cdot \psi) \div (A_g + A_f)$$

Certifications

It is possible to ask the manufacturer of the windows/doors, or alternatively the local licensee, for a photocopy of the test reports relating to specific properties.

CE Marking UNI EN 14351-1

CE marking is **OBLIGATORY** and is the system to which all manufacturers of doors and windows must comply in order to be able to sell their products in the European Union. The Manufacturer, or its representative, with its headquarters in the EEA [European Economic Area] is responsible for affixing the CE marking to its product, on a label applied to the product, on its packaging or on its accompanying commercial documents.

Standard UNI EN 14351-1 applies to windows, glass doors, external pedestrian doors, external doors on escape routes, roof windows/skylights (including those resistant to external fire), ribbon windows, coupled windows and double windows. These doors/windows can have one or more leaves, with moving leaves and fixed parts, opening inwards or outwards, operated manually or automatically, completely or partially glazed, with or without a frame to contain the glass, with or without built-in shielding devices.

Standard UNI EN 14351-1 does not apply to:

- windows, glass doors and pedestrian doors with fire-resistant and smoke-proof characteristics
- internal doors (EN 14351-2)
- external obscuring shutters (UNI EN 13659)
- revolving doors
- windows situated on escape routes

The standard relates to certain voluntary and/or obligatory requirements:

- Watertightness
- Release of hazardous substances
- Impact resistance
- Wind resistance
- Load-bearing capacity of safety devices
- Sound insulation
- Thermal insulation
- Glass radiance (light transmission)
- Air permeability

Factory Production Control (FPC)

Factory production control is a system implemented by the manufacturer under its own responsibility, in order to ensure that the structural characteristics of the product are maintained over time within certain limits. The manufacturer must establish certain documented procedures, which indicate the methods that the personnel responsible for various controls must implement in order to monitor the process assigned to them frequently and accurately. The manufacturer is obliged to guarantee the traceability of the product by using codes or other methods. By means of a diagram, the manufacturer is also obliged to inform the purchaser of instructions relating to the use, handling, installation, maintenance and cleaning of the product. The installation characteristics, however, are not analysed.

Laboratory Test (ITT)

The characteristics of the door/window are assessed on the finished product complete with its metal fittings, double glazing, panels and all the accessories and treatments that render it ready for use. Any manufacturer who requests it can obtain the results of the tests (ITT) on the doors/windows directly from Al sistem or from the local licensee, which grants the right to use the results of the certificates of the ITTs received from the Laboratory, by means of a cascading agreement between the parties. The manufacturer is responsible for the product's compliance with the European standards indicated in the draft standard and found in the national standards (UNI standards).

General specifications

Aluminium frames with European-type chamber accessories (standardised chamber) created with the range for Planet 62 TT thermal break doors and windows with open-joint seal. The profiles are extruded in aluminium alloy EN AW 6060 (EN 573.3), supply condition T5 and T6 in accordance with standard EN 755.2 with dimensional tolerances and thicknesses compliant with standard UNI EN 755-9 and UNI12020-2 : 2001. The thermal insulation will consist of 28 mm polyamide 6.6 bars reinforced 25% with fibreglass with a moisture absorption value lower than 2% at a temperature of 23°C and a level of humidity at 50%; the bars are assembled by means of computerised mechanical rolling, and the mechanical characteristics of the bars must remain unaltered up to a maximum treatment temperature of 245°C.

The production process is controlled in accordance with UAETC standards, the sliding values must be greater than 24 daN/mm. The fixed frame shall be 62mm deep, whilst the openable parts shall be 70mm deep. The sealing system shall be of the open joint type with a central EPDM gasket with a seal fin on the sloping surface of the profile on the moving part of the window; the central gasket must be connected at the corners with the appropriate vulcanised corners. The profiles have been designed with rounded lines internally and externally with the possibility of accommodating glazing bead solutions cut at 45° or 90°; where cut at 90° with rounded glazing beads, the appropriate connecting corners in die-cast aluminium can be used. The glazing must be sealed in accordance with the instructions shown in the catalogue and solely and exclusively with original glazing bead gaskets. Appropriate drainage holes must be provided on the fixed frame and on the moving frame in order to allow the correct drainage for the window/door. The limits of use

of the profiles depend on their geometric characteristics, on the scope of the accessories and on the operating loads. The accessories used in the manufacture of the various types must be solely and exclusively the originals designed especially for the system, as shown in the catalogue and distributed by the AL sistem licensees; the use of products other than those indicated or their partial or incorrect assembly shall render the test certificates and guarantee null and void. The manufacture and installation must be in accordance with the operating criteria indicated by AL sistem. The profiles shall be assembled with brackets in extruded or die-cast aluminium to be buttoned, pinned, crimped or screwed, the edges must be protected with acrylic, silicone or MS polymer sealants.

The profiles must be protected and finished by means of normal surface treatments, anodic oxidation compliant with the "Qualanod" quality label or by painting with thermosetting polyester in powder form and oven-polymerised at temperatures between 185°C and 195°C, in accordance with the "Qualicoat" quality label.

Thermal counter-frame: general specifications

L-shaped counter-frame for the installation of doors and windows, the internal part consisting of galvanised steel including cramps for securing it to the wall and the external part in recycled PVC or ABS.

The counter-frame is installed like any normal counter-frame on 3 sides, 2 vertical and one horizontal above, acts as a template for laying the internal plaster, the special shape ensures a perfect finish, the external PVC part has a fin that also acts as a template for the external plaster, the particularly rough surface combined with the mesh for the plaster will prevent any cracks or leakages or any air from infiltrating.

The external PVC part acts as a thermal break, thus preventing the high performance provided by the Planet frame from being compromised.

The frame will then be mounted on the counter-frame using screws through special slanted wall guides which prevent any breakage of the plaster due to their particular sloping fixture, the window frame will be equipped with perimeter sealing to guarantee a perfect hermetic sealing of the counter-frame/frame combination, finally, the residual space between external fin and aluminium frame will be filled with regulation sealant.

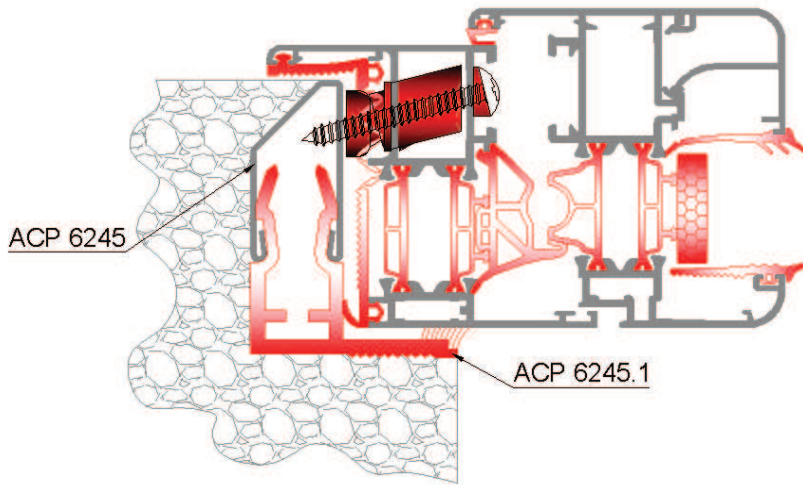

THERMAL COUNTER-FRAME APPLICATION, TYPICAL SECTION

FLOW OF ISOTHERMS USING GALVANISED STEEL COUNTER-FRAME

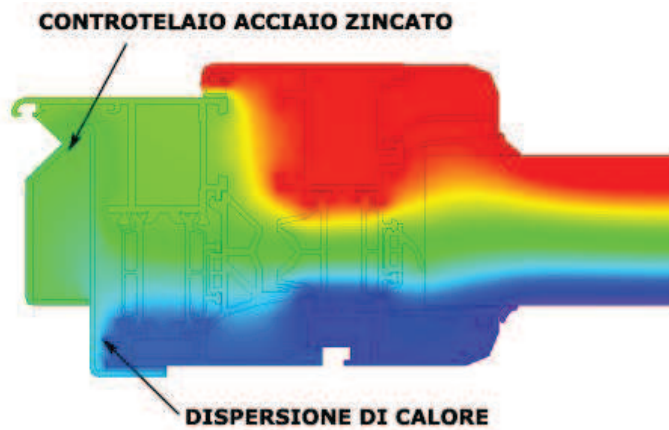

FLOW OF ISOTHERMS USING THERMAL BREAK COUNTER-FRAME

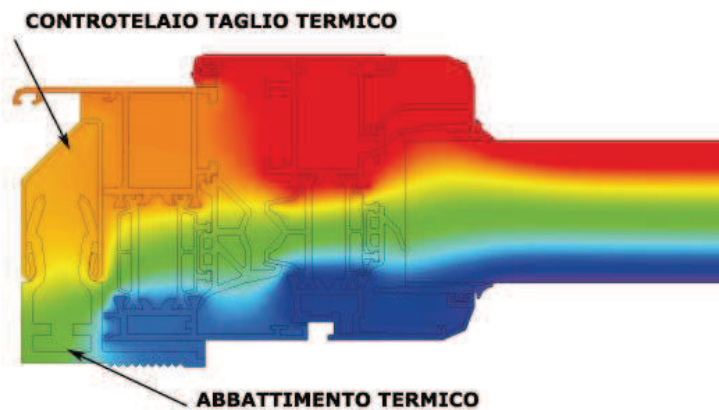

Installation

In order for the window to operate properly, it is very important to pay extremely close attention to the vertical positioning and levelling of the frame, and then to seal it using neutral adhesive, following the advice in the example shown below, also checking that the openings are sufficiently filled (shimming the glass 1-2 mm out of square), so that, with the adjustment of the materials, there is no deterioration of operation over time.

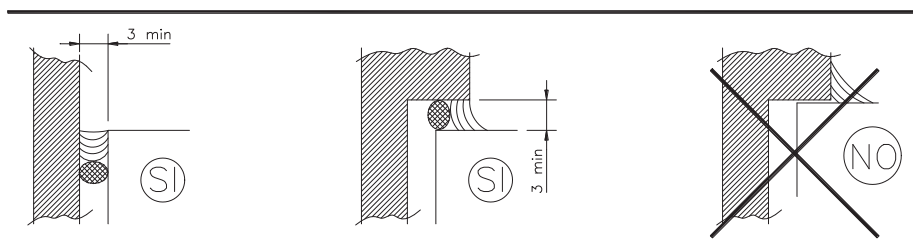

Maintenance of the aluminium surfaces

In view of the high amounts of pollution now reached in all countries, particularly in large cities and in coastal areas beaten by the sea wind, it is very important for aluminium surfaces that are in contact with the atmosphere to be cleaned regularly. Our intention is to raise the awareness of the manufacturers of doors and windows so that they can in turn advise THE CLIENT as well as possible.

It is good practice to take 3 fundamental points into consideration:

- 1- how often the cleaning operation must be carried out over the course of the year
- 2- the period
- 3- the product to be used

Here are the answers:

The number of cleaning operations depends on the level of pollution in the area in which the building is located, ranging from 1 to 3 times a year.

The period may be:

- at the end of winter
- in the middle of summer
- in the middle of autumn, depending on the number of cleaning operations

It is important that the product to be used for cleaning is neutral; using the wrong product could ruin the various different materials of which a door or window consists (gaskets, sealants, marble, etc) and cause damage that could compromise the efficiency and life of the product.

The characteristics of these products as well as the frequency of the cleaning to be adopted are defined in draft standards UNIMET12.04.270 and E12.04.277.0.

If no neutral product is available, it is preferable to use warm water with a non-abrasive cloth.

In order to install, maintain and clean the doors and windows correctly, we also suggest that you consult the instructions contained in the following Uncsaal technical notes:

UX 42 guide to installing windows

UX 10 cleaning of surfaces of doors/windows and continuous facades

Painting phases

1. The painting cycle offer the possibility of obtaining an excellent protective coating on the surface of the frames and a greater brightness of colour;
2. The layer must have a min. thickness of 60 micron on the visible parts;
3. the material shall be subjected to the following process:
 - removal of grease/dirt without etching
 - washing
 - alkaline pickling with etching
 - washing
 - deoxidising
 - washing
 - chromate treatment
 - washing in demineralised water
 - drying at 75°C
 - painting in thermosetting powder coating
 - oven polymerisation

All operations carried out on aluminium must comply with the provisions of the "Qualicoat" quality label.

Anodisation phases

1. The oxide layer may vary from 15 to 20 micron (UNI4522-66), according to the area in which the door/window is located;
2. it can be normal or electro-colour;
3. the material shall be subjected to the following process:
 - removal of grease/dirt without etching
 - washing
 - alkaline pickling with etching (except for shiny finishes)
 - washing
 - deoxidising
 - washing
 - oxidation in sulphuric acid bath at 18/20°C, density of corrosion 1.5[A]dmq
 - inorganic or organic colouring or electro-colour (except for silver)
 - double washing
 - drying
 - hot fixing boiling with nickel salts, fixing 2.5/3 minutes for every micron of thickness

Observation

During the preliminary phase the project manager or door/window fitter must determine the type of door/window to be used depending on the elements provided by the client. During the selection or inspection, the necessary moment of inertia must be considered depending on the wind pressure and the required profile chosen from the Planet range. Obviously, the appropriate accessories must be used from the original AL sistem accessories, provided for the Planet range.

Profile dimensions and weights

The dimensions and weights indicated on the drawings of the profiles in the catalogue are theoretical and can vary according to the extrusion dimensional tolerances (Standard UNI EN 12020-02) and to the type of finish. Painting also adds to the thickness, thus reducing the housings for inserting the gaskets and accessories. This variability could influence the dimensions of the cut and consequently those of the finished door/window. The differences in cut can increase also in proportion to the number of leaves per door/window. It is advisable, in initial works or in those with large quantities, to create a true sample to check that it works properly.

Cut dimensions

The theoretical dimensions of cut indicated in this catalogue must be altered according to the type and depending on the precision of the cutting machine being used, (e.g. for double-leaf doors opening outwards with panic exit bar, the space must be 8 mm rather than 5 mm etc.).

Advice for correct assembly

To obtain the best results when using Planet profiles, it is advisable to pay careful attention to all of the following points, designed to reinforce all of the weak points of a normal window, thus optimising the performance offered by the window.

Correct procedure	Objective
seal the profiles together in the join at 45°	prevents water seepage, prevents corrosion and oxidation
seal the profiles on the jamb when they are faced	prevents water seepage, prevents corrosion and oxidation
use the open joint gasket on the sill also in the double rebate solution	facilitates water drainage
use the vulcanised corner of the central rebate gasket	increases air permeability increases watertightness
use limit curves to select the profile	avoids choosing the wrong profile
seal the window or door on the perimeter between profile and counter-frame with neutral sealant	prevents water seepage
always use the wall spacer	facilitates installation, ensures better frame positioning, insulates materials, minimises the transmission of vibrations
protect all the work carried out on the profiles	prevents corrosion and oxidation increasing the life of the frame over time
for installations with emergency openings use oversized profiles	facilitates the application of accessories
use counterprofile during the 45° cut	guarantees a correct cut in order to obtain a perfect angle joint
use multi-purpose corner brackets	guarantees high-quality joints

Accessory certification



The combined leaf is certified with the RAL label



The painted aluminium products are certified according to the technical specifications of:

QUALICOAT



The anodised aluminium products are certified according to the technical specifications of:

EURAS
EWAA
QUALANOD



The accessories for the Planet ranges are produced by ISO9001 and ISO14001 certified companies

Important

All the information provided in this catalogue is for guidance purposes only and in no way commits the company, which reserves the right to make improvements to its products whenever it deems this to be necessary. The company reserves the right of ownership of this catalogue and it is prohibited to reproduce or transfer it to third parties without written authorisation.

PLANET 62 TT range certifications

The Planet 62 TT system has been subjected to the tests shown in the table for the different types of door and window.

TYPES OF DOOR AND WINDOW							
	Low sill, 2-leaf, open-out door with panic exit bar		H = 2,400 mm W = 1,500 mm	0970-CPD-RP0846	class 4	class 1A	class C4
	Low sill 2-leaf open-in door		H = 2,400 mm W = 1,500 mm	0970-CPD-RP0845	class 4	class 1A	class C4
	Low sill 2-leaf open-out door		H = 2,400 mm W = 1,500 mm	0970-CPD-RP0844	class 4	class 1A	class C4
	1-leaf tilt window		H = 1,650 mm W = 1,500 mm	0970-CPD-RP0760	class 4	class E1200	class C5
	4-leaf window		H = 1,650 mm W = 3,000 mm	0970-CPD-RP0735	class 4	class E750	class C4
	Parallel sliding		H = 2,400 mm W = 1,500 mm	1994-CPD-RP0166	class 4	class E1500	class B4
	Horizontal and vertical pivot		H = 2,000 mm W = 2,000 mm	1994-CPD-RP0167	class 4	class E900	class C4
	2-leaf tilt glass door		H = 2,400 mm W = 1,500 mm	1994-CPD-RP0164	class 4	class E750	class B4
	2-leaf tilt window		H = 1,650 mm W = 1,350 mm	0970-CPD-RP0240	class 4	class E1050	class C5
	TESTS						
	Door/window w size						
	Certificate number						
	Air permeability test value						
	Watertightness test value						
	Wind resistance test value						

TEST	DOOR/WINDO W TYPE	DOOR/WINDO W SIZE	CERTIFICATE NO.	DOUBLE GLAZING	RESULT
Sound test value	2-leaf tilt window	H =1,650 mm W =1,350 mm	4633-RP-08	88.2A/15/44.2A, 50 dB Rw	dB = 45 dB
Sound test value	2-leaf tilt window	H =1,650 mm W =1,350 mm	4632-RP-08	44.2A/15/44.2A, 44 dB Rw	dB = 44 dB

Determining the thermal transmittance of the nodes in the Planet 62TT system for doors and windows

In order to determine the thermal transmittance of the profiles, the entire Planet 62TT range has been certified, by the notified laboratory IRCCOS in Legnano, in accordance with product standard EN 14351-2006, following the parametric line method. The reference code of the document issued by the laboratory corresponds to no. RT/017/2010.

Methodology of analysis used

For the range in question a limited number of samples were analysed, representing a part of the whole range. From careful analysis of the morphology of the identified sections, the nodes showing homogenous characteristics were divided into various groups, as listed below:

- fixed lateral nodes
- openable lateral nodes with glazing bead
- openable lateral nodes, without glazing bead
- openable central nodes, with glazing bead
- openable central nodes, without glazing bead
- nodes for crosspiece
- openable lower nodes
- fixed lower nodes
- open-out lateral nodes
- open-out central nodes
- double-rebate nodes
- nodes for pivot
- nodes for industrial sheds
- nodes for single units
- nodes for pillars
- nodes for angles.

Subsequently, for each group, a series of linear interpolation lines were constructed to give the U_f value of the nodes according to the b_t/B values assumed as variables, where:

- b_t = sum of the width of the thermal break present in the section, of each profile
- B = total width of the section.

In the case of particular couplings, and usually singles, where it is not possible to obtain correlations based on the above principles, the calculation was made for the single sections. The thermal transmittance was calculated in accordance with standard UNI EN ISO 10077-2;2004. The calculations were made using a 24 mm thick panel in place of the glazing. The "Flixo 6.0" software was used for the calculations. The choice of the materials in table A.1 of standard UNI EN ISO 10077-2:2004, as well as in the case of materials not appearing in the table, was made on the basis of the documentation supplied by AL sistem.

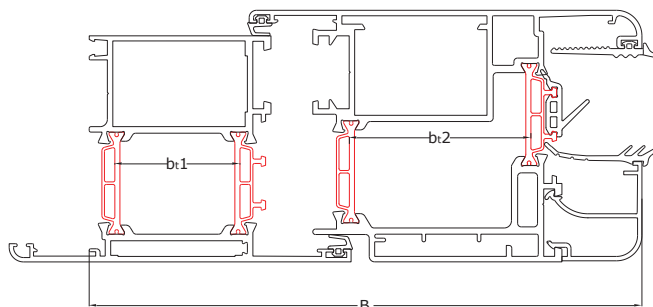

Shown below, as an example, is a page of the document representing the openable lateral nodes with glazing bead:

Openable lateral nodes with glazing bead

Line no. or Uf value	Node codes	Representative Node
Line 4	6103+6112 6133+6117	
Line 5	6102+6112 6132+6117	
Line 6	6101+6112 6131+6117	

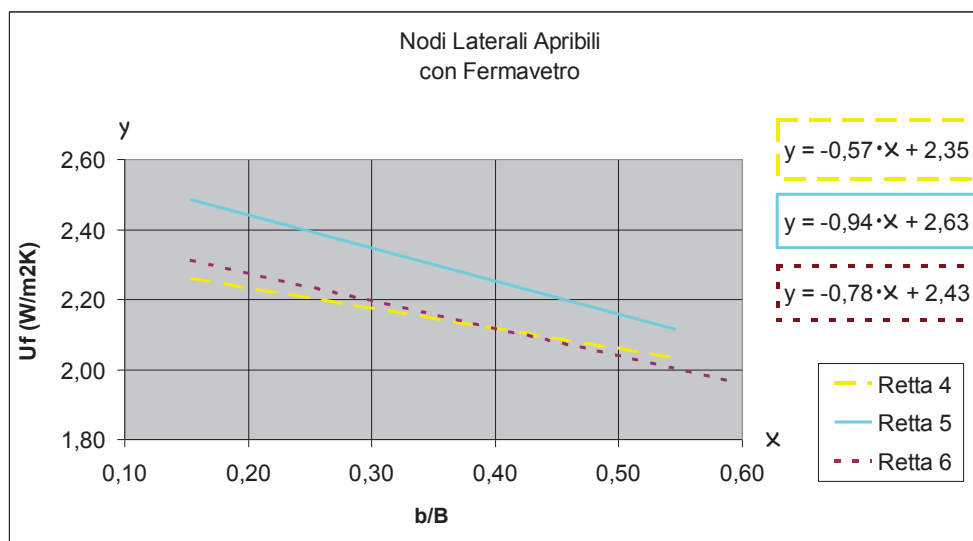

To obtain the Uf values

Example:

in the case of the node consisting of profiles TT6103+TT6112, in accordance with line 4, the calculation will be as follows

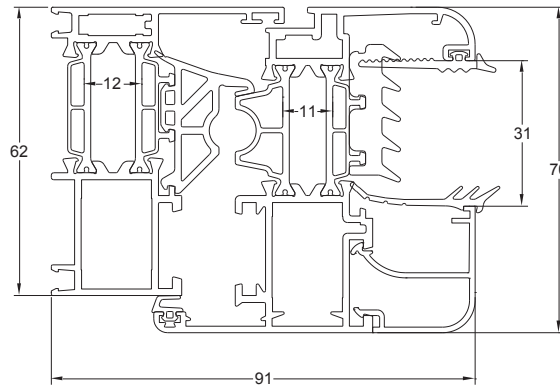

$b_t = b_1 + b_2 = 11\text{mm} + 12\text{mm} = 23\text{ mm}$
 $B = 91\text{mm}$
 $b_t/B = 23\text{mm}/91\text{mm} = 0.25\text{mm}$
 $X = 0.25\text{mm}$

BY MEANS OF FORMULA

$Y = -0.57 \cdot X + 2.35 = -0.57 \cdot 0.25\text{mm} + 2.35 = 2.20$

BY MEANS OF DIAGRAM

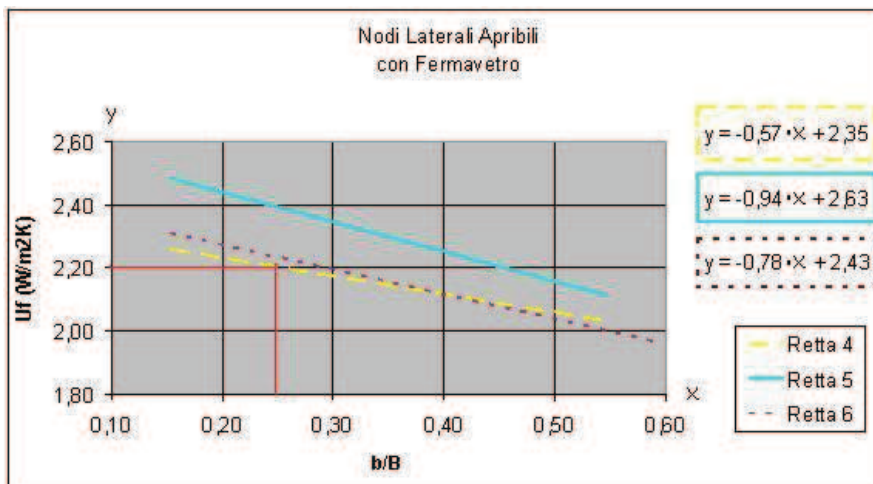

THE RED LINES INDICATE THE TRANSPOSITIONS OF VALUES X AND Y

N.B: for more detailed information, see notified document RT/017/2010 of the IRcCOS laboratory in Legnano, on request from AL sistem.

It must also be noted that certain actual values already present in the calculation software Termosoftware and FP-PRO may not coincide with what is obtained from the formulae or from the diagrams shown in the document; this is due to the fact that the lines obtained are the result of the average of the actual individual values.

The actual values of the nodes present in Termosoftware and FP-PRO can however be used, whilst those missing can be obtained by using the formulae or the lines within the document, which will be different for every AL sistem range of system.

door and window symbols (internal view)

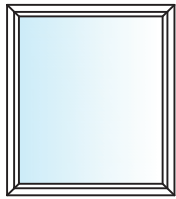

fixed

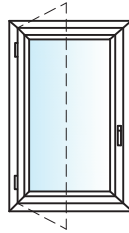

1 leaf

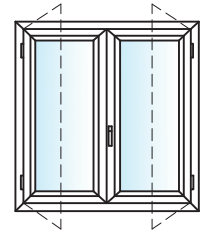

2 leaves

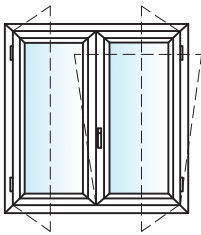

tilt leaf

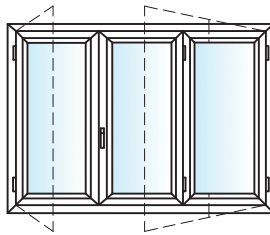

3 leaves

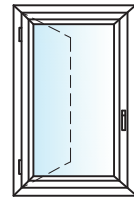

opening outwards

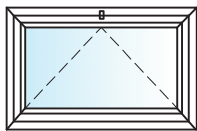

vasistas

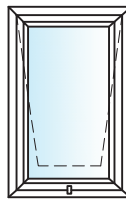

top-hinged

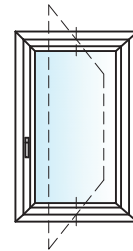

vertical pivot

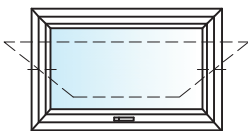

horizontal pivot

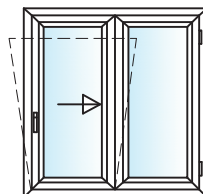

parallel sliding

it is not recommended to produce windows with leaves of a width less than $W=500$ mm

limit curves for use

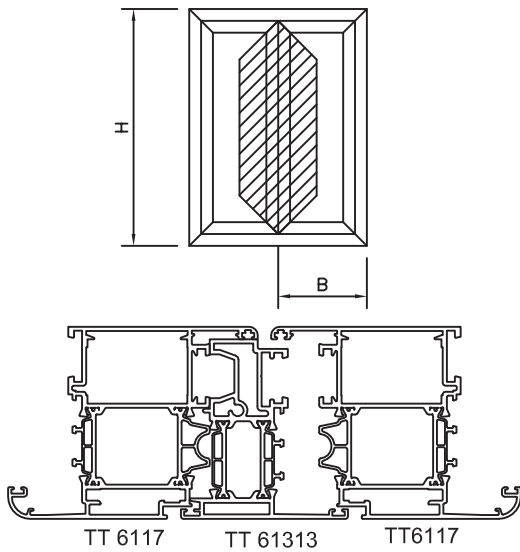

$Jt = 110.26 \text{ cm}^4$
max deflection 1/300

CHECK THAT THE DEFLECTION OF THE PROFILE IS COMPATIBLE WITH THE GLASS USED

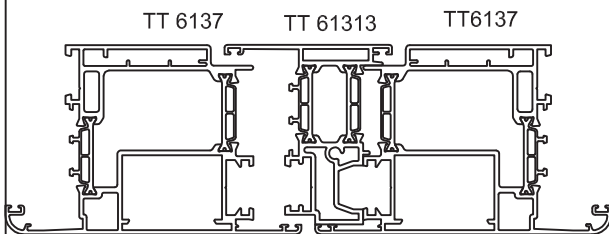
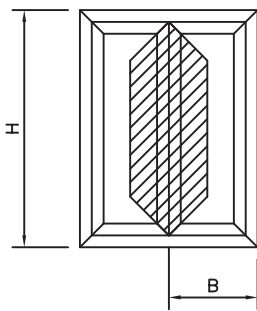
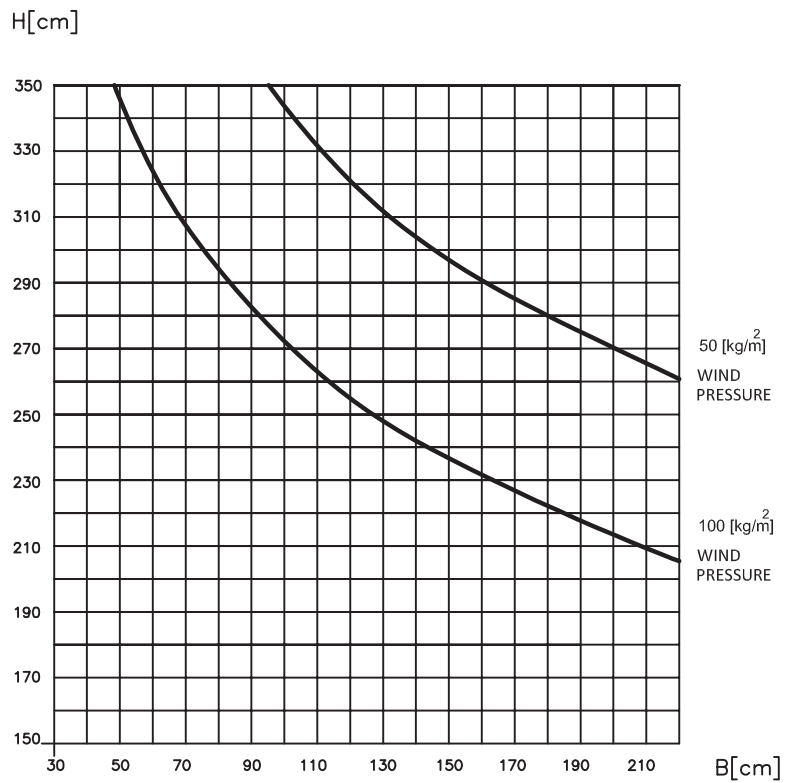

$Jt = 133.37 \text{ cm}^4$
max deflection 1/300

CHECK THAT THE DEFLECTION OF THE PROFILE IS COMPATIBLE WITH THE GLASS USED

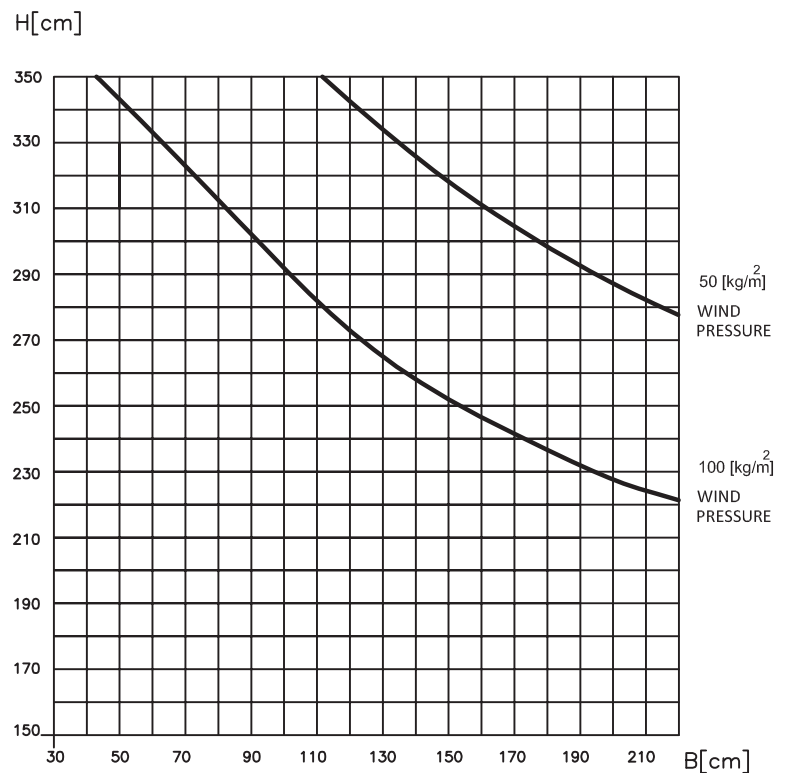

limit curves for use

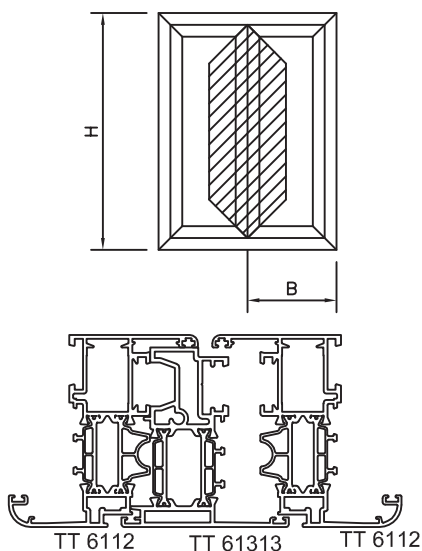

$J_t = 88.99 \text{ cm}^4$

max deflection 1/300

CHECK THAT THE DEFLECTION OF THE PROFILE IS COMPATIBLE WITH THE GLASS USED

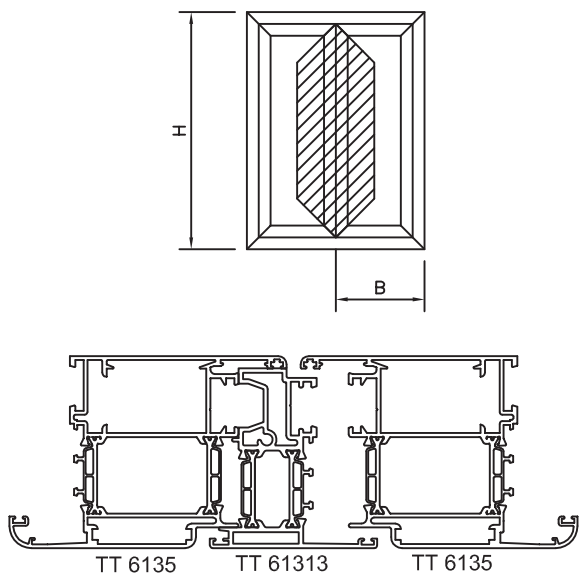
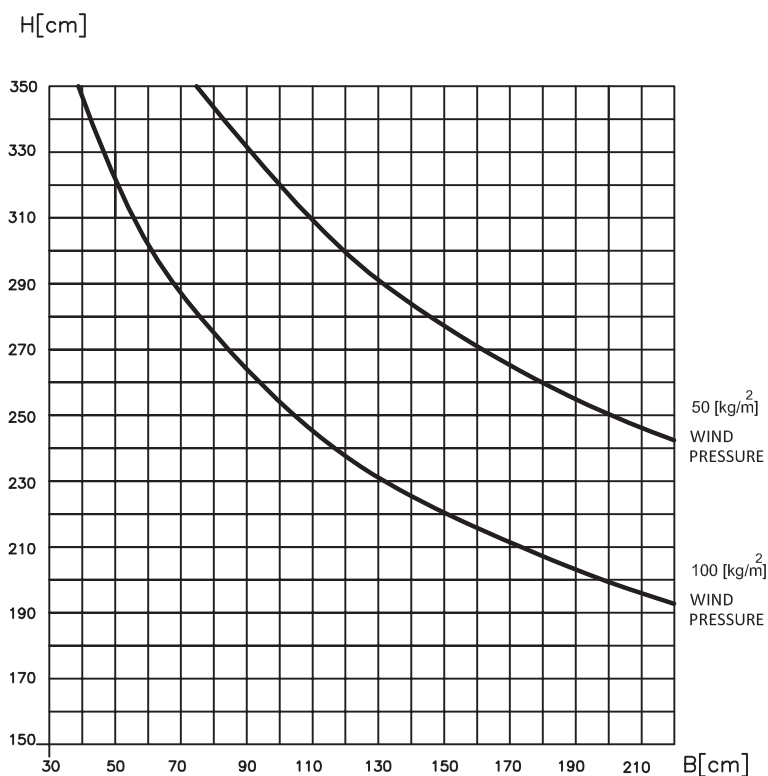







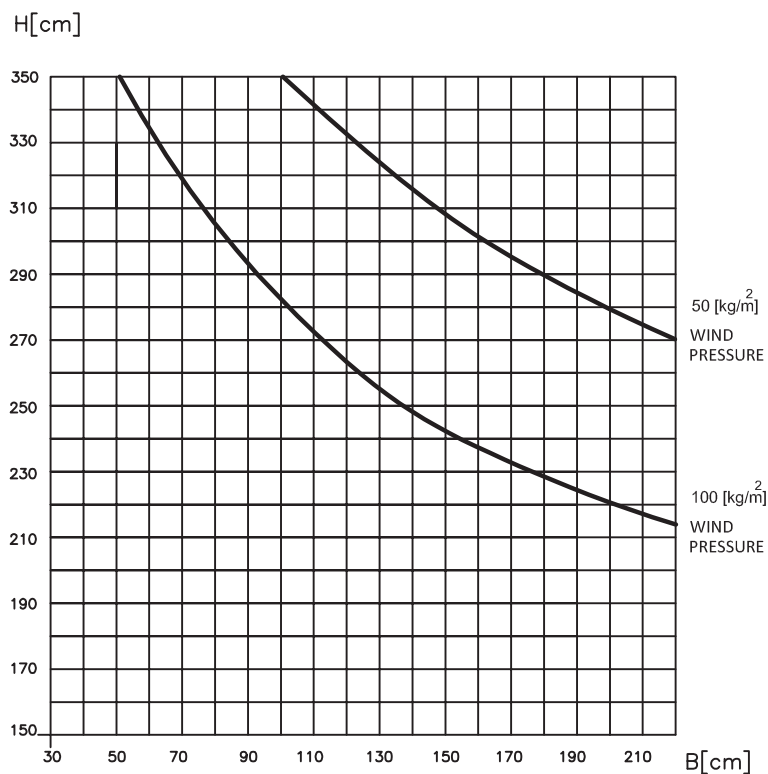

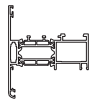
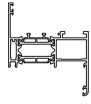
$J_t = 121.53 \text{ cm}^4$

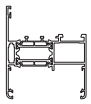
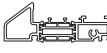
max deflection 1/300

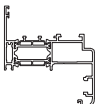
CHECK THAT THE DEFLECTION OF THE PROFILE IS COMPATIBLE WITH THE GLASS USED

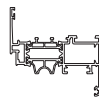
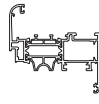
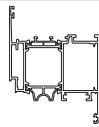
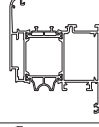
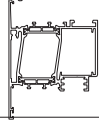

ITEM	OUTLINE	DESCRIPTION	WT. gr/m	Jxx cm ⁴ Jyy cm ⁴
TT 6101		FIXED T FRAME	1270	21.90 8.56
TT 6102		FIXED Z FRAME	1261	23.95 8.41
TT 6103		FIXED L FRAME	1153	19.69 5.61
TT 6104		FIXED FRAME WINDOW LOWER CROSSPIECE	1378	26.60 11.00
TT 6106		30mm SILL	1307	31.58 2.86
TT 6107		25mm LOW SILL	754	12.51 0.76
TT 6108		FIXED Z FRAME – FLUSH 30mm REBATE	1473	36.13 15.00
TT 6109		FIXED L FRAME – FLUSH	1218	24.68 5.49
TT 6111		SMOOTH LEAF	1403	31.25 8.60
TT 6112		ROUNDED LEAF	1445	38.85 10.30
TT 6116		OVERSIZED SMOOTH LEAF	1847	41.90 29.40
TT 6117		OVERSIZED ROUNDED LEAF	1891	42.60 32.20
TT 6119		PIVOT LEAF	2008	41.68 38.01
TT 6120		PIVOT REBATE REVERSAL	1334	25.54 8.87







*it is advisable to use a counterprofile when cutting at 45°

ITEM	OUTLINE	DESCRIPTION	WT. gr/m	Jxx cm ⁴ Jyy cm ⁴
TT 6121		FIXED Z FRAME 30mm FIN	1302	25.85 10.78
TT 6122		FIXED Z FRAME 40mm FIN	1353	26.86 14.44
TT 6124		FIXED Z FRAME 70mm FIN	1527	18.80 34.25
TT 6125		73 mm SECTION LEAF	1496	34.82 10.88
TT 6128		72mm CROSSPIECE – FOR FIXED DOORS/WINDOWS, FIXING WITH CLAMP	1278	22.50 8.40
TT 6129		FRAME FOR COMBINING WITH PLANET SLIDE PROFILE RANGE, SECTION 80 mm	1319	29.00 5.84
TT 6130		FRAME FOR COMBINING WITH PLANET SLIDE PROFILE RANGE, SECTION 106 mm	1544	51.84 6.39
TT 6131		OVERSIZED FIXED T FRAME	1664	29.78 27.76
TT 6132		OVERSIZED FIXED Z FRAME	1655	31.85 27.48
TT 6133		OVERSIZED FIXED L FRAME	1547	27.57 21.99
TT 6134		Z FRAME, SECTION 65 mm	1376	29.80 11.79
TT 6135		OVERSIZED LEAF DOUBLE REBATE VERSION	2185	47.90 46.06
TT 6136 *		LEAF FOR TOP-HINGED SYSTEM	2025	42.41 24.34
TT 6137 *		OVERSIZED OPEN-OUT LEAF	2411	54.72 60.73



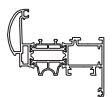
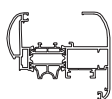
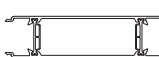
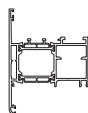
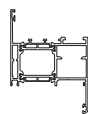
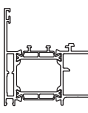

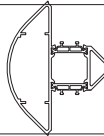

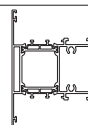

*it is advisable to use a counterprofile when cutting at 45°

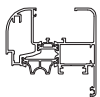
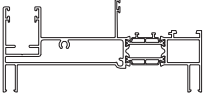
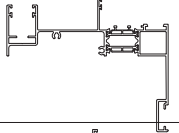
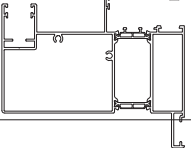
ITEM	OUTLINE	DESCRIPTION	WT. gr/m	Jxx cm ⁴ Jyy cm ⁴
TT 6138		92mm CROSSPIECE FOR FIXED DOORS/WINDOWS AND ROUNDED LEAVES – FIX CLAMP	1690	30.60 24.85
TT 6139		92mm CROSSPIECE FOR 70mm SMOOTH LEAVES	1829	39.51 26.30
TT 6140		165mm CENTRAL CROSSBEAM FOR FIXED DOORS/WINDOWS AND ROUNDED LEAVES	3249	57.15 224.80
TT 6141		165mm BASE FOR FIXED DOORS/ WINDOW AND ROUNDED LEAVES	3245	60.80 238.30
TT 6142		Z FRAME, SECTION 65 mm	1335	27.42 9.13
TT 6143		L FRAME, SECTION 65 mm	1227	22.92 6.26
TT 6147		FITTED BASE FOR FIXED DOORS/WINDOWS AND ROUNDED LEAVES	2269	41.35 82.15
TT 6148		FITTED BASE FOR 70mm SMOOTH LEAVES	2332	51.15 84.50
TT 6158		165mm CENTRAL CROSSBEAM FOR 70mm SMOOTH LEAVES	3341	74.93 241.63
TT 6159		165mm BASE FOR 70mm SMOOTH LEAVES	3337	75.41 241.72
TT 6162		Z FRAME, FLUSH CONCAVE	1495	38.07 11.84
TT 6166		L FRAME, FLUSH CONCAVE COMBINED WITH TT 6162	1313	27.83 6.61
TT 6168		COLUMN FOR GLAZING	2498	128.01 33.51
TT 6169		HALF COLUMN FOR GLAZING	1899	89.26 7.24

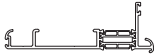
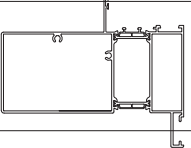

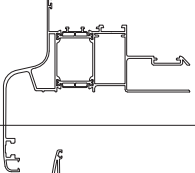

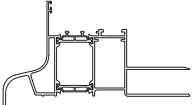
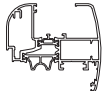

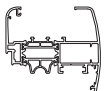
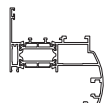
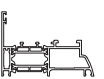
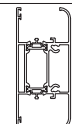
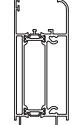

*it is advisable to use a counterprofile when cutting at 45°

ITEM	OUTLINE	DESCRIPTION	WT. gr/m	Jxx cm ⁴ Jyy cm ⁴
TT 6171		T FRAME, SECTION 67 mm	1389	27.31 9.83
TT 6172		Z FRAME, SECTION 67 mm	1381	29.87 9.69
TT 6173		L FRAME, SECTION 67 mm	1273	24.46 6.51
TT 6175		ROUND LEAF, SECTION 75 mm	1556	36.90 12.00
TT 6176 *		ROUND BEADLESS GLAZING LEAF, SECTION 80 mm, GLASS SPACE 42 mm	1778	50.77 17.43
TT 6180		120mm STAVE – 32mm THICK	1528	- -
TT 6181		MEDIUM FIXED T FRAME	1490	27.06 16.35
TT 6182		MEDIUM FIXED Z FRAME	1488	28.83 16.04
TT 6183		MEDIUM FIXED L FRAME	1381	24.61 12.03
TT 6186		GLAZING COUNTER-FRAME	1058	20.63 4.67
TT 6195		PROFILE FOR COMBINING WITH PLANET SIRIO FACADE	1302	19.96 10.20
TT 6199		90° ANGLE COLUMN	2066	40.00 49.23
TT 61123		REBATE REVERSAL	1230	19.07 6.15
TT 61138		92 mm CROSSPIECE FOR FIXED DOORS/WINDOWS - SCREW FASTENING	1755	31.12 25.50

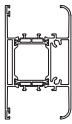
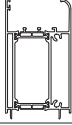



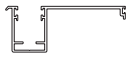

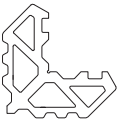

*it is advisable to use a counterprofile when cutting at 45°

ITEM	OUTLINE	DESCRIPTION	WT. gr/m	Jxx cm ⁴ Jyy cm ⁴
TT 61151 *		BEADLESS GLAZING LEAF GLASS SPACE 30 mm	1715	22.45 13.30
TT 61161		SINGLE-UNIT SHOULDER WITH EXPANSION JOINT	2622	- -
TT 61163		SINGLE-UNIT OPEN SHOULDER WITH DOUBLE EYE BOLT FOR FASTENING	2446	- -
TT 61164		SINGLE-UNIT CLOSED SHOULDER WITH DOUBLE EYE BOLT FOR FASTENING	3305	- -
TT 61165		FIXED L FRAME UPPER CROSSPIECE SINGLE-UNIT	1247	- -
TT 61166		SINGLE-UNIT TOP COVER/SHOULDER COVER/SUPPORT FOR BRACKET/SUPPORT FOR CASING	1249	- -
TT 61264		SINGLE-UNIT CLOSED SHOULDER WITHOUT ROLLER SHUTTER GUIDE	2922	- -
TT 61313		SMOOTH CENTRAL CONNECTION PROFILE	1454	27.07 7.80
TT 61325		INDUSTRIAL SHED FRAME	2855	178.93 85.51
TT 61413		ROUNDED CENTRAL CONNECTION PROFILE	1587	32.07 10.07
TT 61425		INDUSTRIAL SHED FRAME	2779	162.34 85.09
TT 61451		ROUND BEADLESS GLAZING LEAF, GLASS SPACE 30 mm	1735	38.53 15.53
TT 6202		FIXED Z FRAME – FLUSH 22mm FIN	1391	31.60 10.65
TT 6203		FIXED L FRAME – FLUSH	1210	24.15 5.85

*it is advisable to use a counterprofile when cutting at 45°

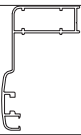
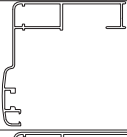
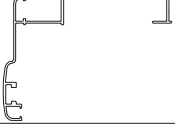
ITEM	OUTLINE	DESCRIPTION	WT. gr/m	Jxx cm ⁴ Jyy cm ⁴
TT 62151 *		BEADLESS GLAZING LEAF, GLASS SPACE 42 mm	1461	40.26 14.44
TT 6222		FIXED Z FRAME - FLUSH 30 mm FIN	1463	36.09 14.64
TT 6223		FIXED L FRAME – FLUSH	1209	24.39 5.77
TT 51153		94mm BEADLESS GLAZING CROSSPIECE, GLASS SPACE 30 mm	1844	15.60 35.10
TT 51248		BEADLESS GLAZING FITTED BASE, GLASS SPACE 30 mm	2069	16.30 56.35
TT 52152		165mm GLASS INSERT CENTRAL CROSSBEAM GLASS SPACE 30 mm	3345	29.47 241.80
TT 61153		94 mm BEADLESS GLAZING CROSSPIECE, GLASS SPACE 42mm	1926	30.94 38.6
TT 61248		FITTED BASE GLASS INSERT GLASS SPACE 42mm	2142	33.08 64.66
TT 62152		165mm BEADLESS GLAZING CROSSBEAM, GLASS SPACE 42 mm	3427	58.29 282.02
PL 2055		BRUSH HOLDER FOR TT 6140 AND TT 6141	672	- -
PL 2058		TREADABLE SILL	404	- -
PL 2060		ROLLER SHUTTER GUIDE	947	- -
PL 2067		25mm FITTED REBATE FOR SINGLE-UNIT HALF SHOULDER TT 6161	205	- -
PL 2075		GLAZING JOINT PROFILE	528	- -

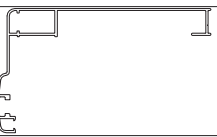
*it is advisable to use a counterprofile when cutting at 45°

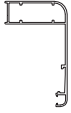
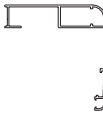













ITEM	OUTLINE	DESCRIPTION	WT. gr/m	Jxx cm ⁴ Jyy cm ⁴
PL 2077		GLAZING COUNTER-FRAME	385	- -
PL 2084		PROFILE FOR OVERSIZED BRACKETS, CRIMPING	6461	- -
PL 2090		PROFILE FOR BRACKETS, CRIMPING	2720	- -
PL 20100		DRIP	129	- -
PL 20126		LOW SILL REINFORCEMENT	260	- -
PL 20128		22mm FITTED REBATE FOR FIXED DOORS/WINDOWS Z FRAMES	190	- -
PL 20193		45mm WALL PROFILE	946	- -
PL 20194		75mm WALL PROFILE	1149	- -
PL 20195		105mm WALL PROFILE	1306	- -
PL 20196		90mm WALL PROFILE EXTENSION	686	- -
PL 20198		135mm WALL PROFILE	1504	- -
PL 20226		CABLE COVER PROFILE FOR TT 61325, TT 6163, TT 6164	95	- -
PL 20293		48.5mm WALL PROFILE	832	- -
PL 20294		78.5mm WALL PROFILE	1022	- -

*it is advisable to use a counterprofile when cutting at 45°









ITEM	OUTLINE	DESCRIPTION	WT. gr/m
PL 20295		108.5mm WALL PROFILE	1236
PL 20296		103mm WALL PROFILE EXTENSION	816
PL 20298		138.5mm WALL PROFILE	1472
AS 1000		SMALL ROD	119
AS 1001R		DRIP	127
AS 4864		LOWER AND UPPER BOX	1218
AS 4865		FRONT BOX	1110
AS 48167		CONVEX CABLE COVER PROFILE FOR SINGLE UNIT	160
PL 1404		3.5mm SMOOTH GLAZING BEAD	190
PL 1407		7mm SMOOTH GLAZING BEAD	206
PL 1411		10.5mm SMOOTH GLAZING BEAD	252
PL 1414		14mm SMOOTH GLAZING BEAD	257
PL 1418		17.5mm SMOOTH GLAZING BEAD	268
PL 1421		21mm SMOOTH GLAZING BEAD	290

SEE
 GLAZING
 PAGE 59

*it is advisable to use a counterprofile when cutting at 45°

ITEM	OUTLINE	DESCRIPTION	WT. gr/m
PL 1425		24.5mm SMOOTH GLAZING BEAD	304
PL 1428		27.5mm SMOOTH GLAZING BEAD	312
PL 1432		31.7mm SMOOTH GLAZING BEAD	331
PL 1435		35 mm TUBULAR SMOOTH GLAZING BEAD ALWAYS USE ACP 5027 RUBBER STRIP	434
PL 1439		38.5 mm TUBULAR SMOOTH GLAZING BEAD ALWAYS USE ACP 5027 RUBBER STRIP	444
PL 1442		41.5 mm TUBULAR SMOOTH GLAZING BEAD ALWAYS USE ACP 5027 RUBBER STRIP	453
PL 1511		10.2mm ROUNDED GLAZING BEAD	238
PL 1514		14mm ROUNDED GLAZING BEAD	247
PL 1518		17.5mm ROUNDED GLAZING BEAD	257
PL 1521		21mm ROUNDED GLAZING BEAD	279
PL 1525		24.5mm ROUNDED GLAZING BEAD	290
PL 1528		27.5mm ROUNDED GLAZING BEAD	301
PL 1532		31.7mm ROUNDED GLAZING BEAD	317
PL 1535		35mm ROUNDED GLAZING BEAD	337

SEE GLAZING PAGE 59

ITEM	OUTLINE	DESCRIPTION	WT. gr/m
PL 1539		38.5mm ROUNDED GLAZING BEAD	352
PL 1542		41.5mm ROUNDED GLAZING BEAD	365
PL 1818		17.5mm BEVELLED GLAZING BEAD	236
PL 1821		21mm BEVELLED GLAZING BEAD	258
PL 1825		24.5mm BEVELLED GLAZING BEAD	270
PL 1828		27.5mm BEVELLED GLAZING BEAD	279
PL 1832		31.7mm BEVELLED GLAZING BEAD	296
PL 1928		27.5mm MOULDED GLAZING BEAD	298
PL 1932		31.7mm MOULDED GLAZING BEAD	317

SEE GLAZING PAGE 59

I pesi dei profilati indicati in elenco sono teorici e possono scostarsi da quelli reali fino ad un massimo fattore moltiplicativo di 1,08

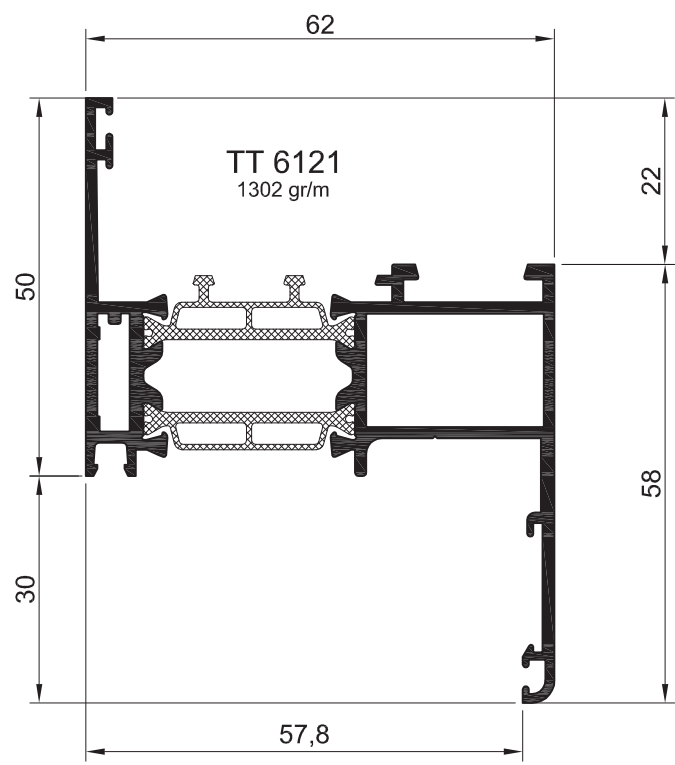
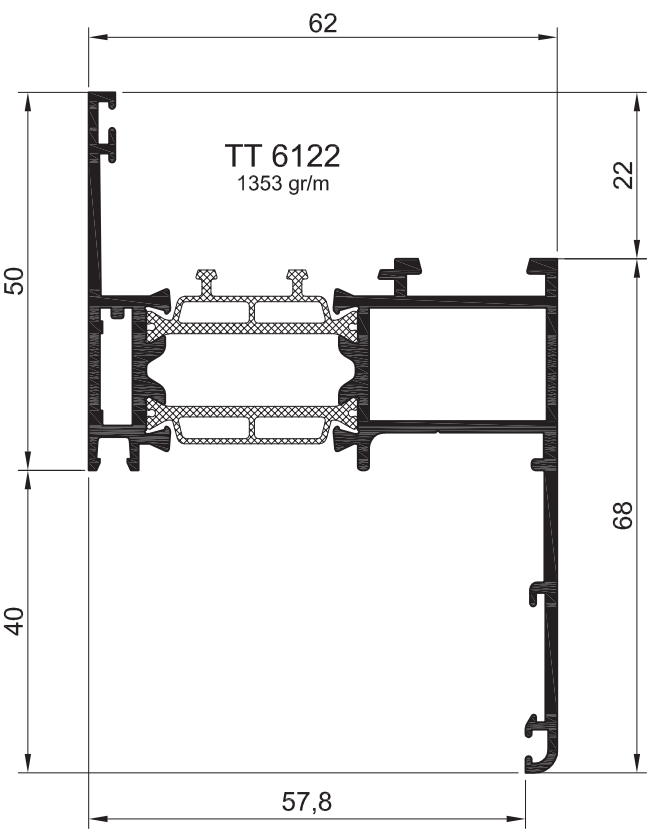
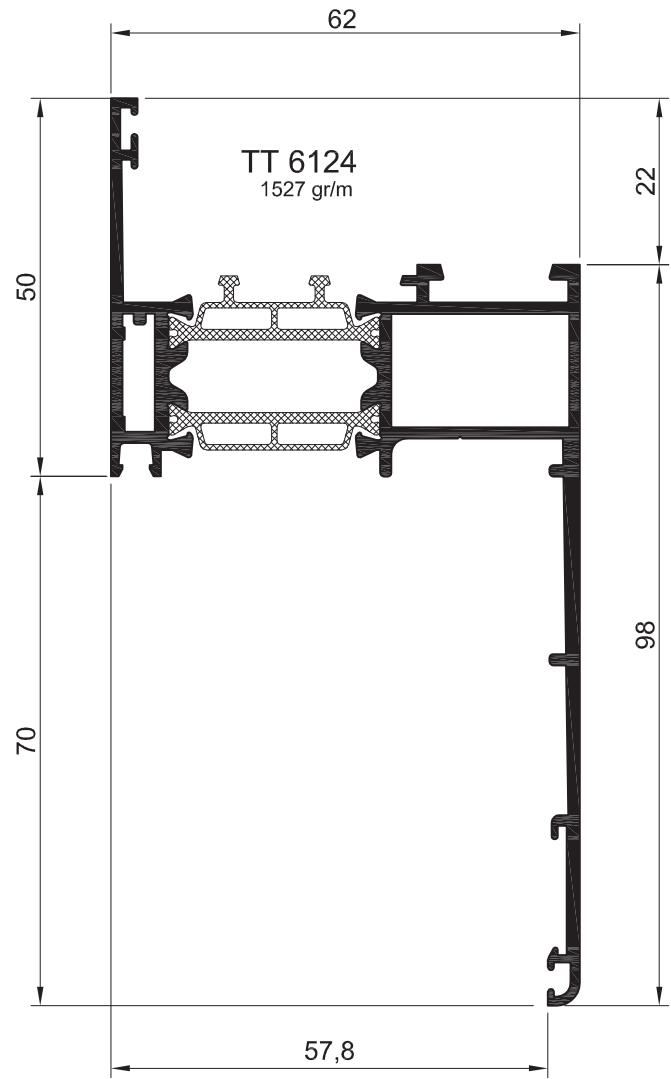
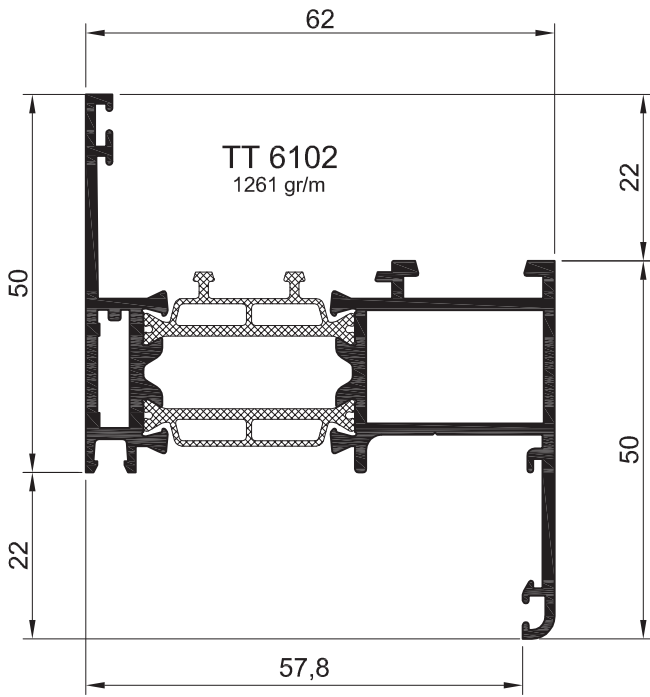

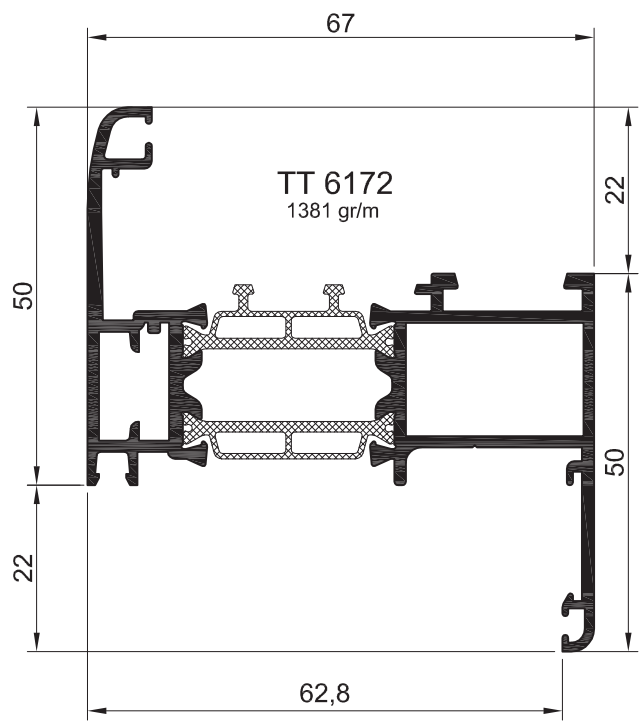
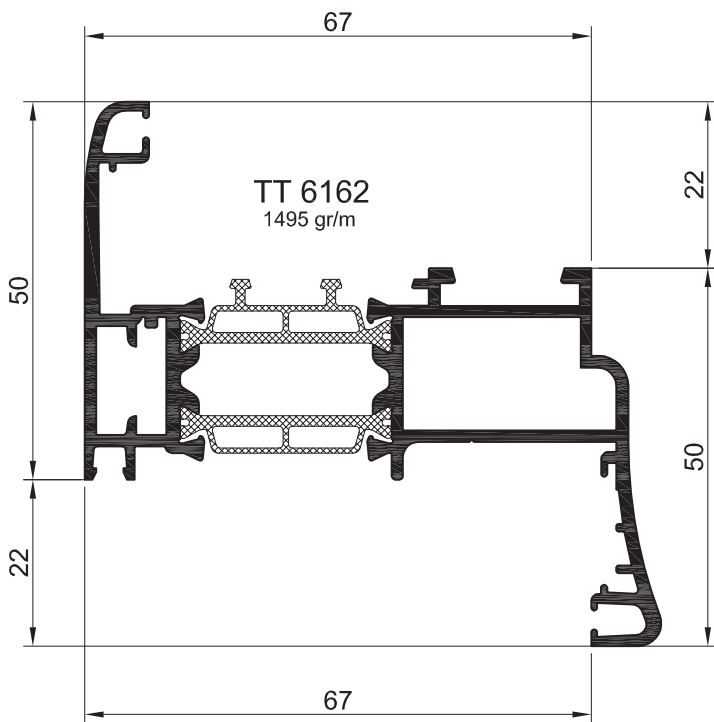
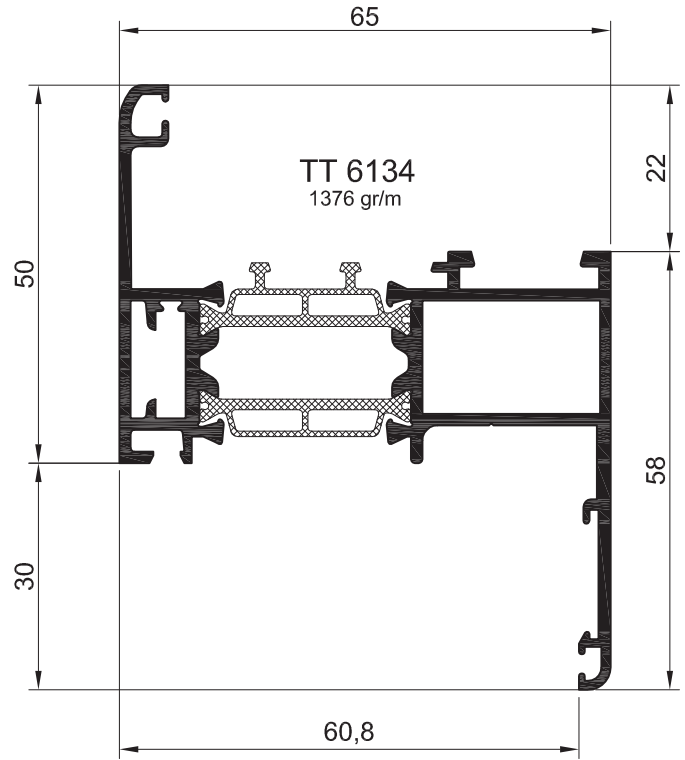
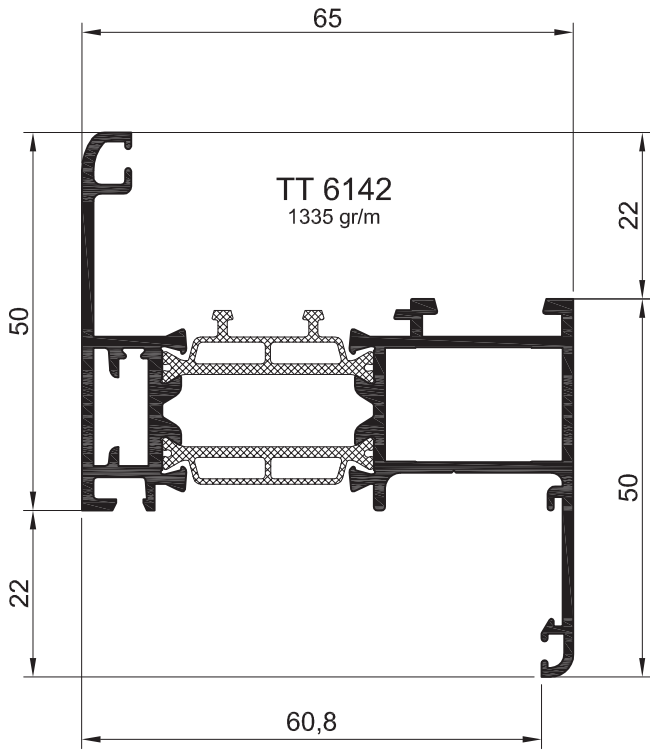

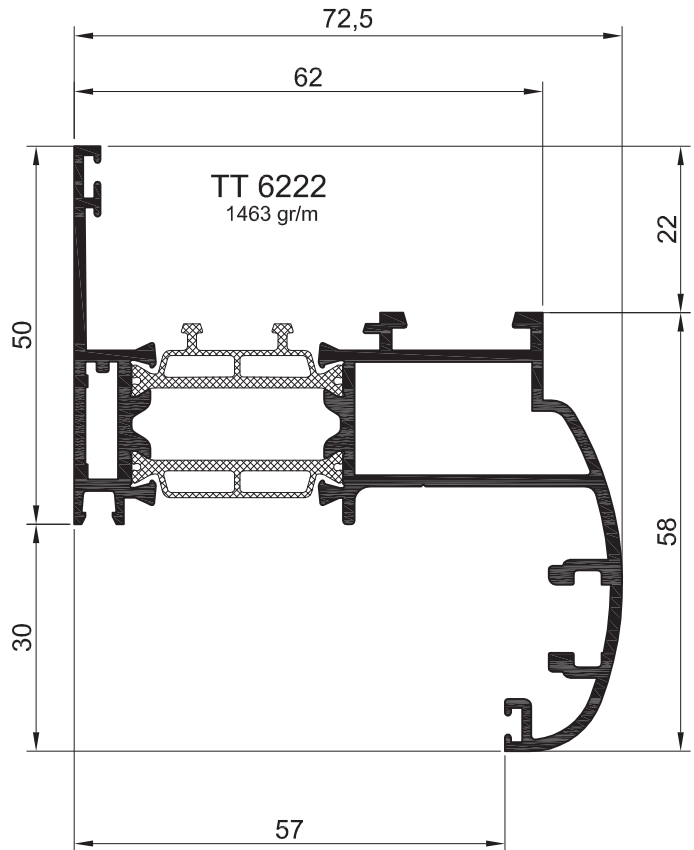
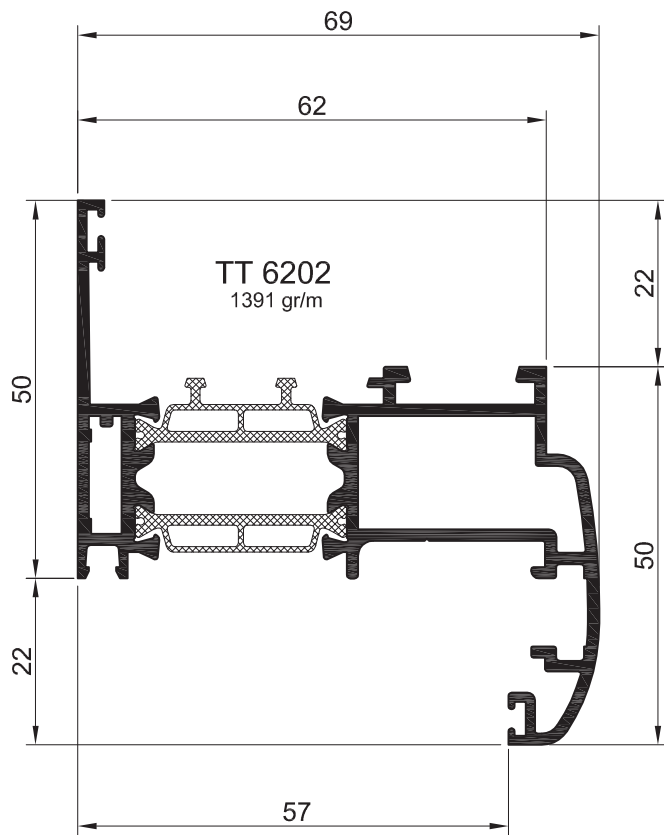
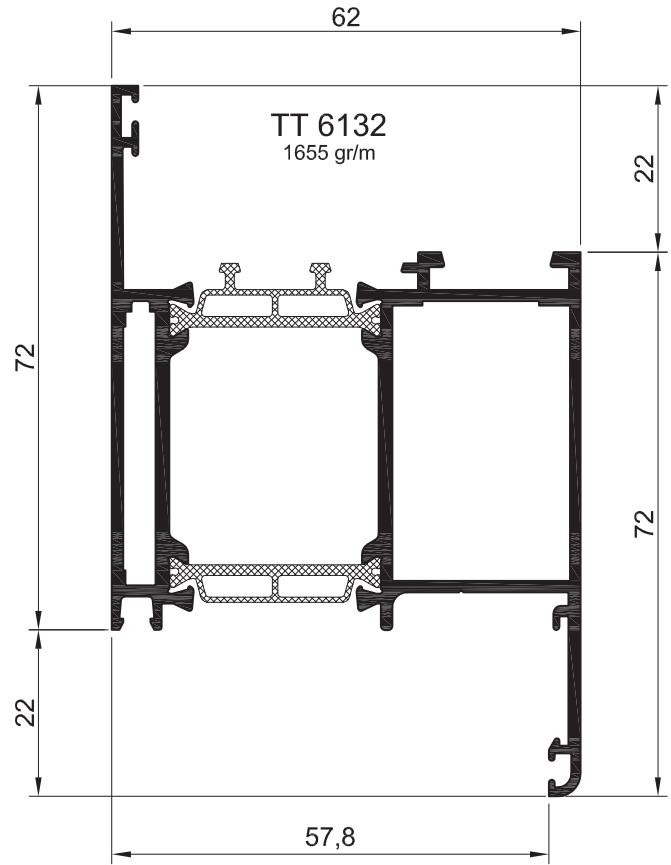
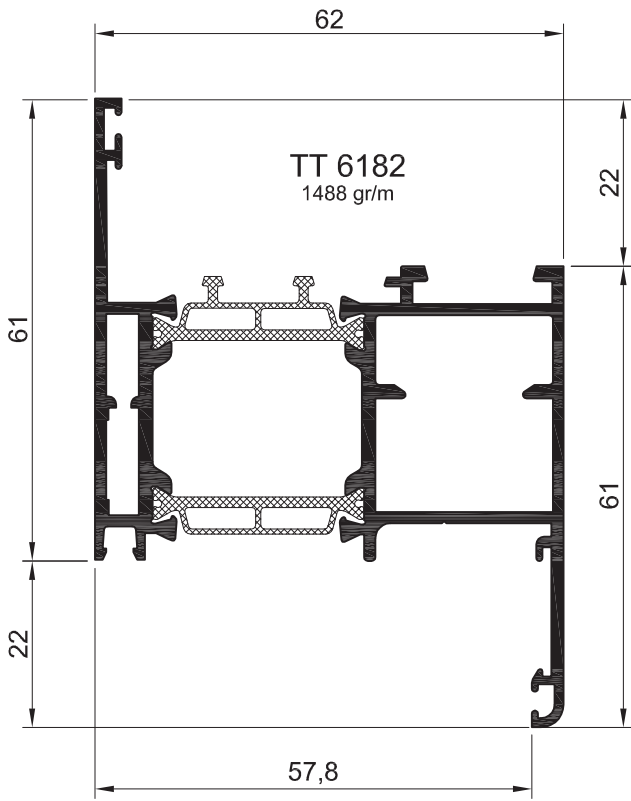

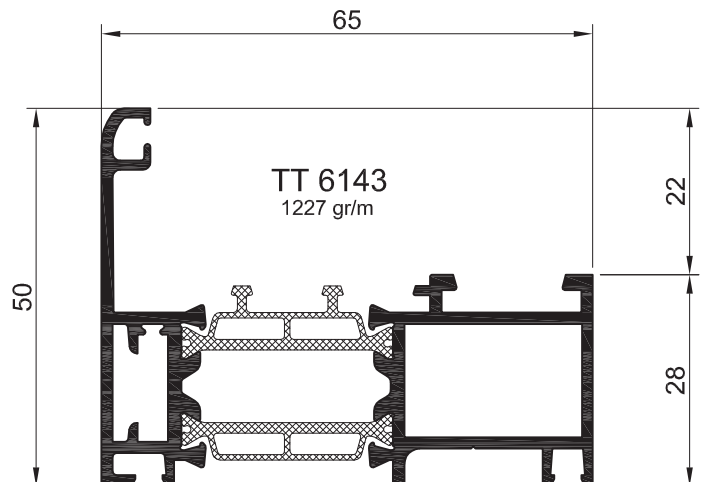
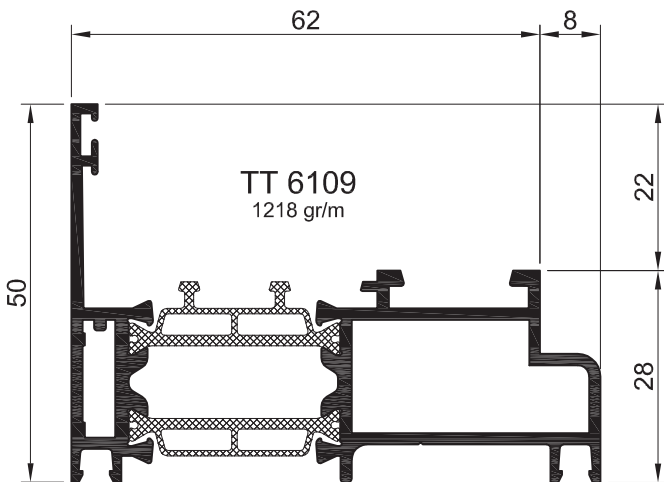
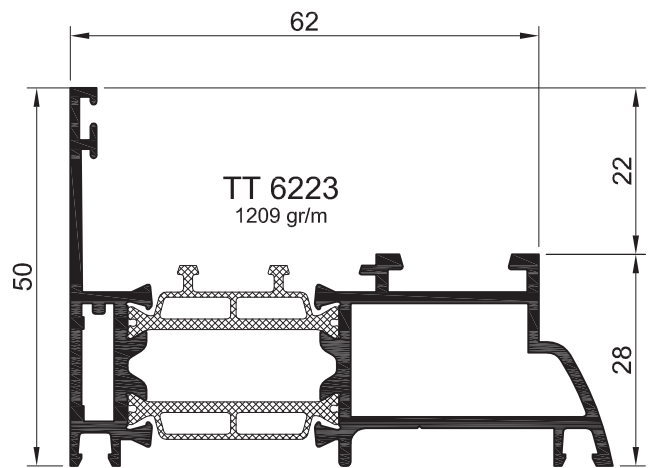
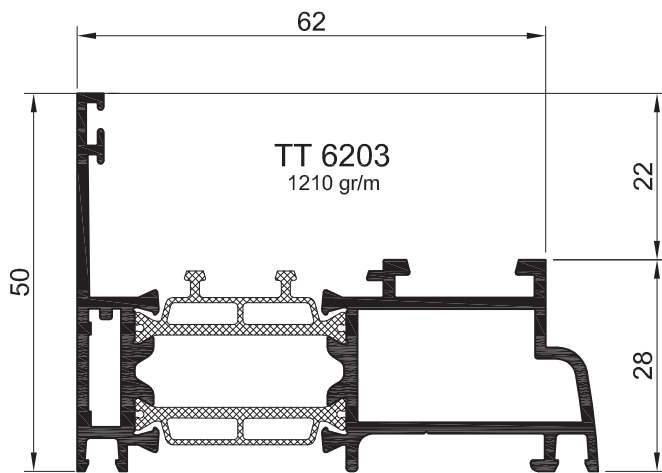
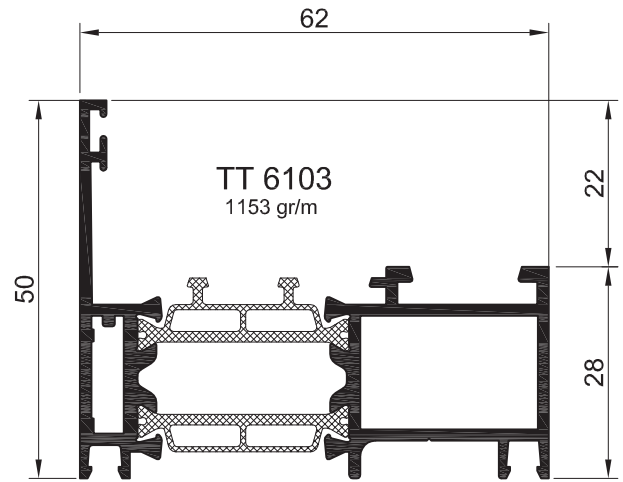
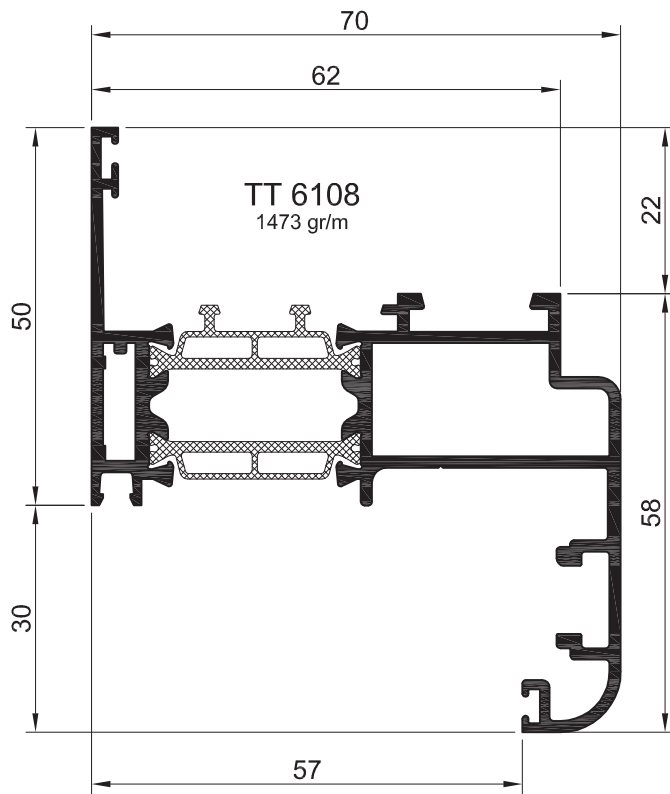

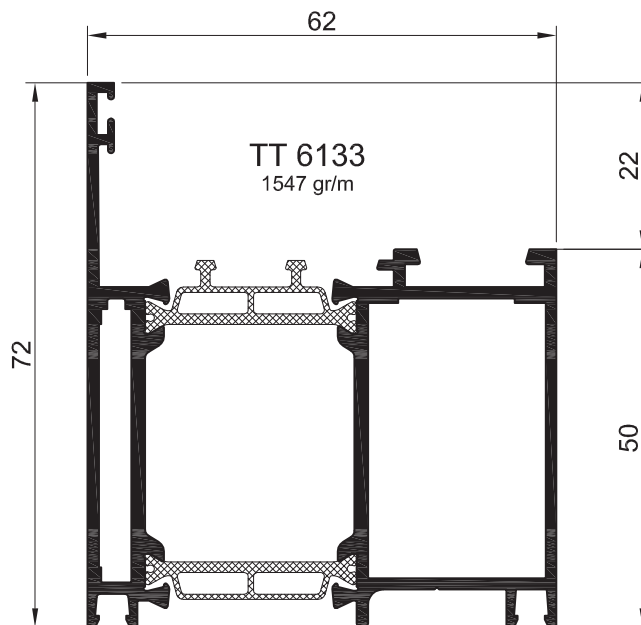
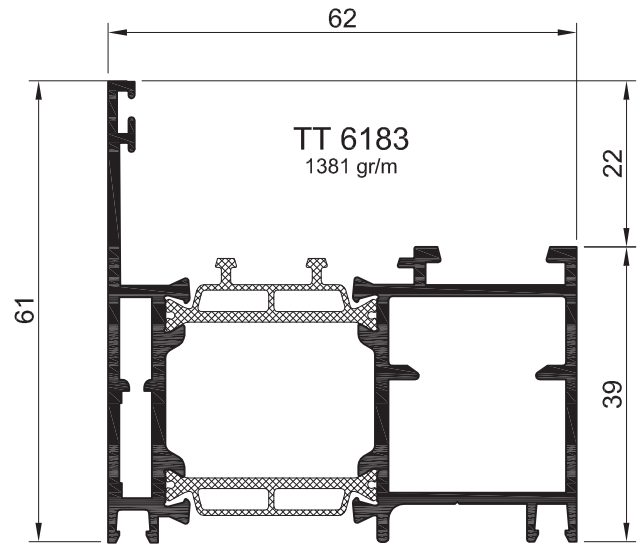
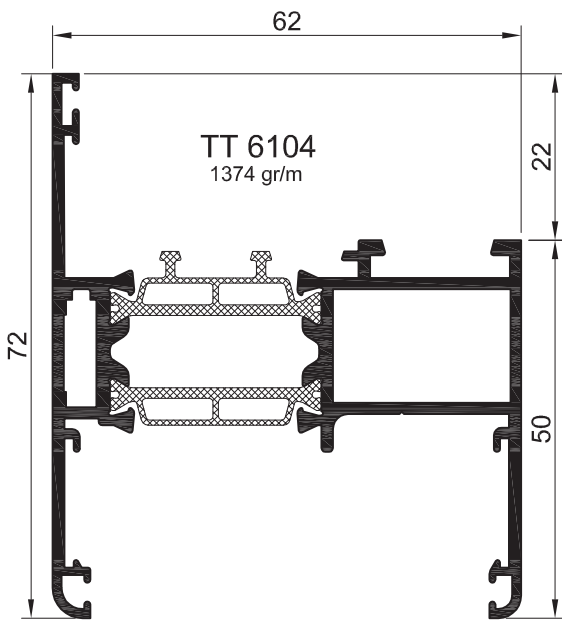
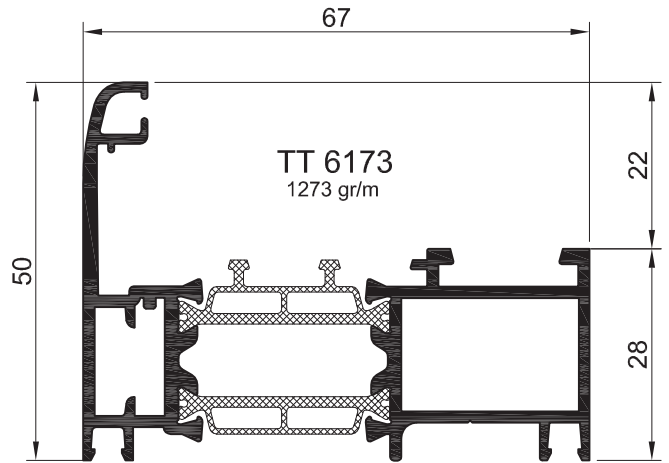
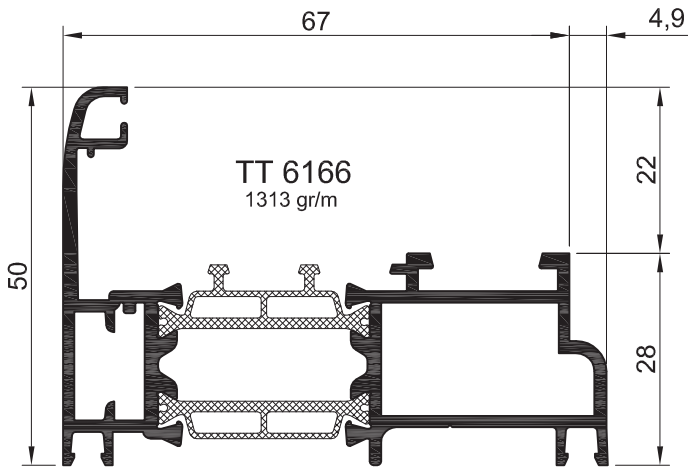

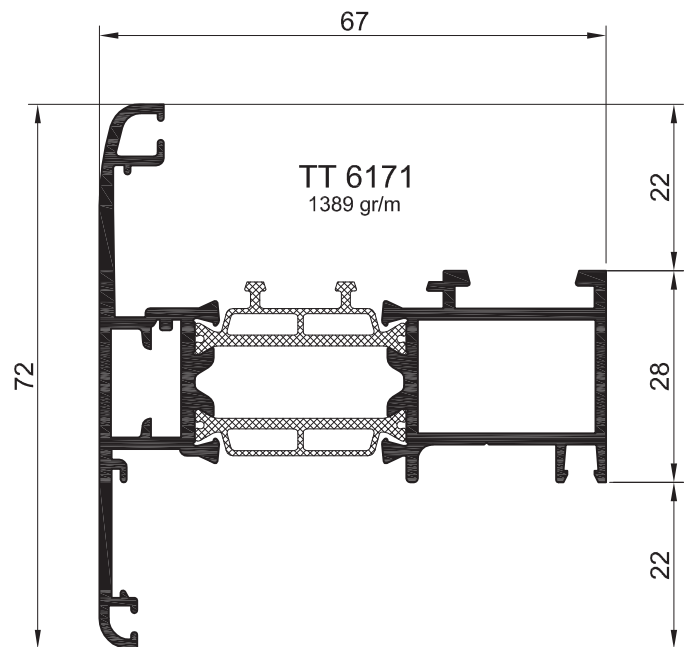
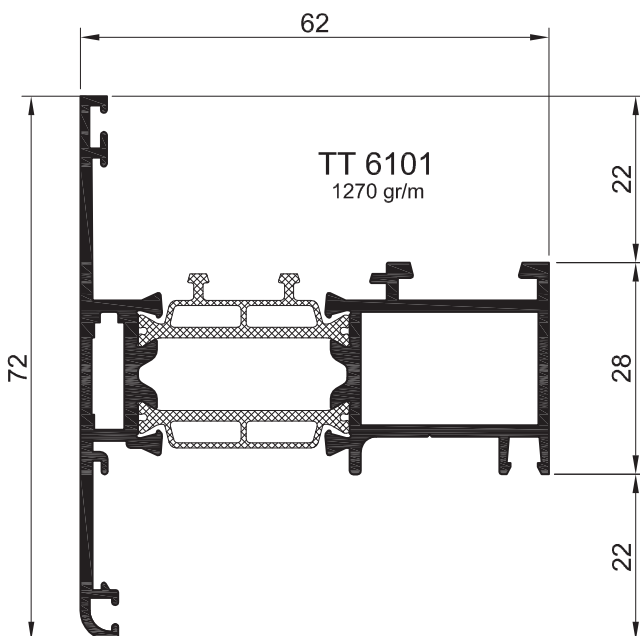
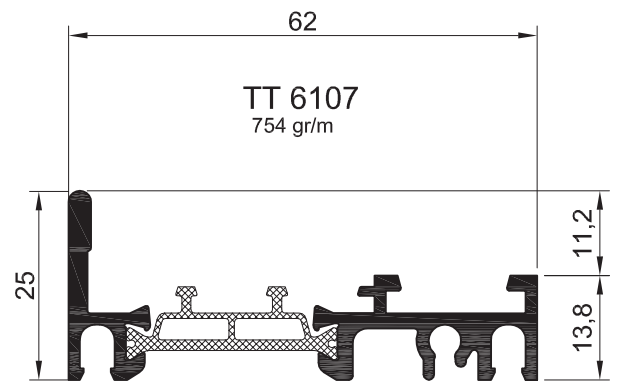
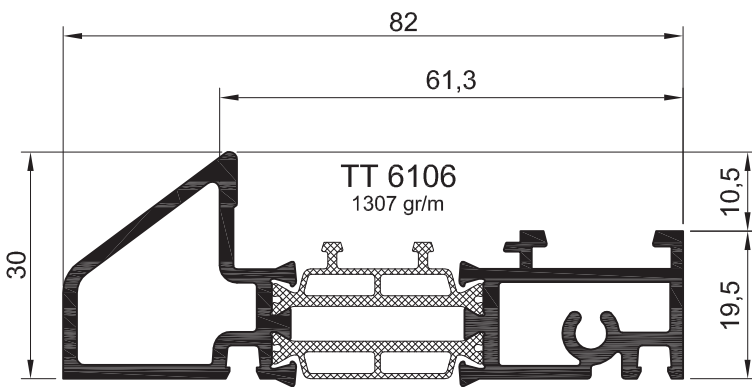

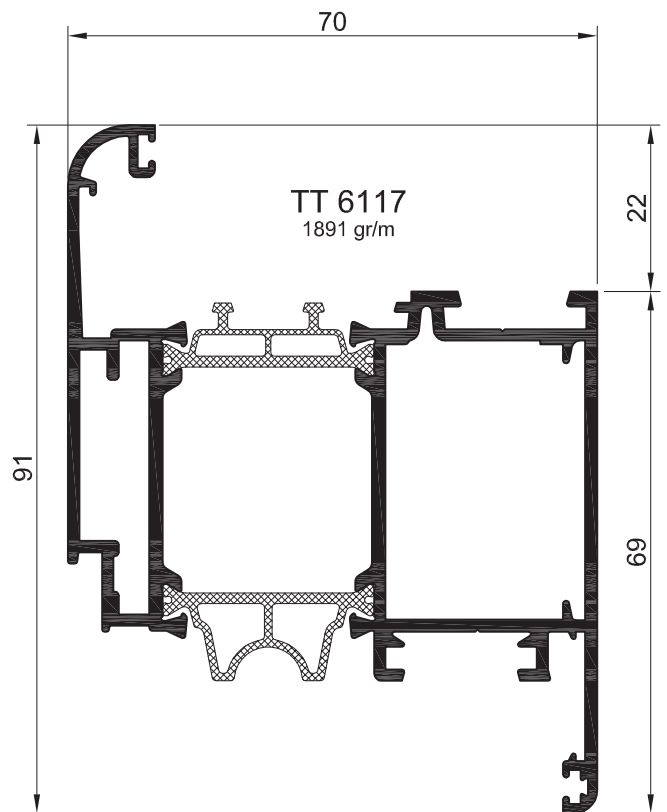
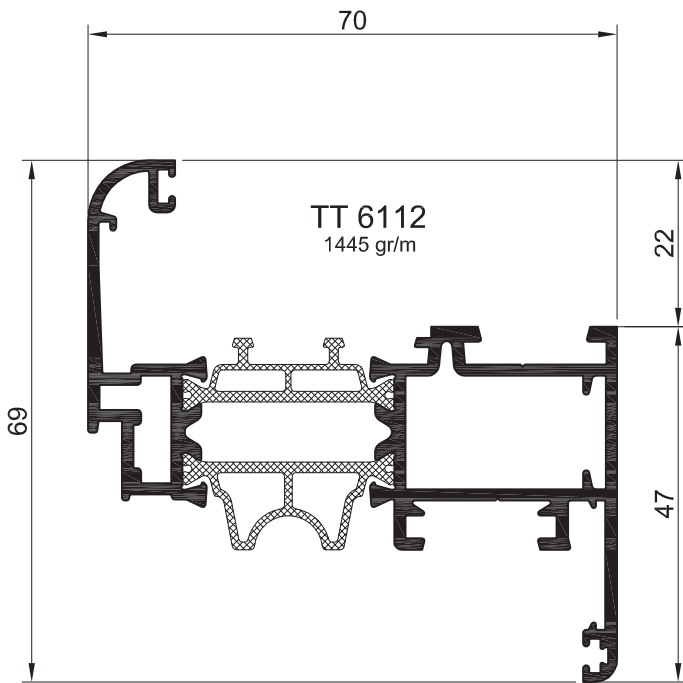
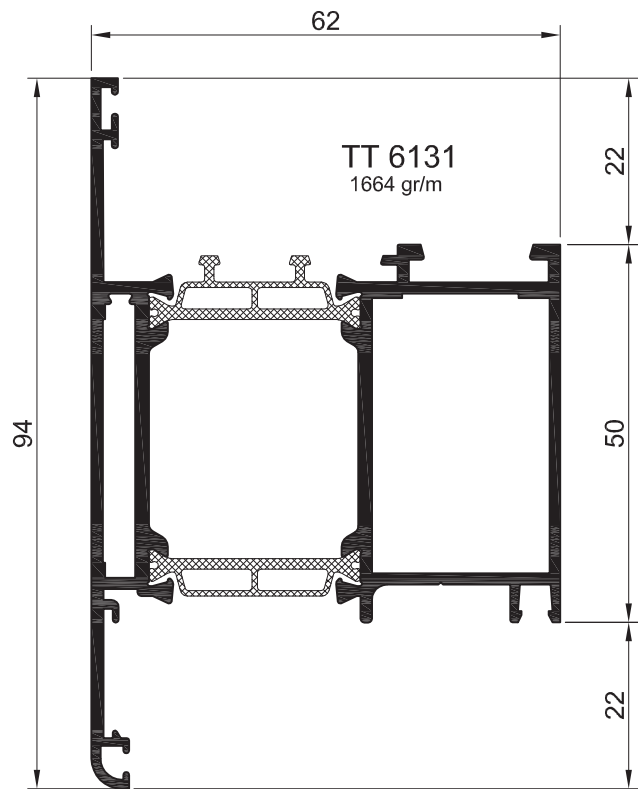
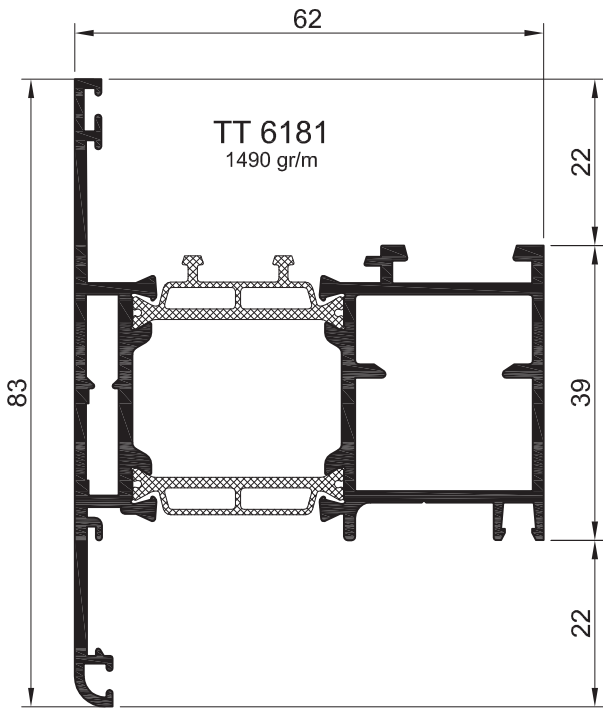

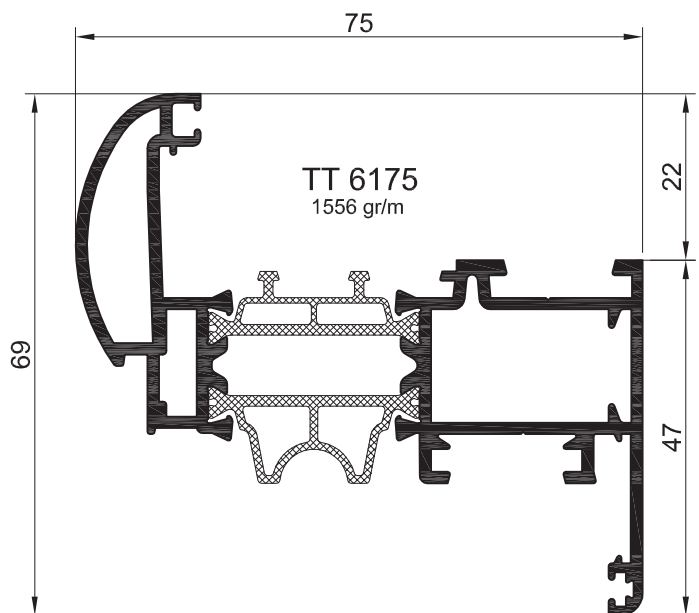
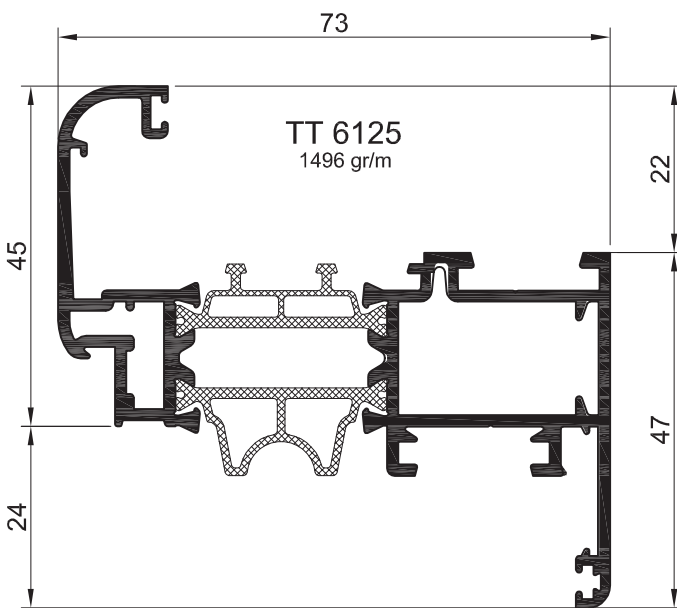
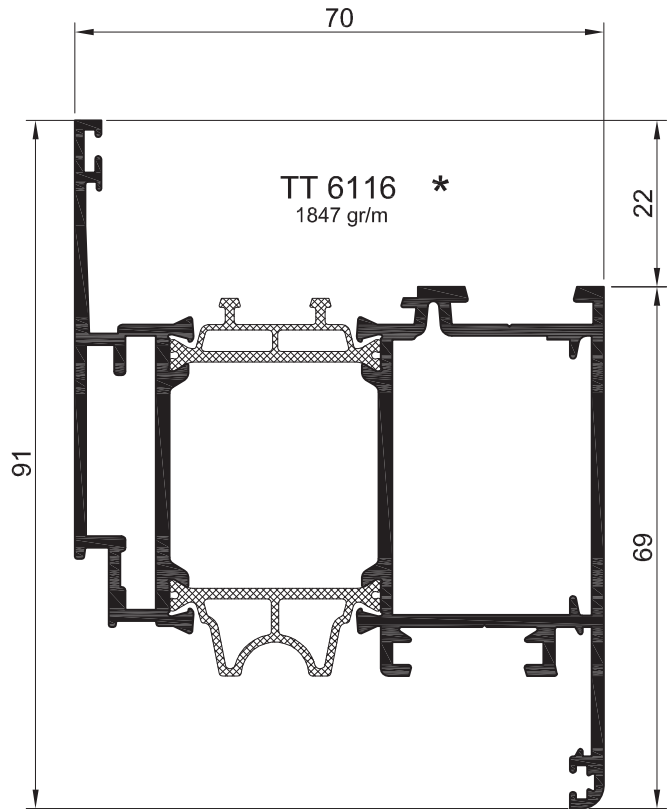
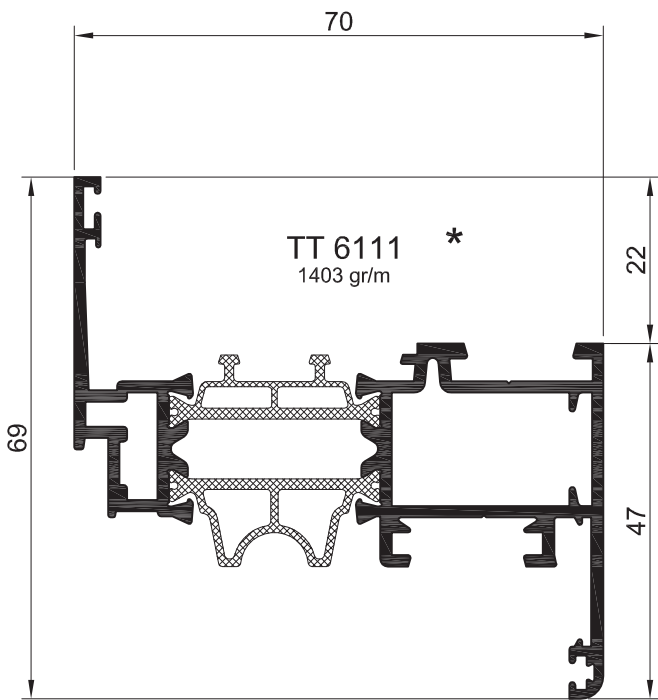

* always use external glass gasket AGP 4014

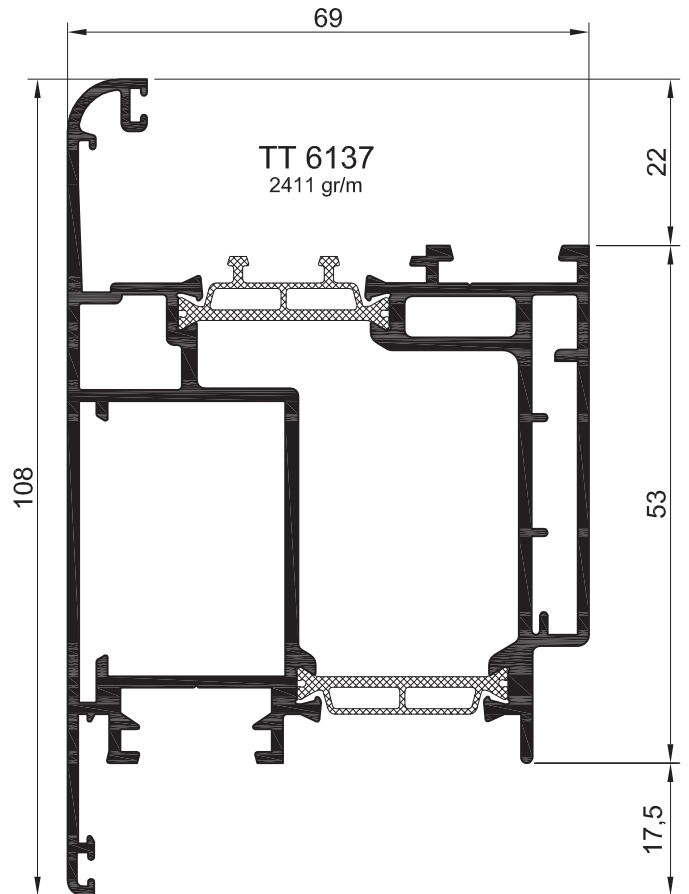
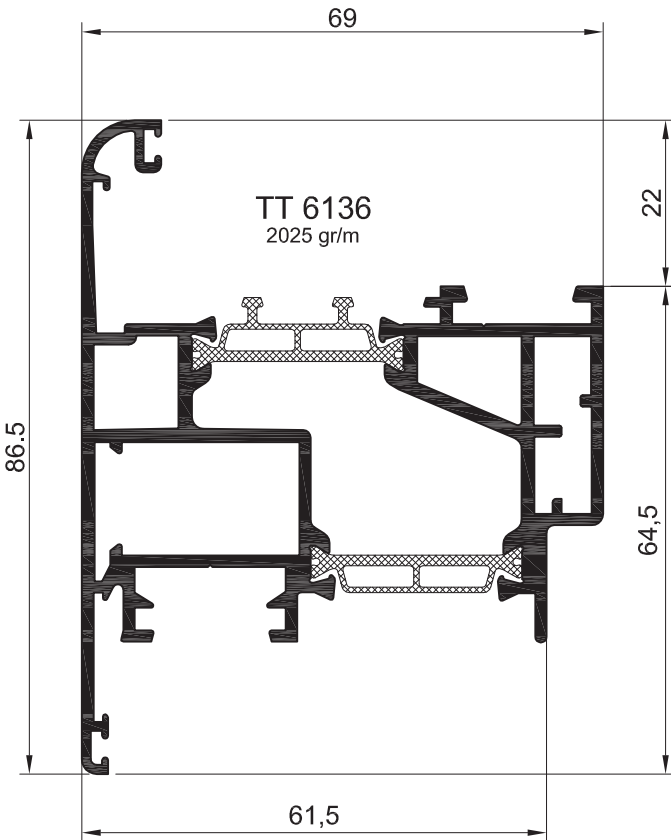
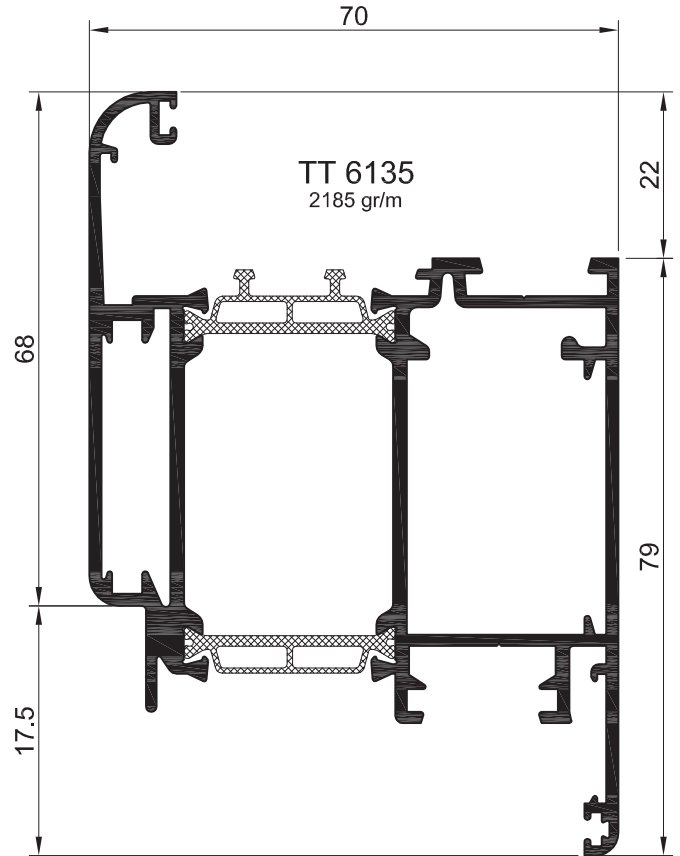
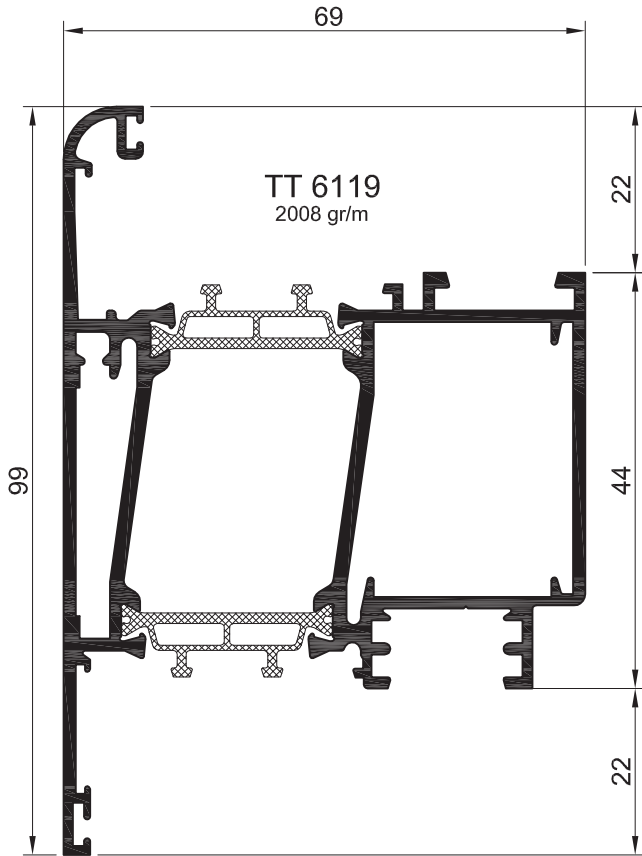

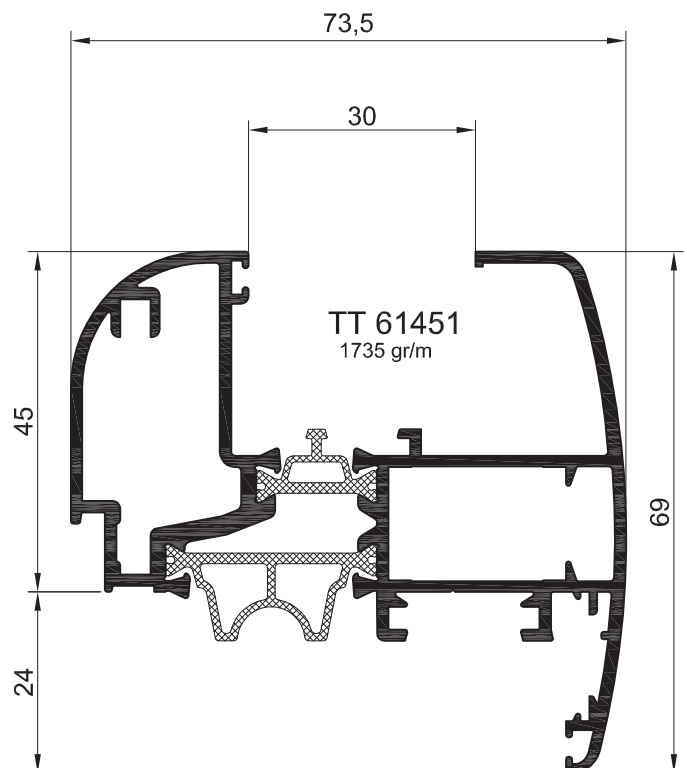
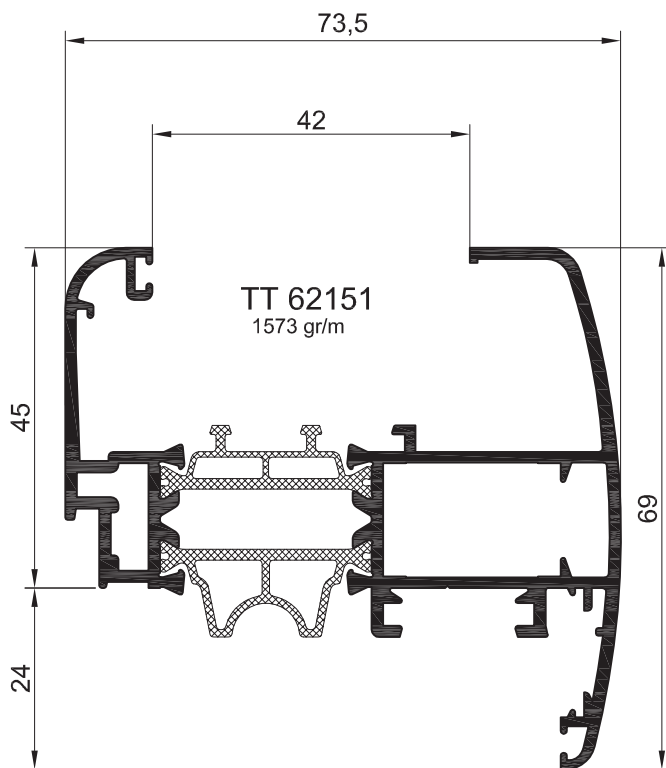
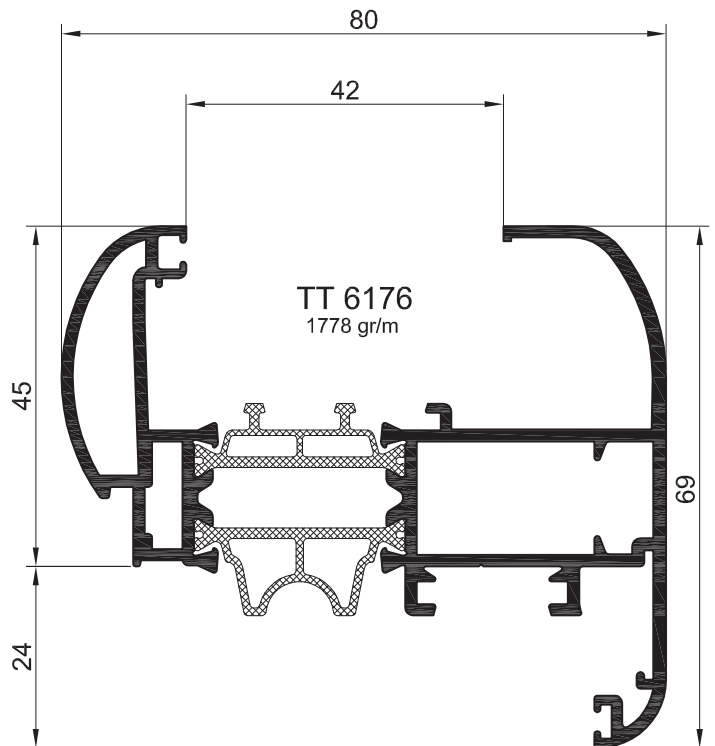
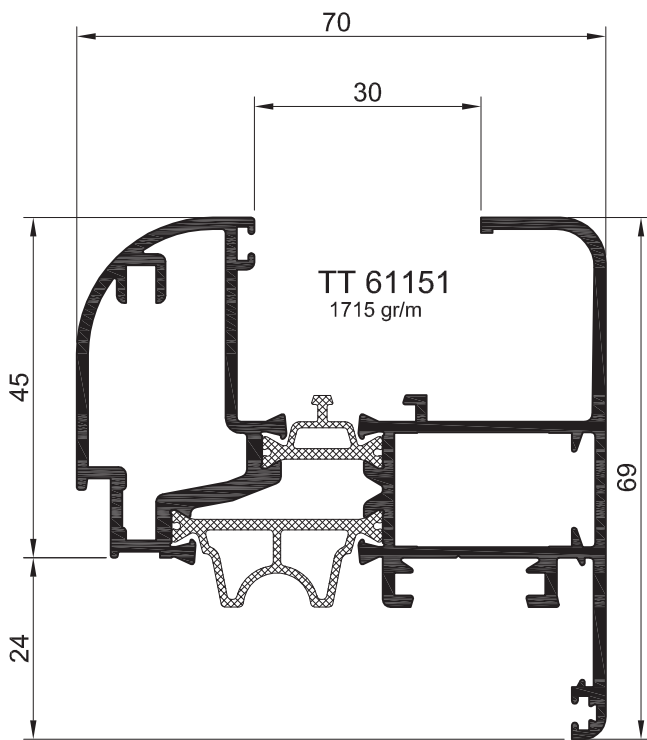

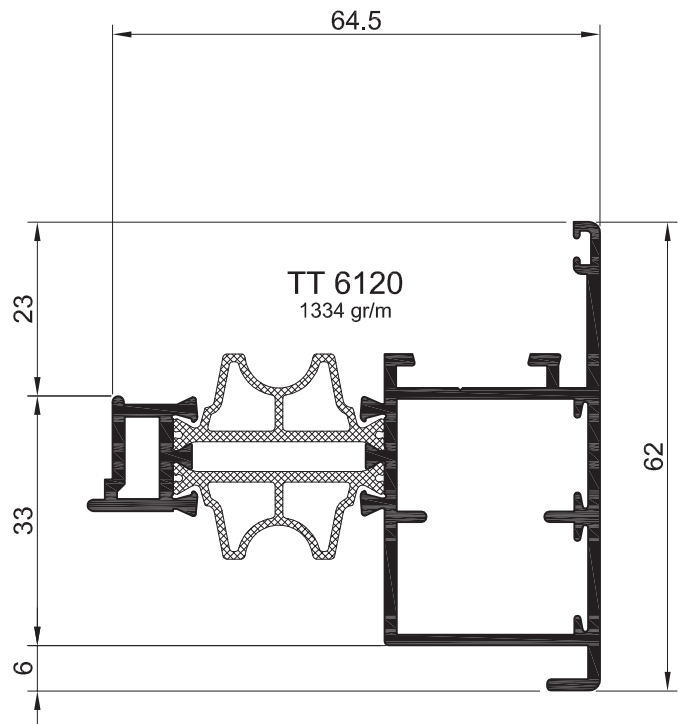
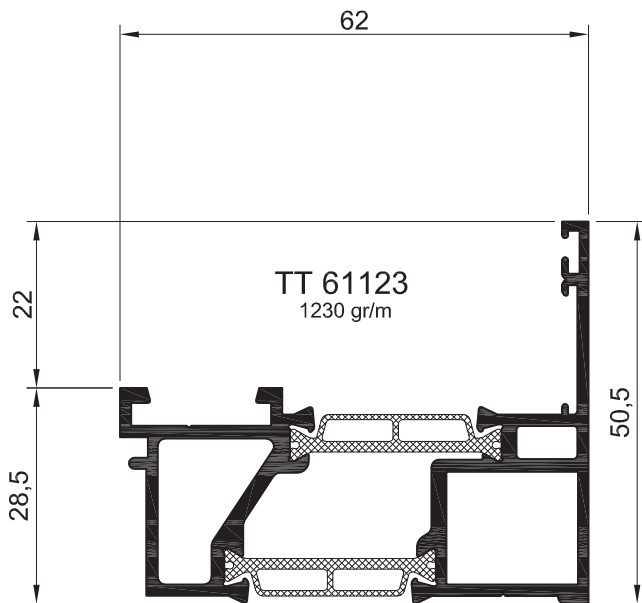
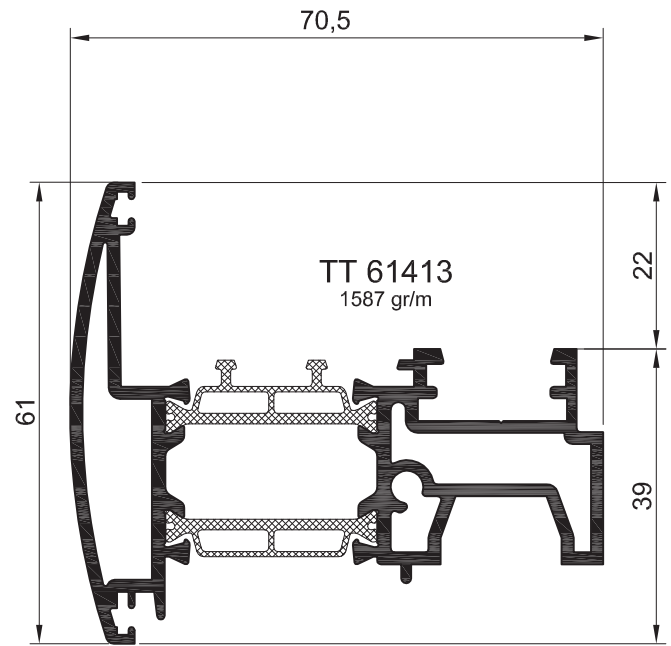
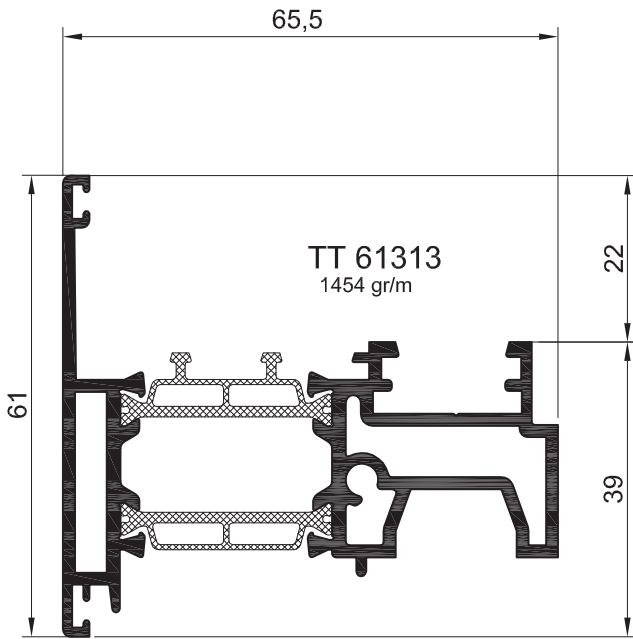

Profiles for perimetrical metal fittings

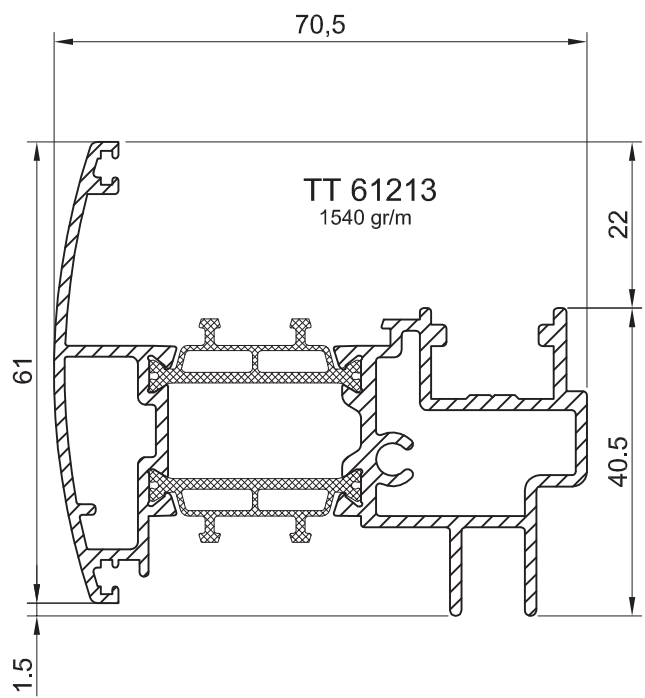
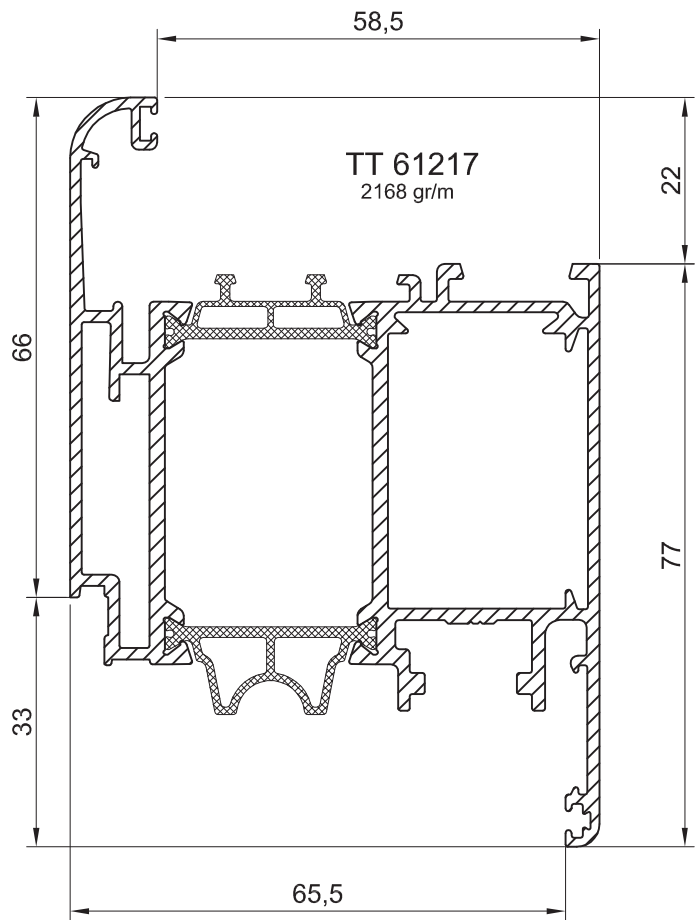
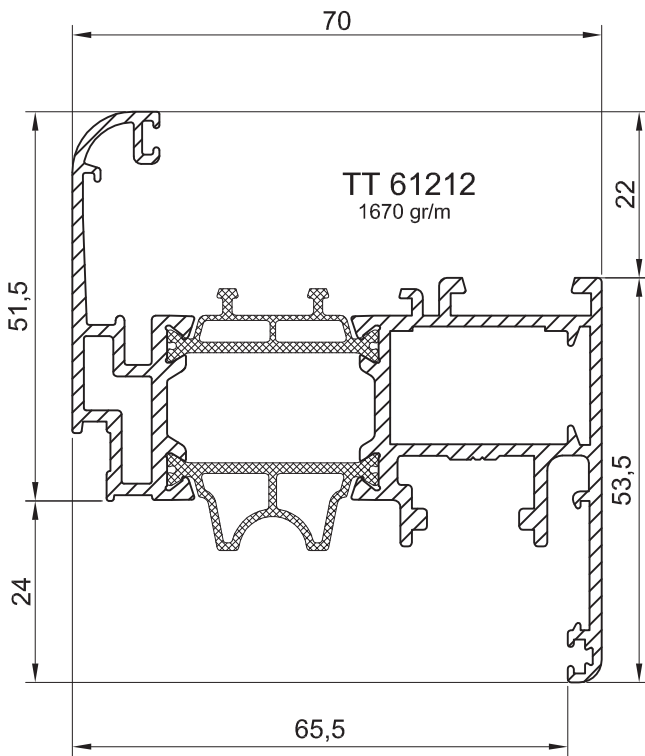

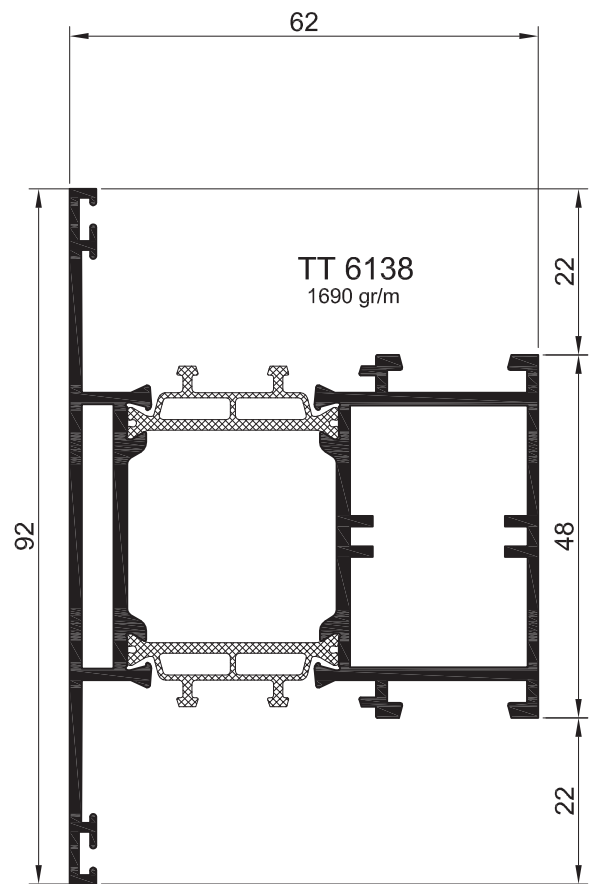
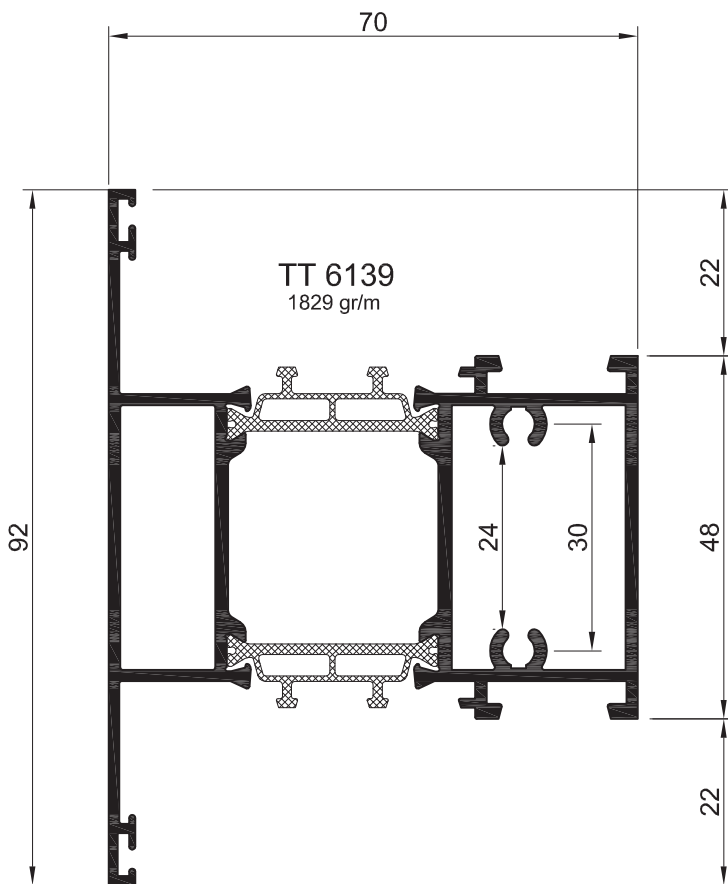
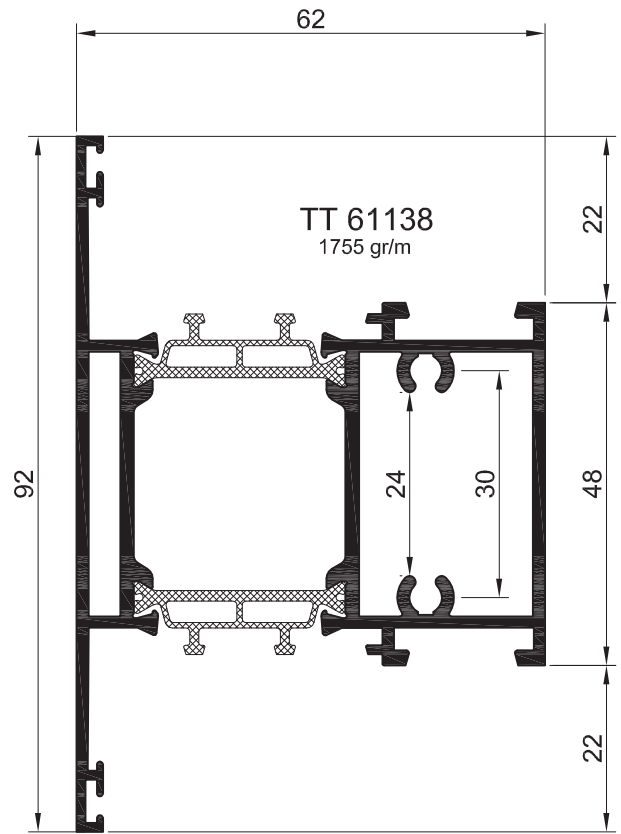
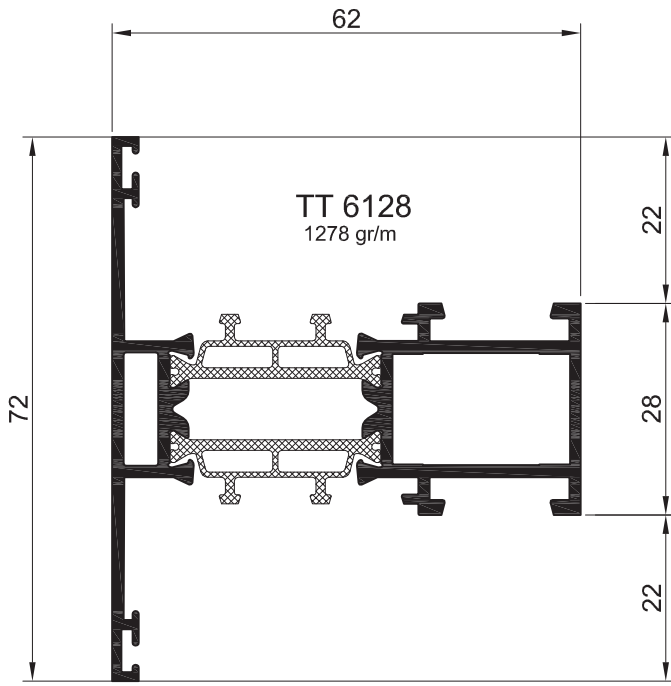

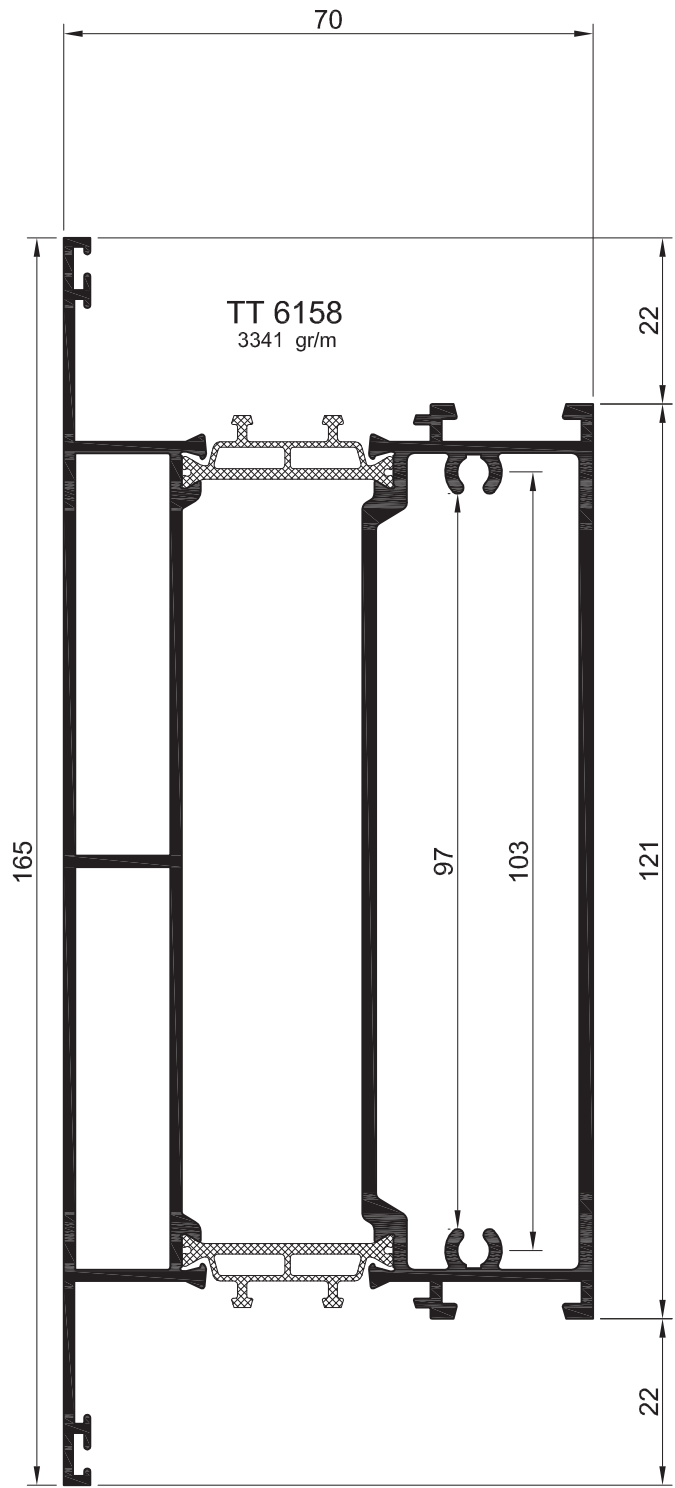
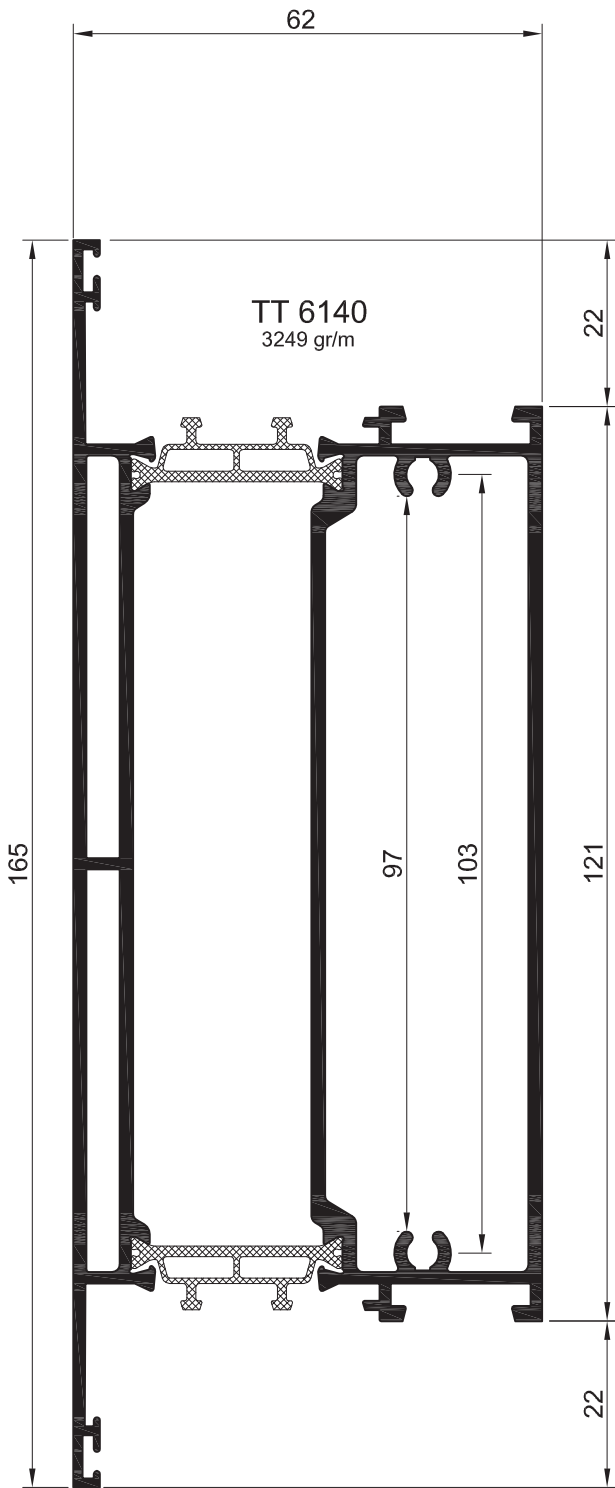

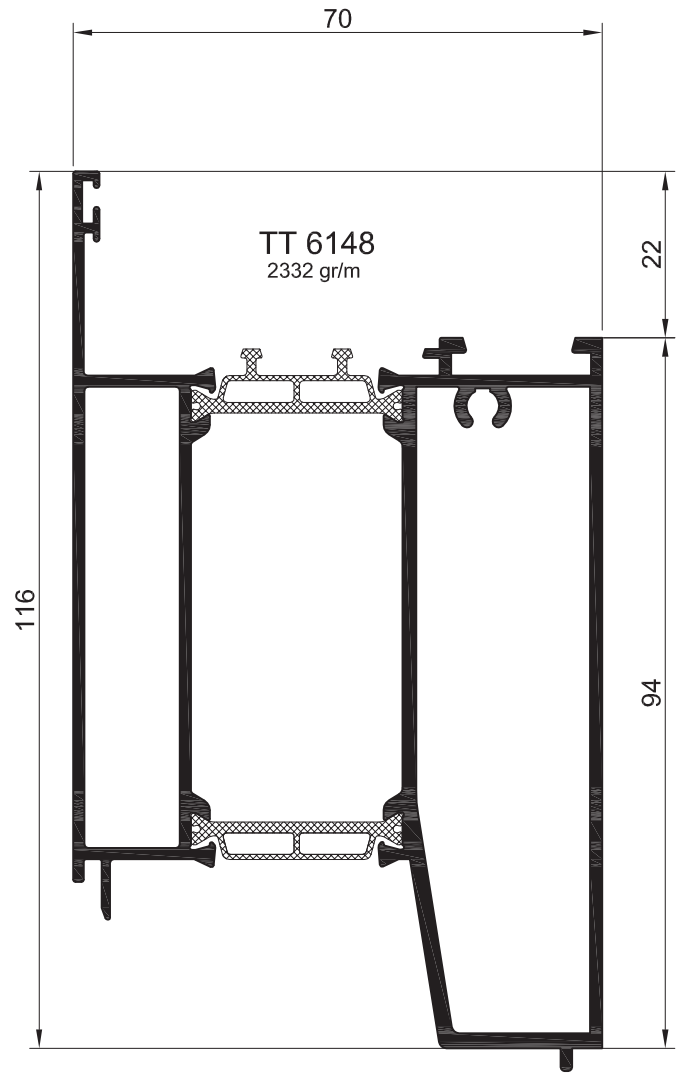
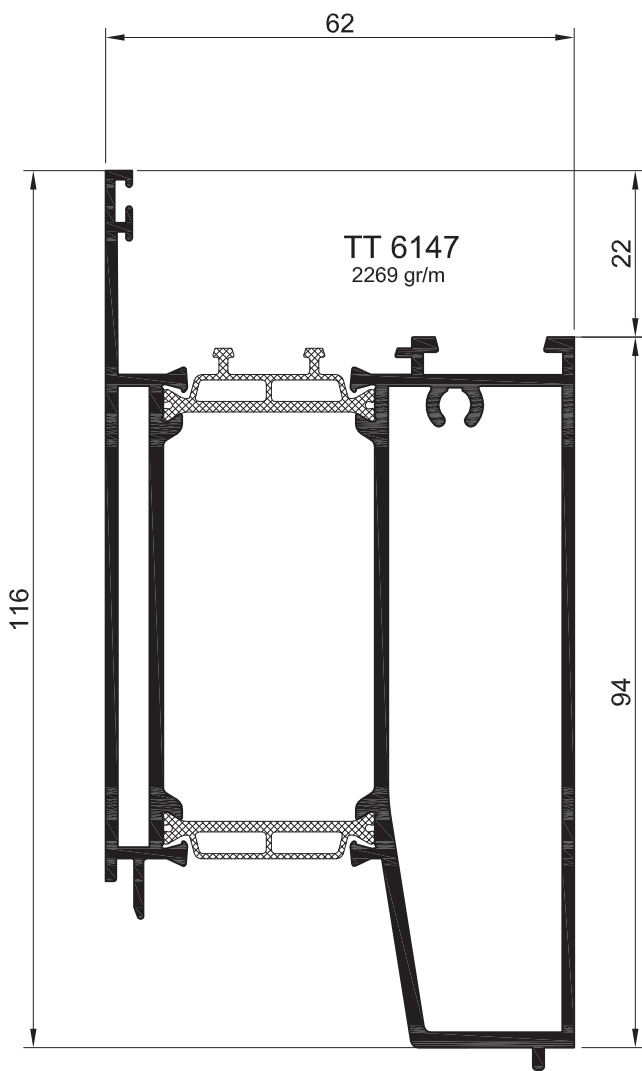

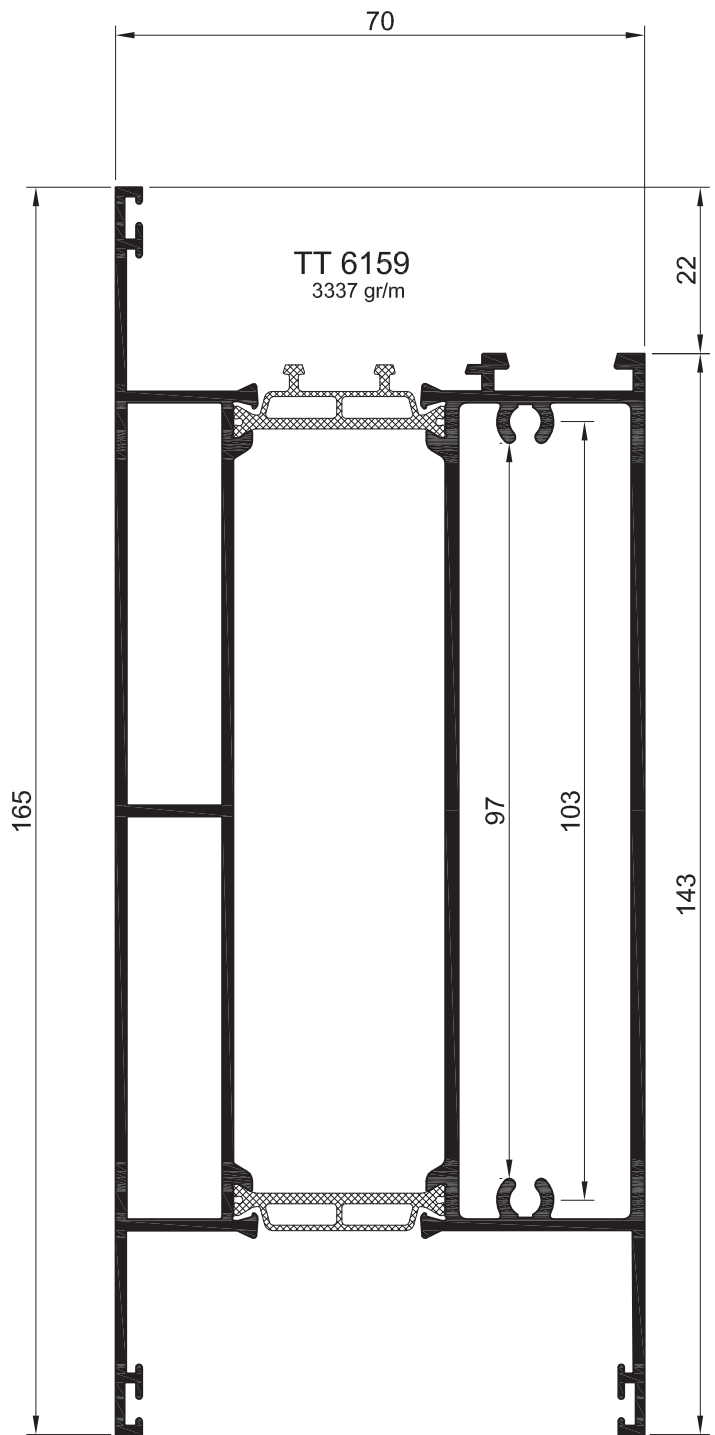
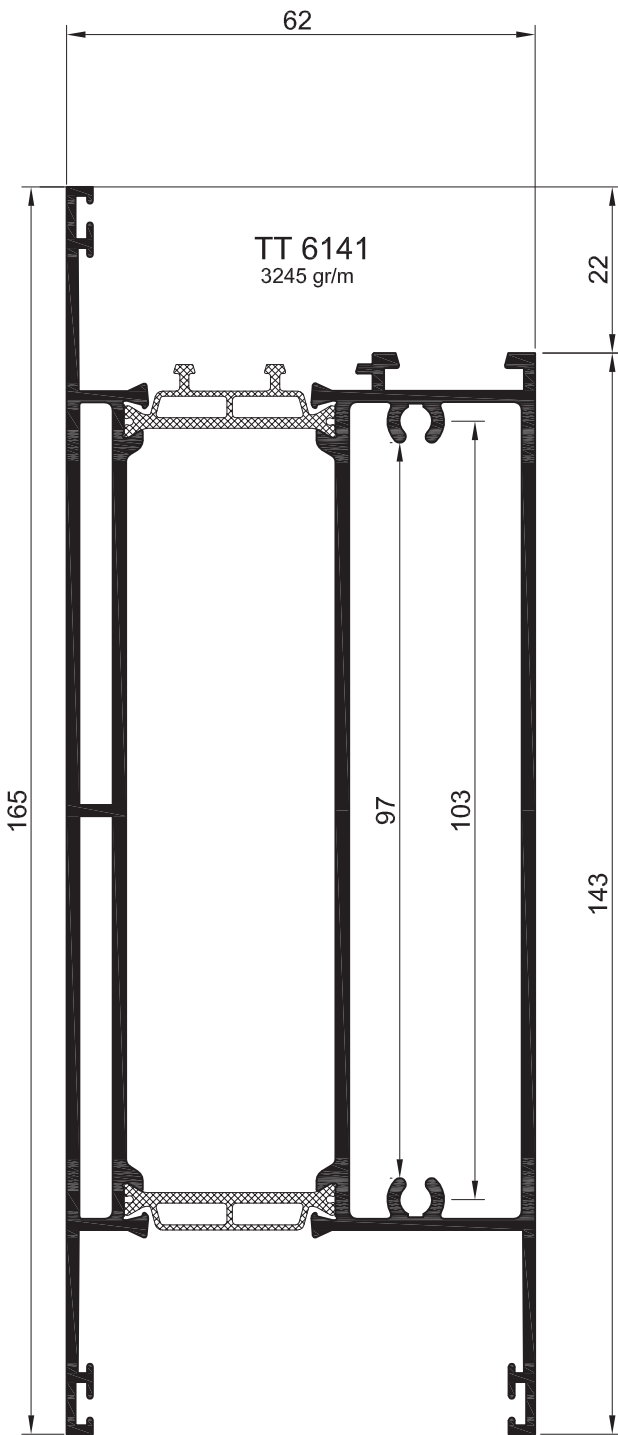

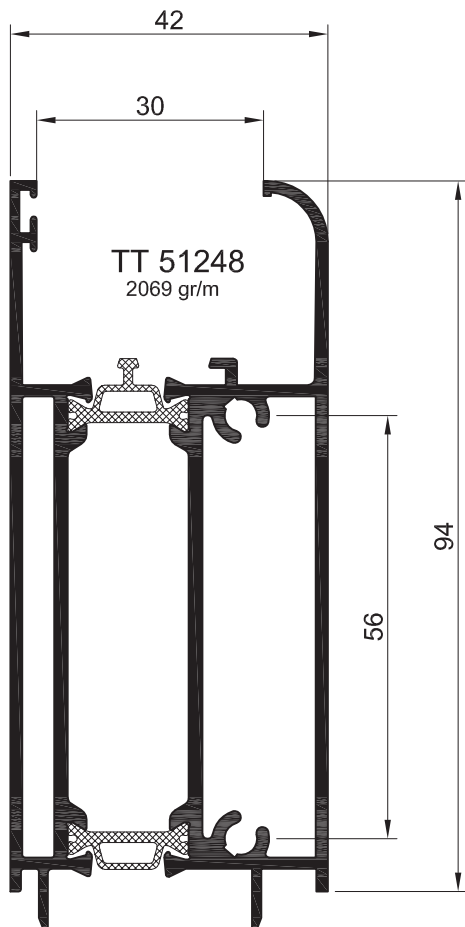
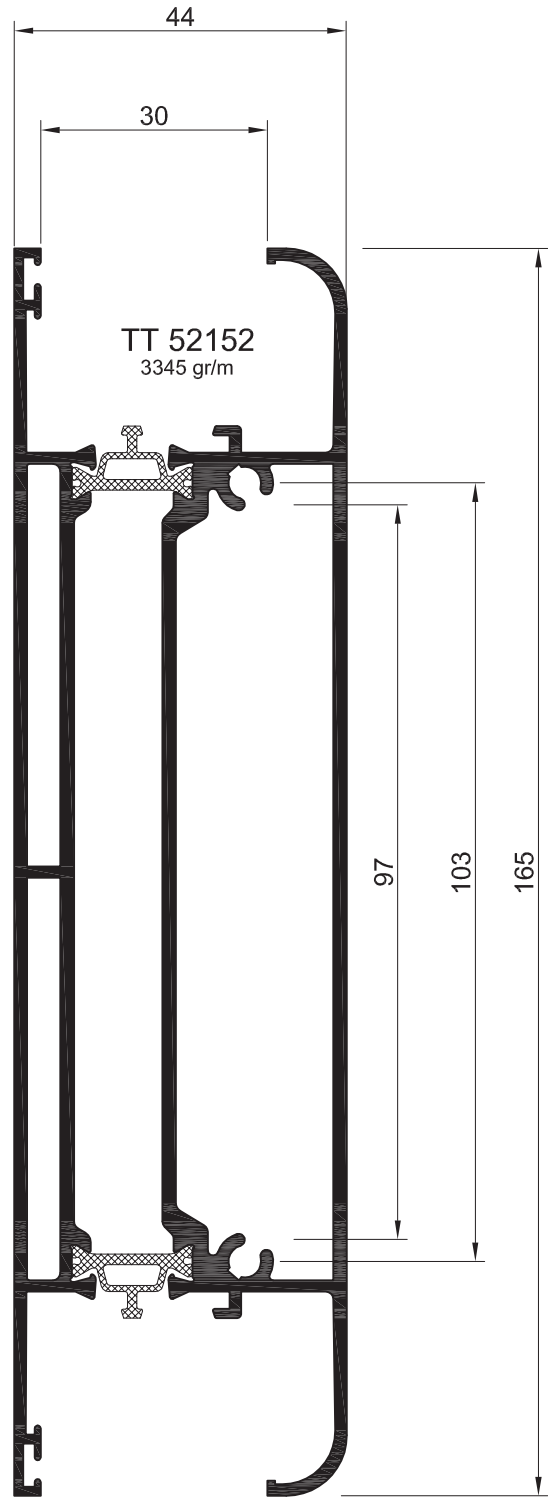
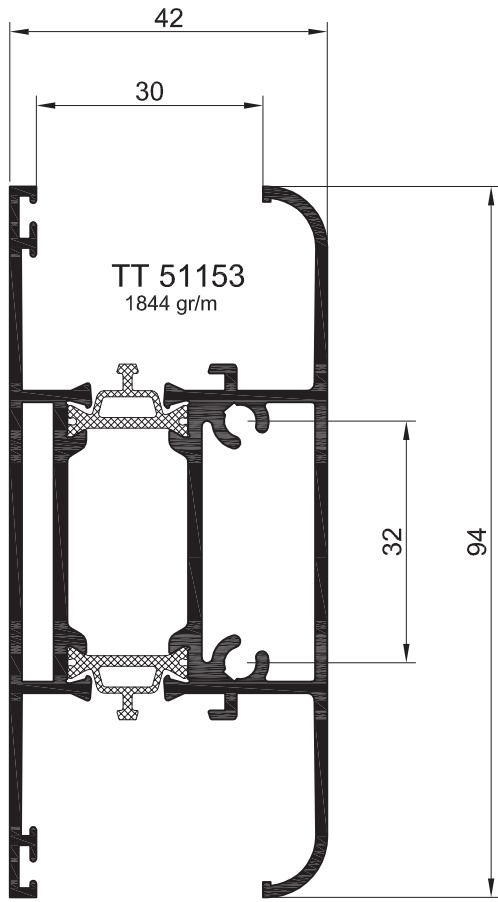

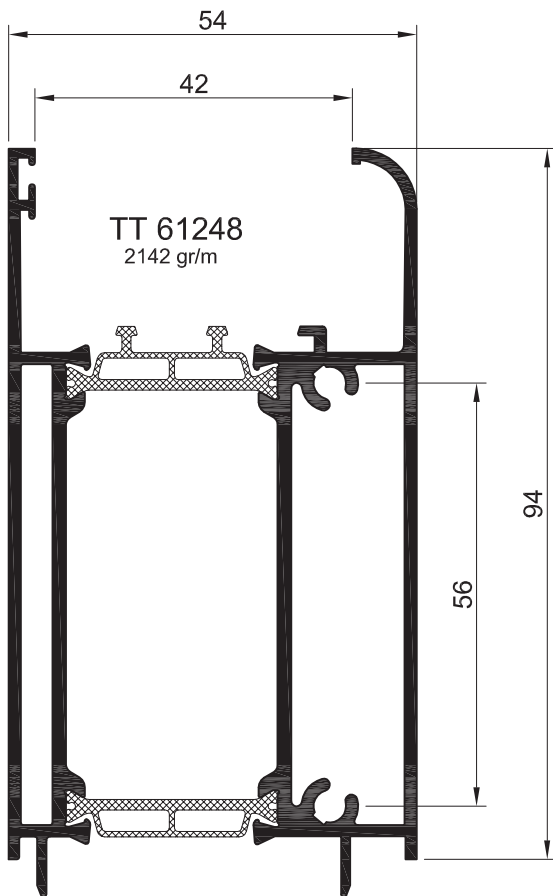
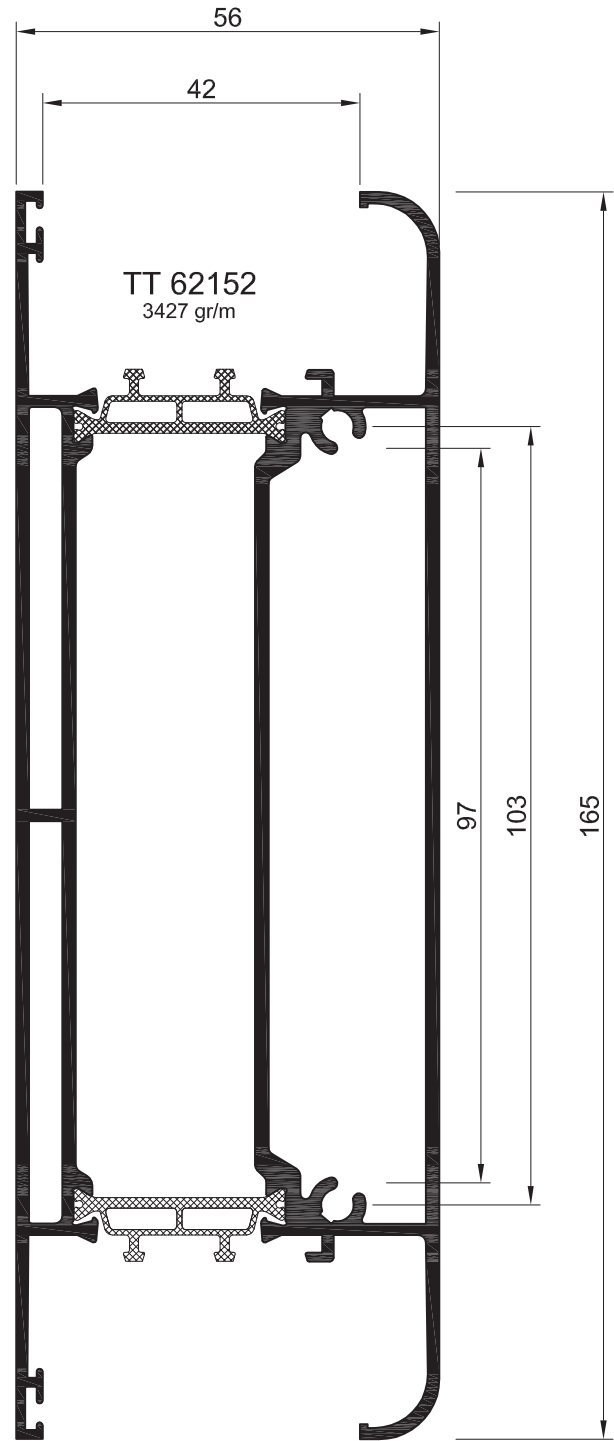
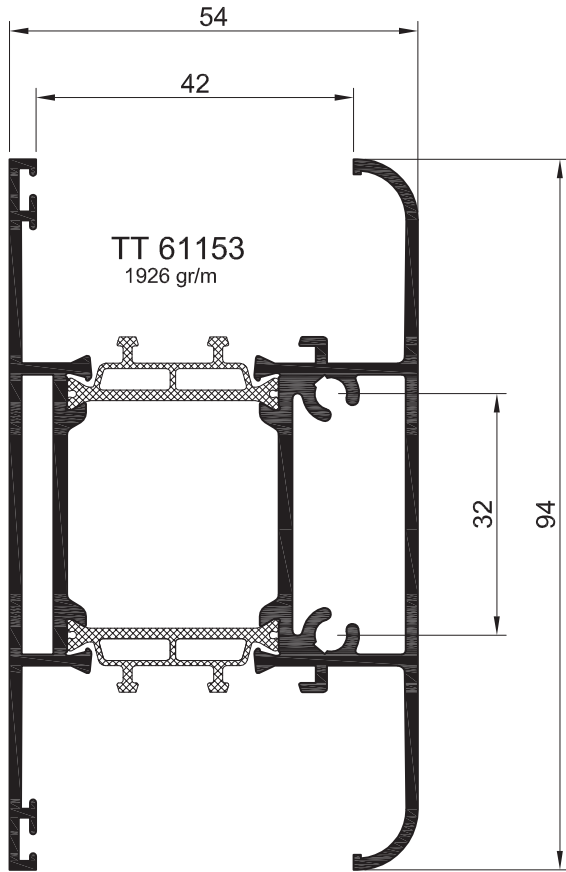

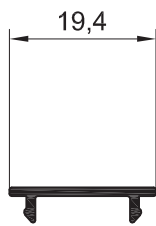
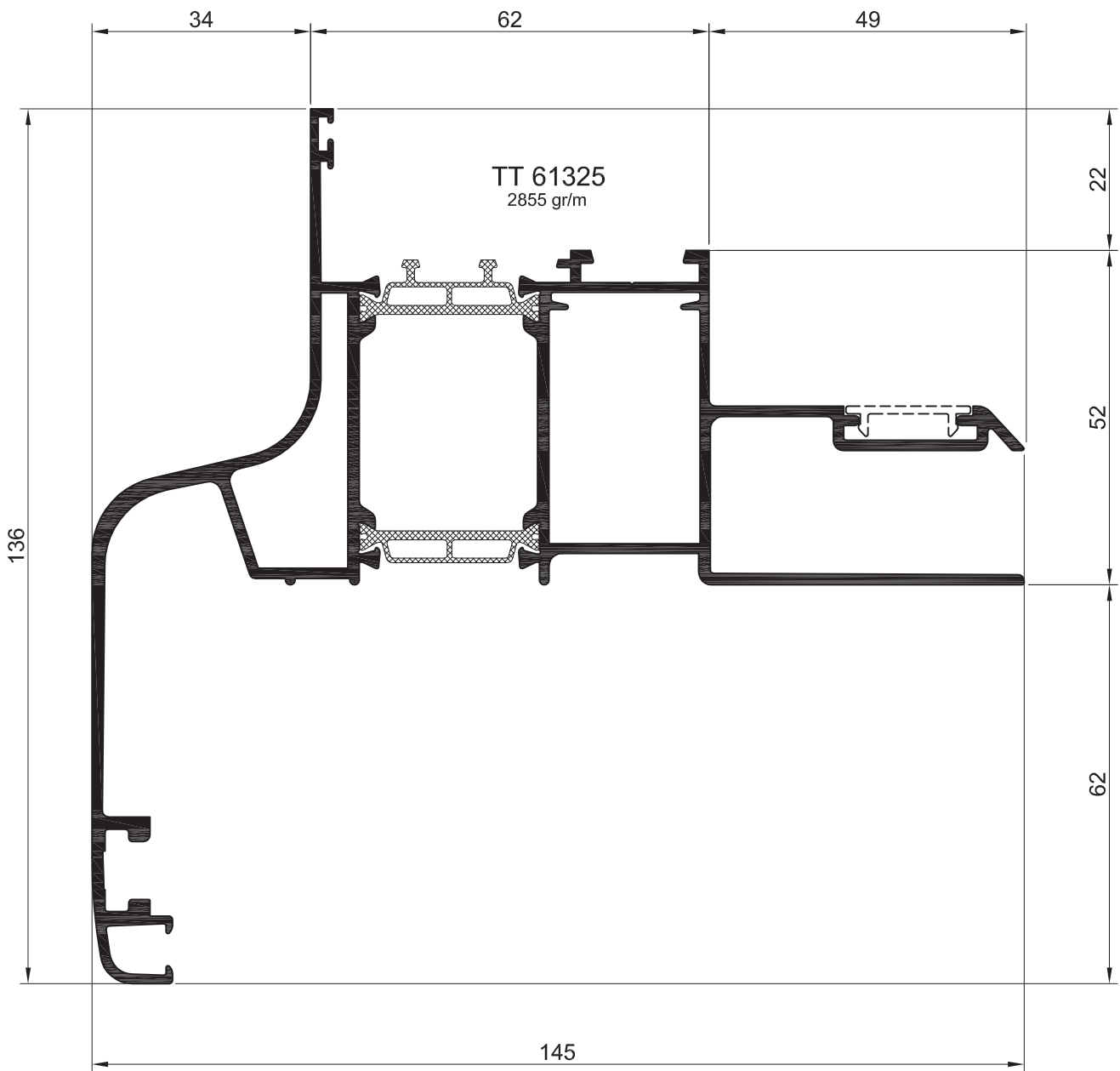

PL 20226
95 gr/m

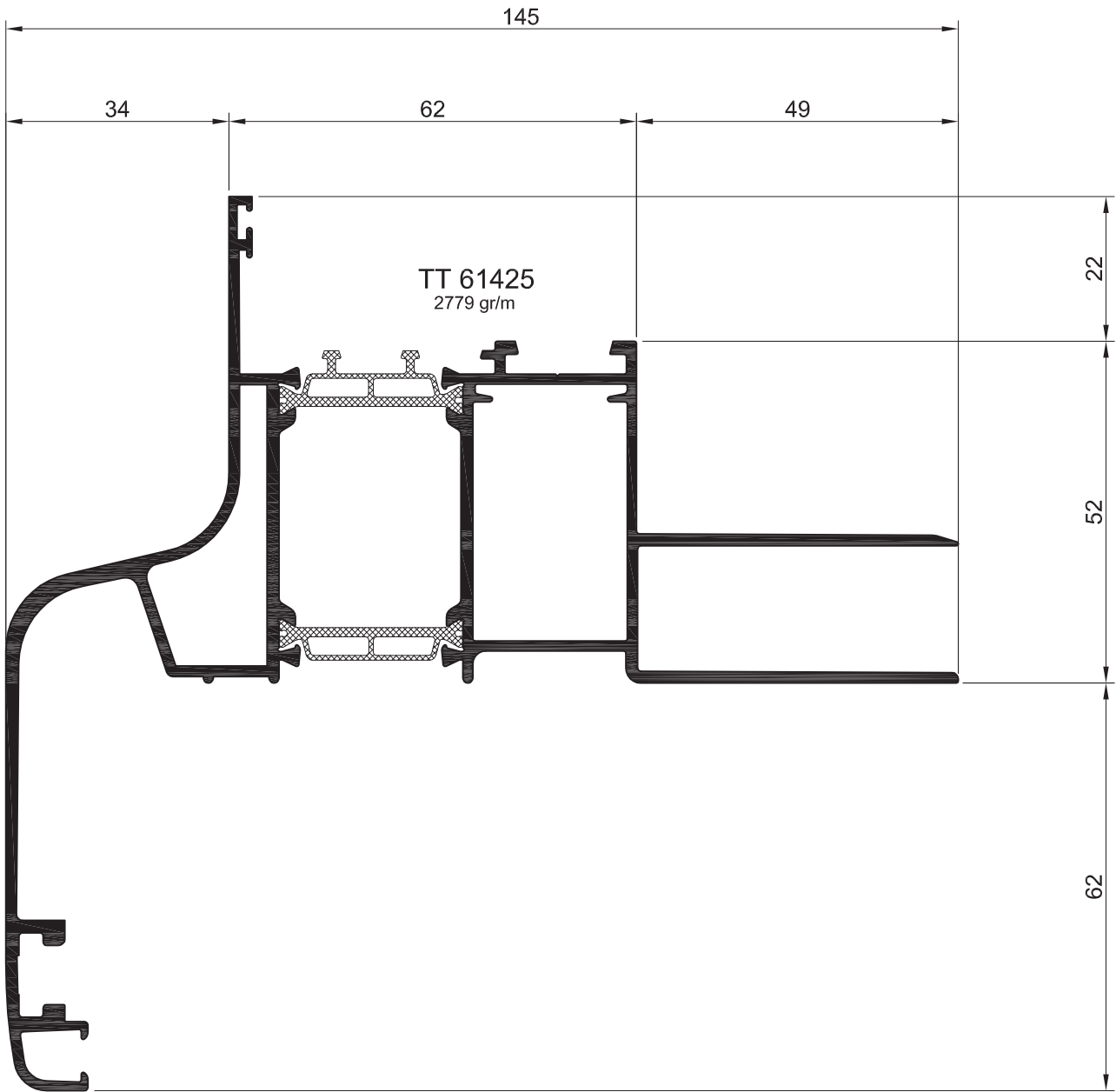

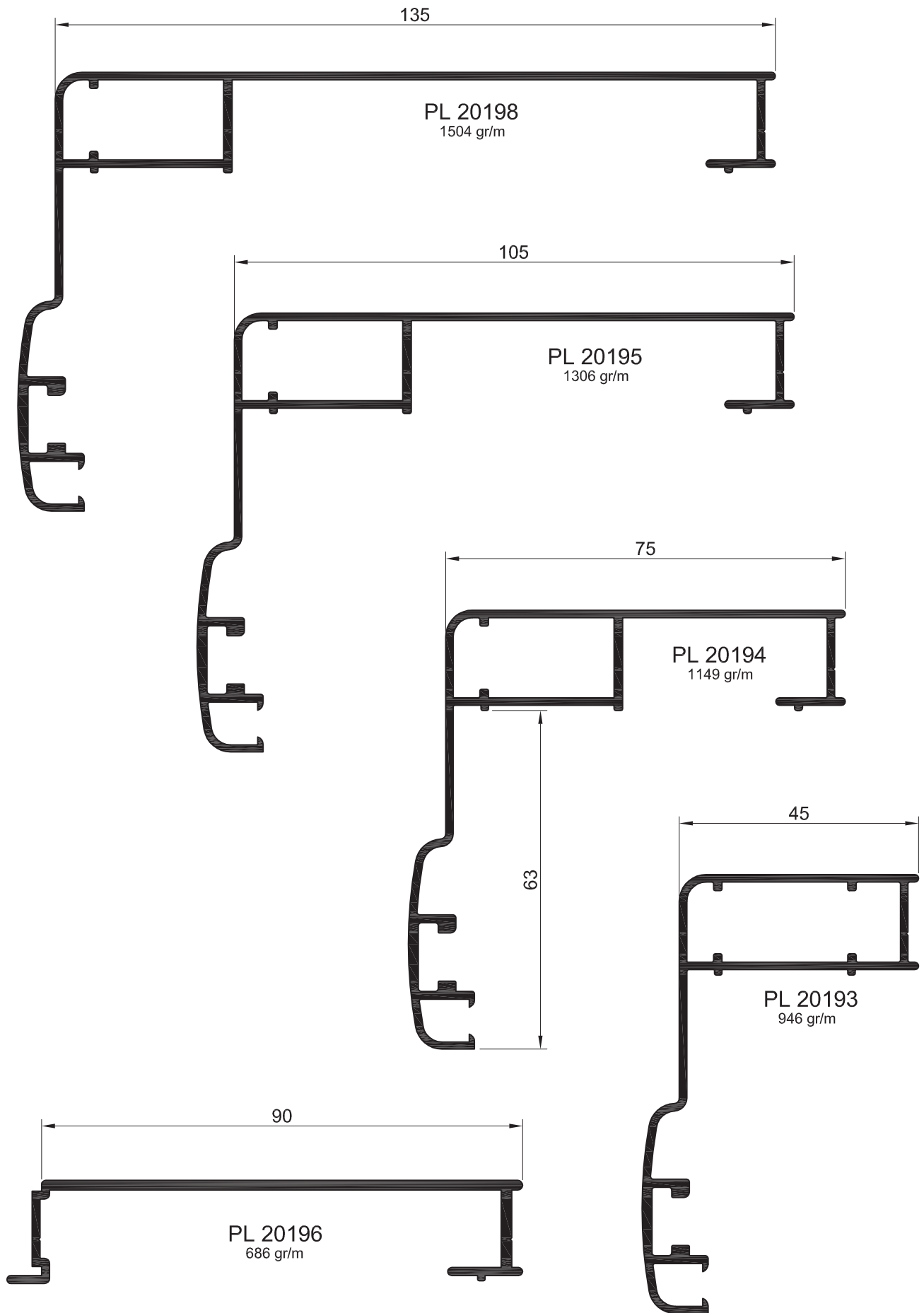

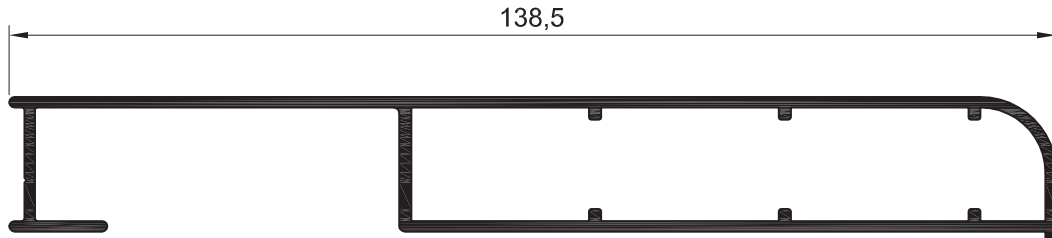

PL 20298
1472 gr/ml

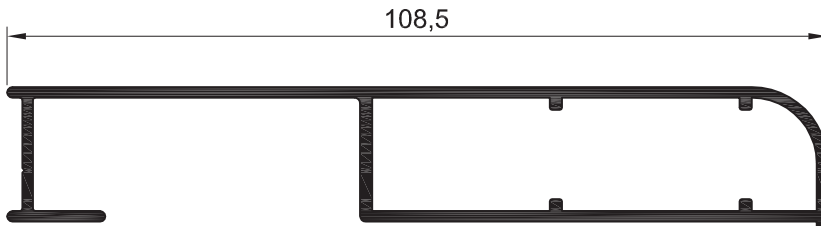

PL 20295
1236 gr/ml

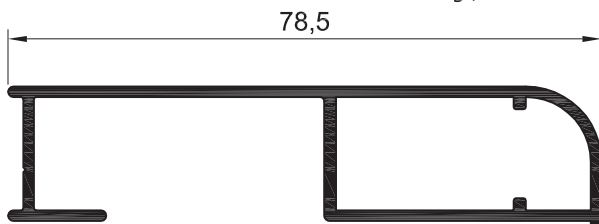

PL 20294
1022 gr/ml

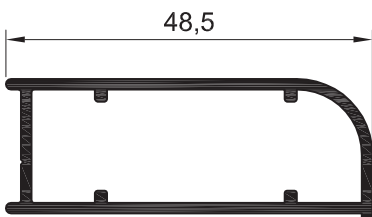

PL 20293
832 gr/ml



PL 20296
816 gr/ml

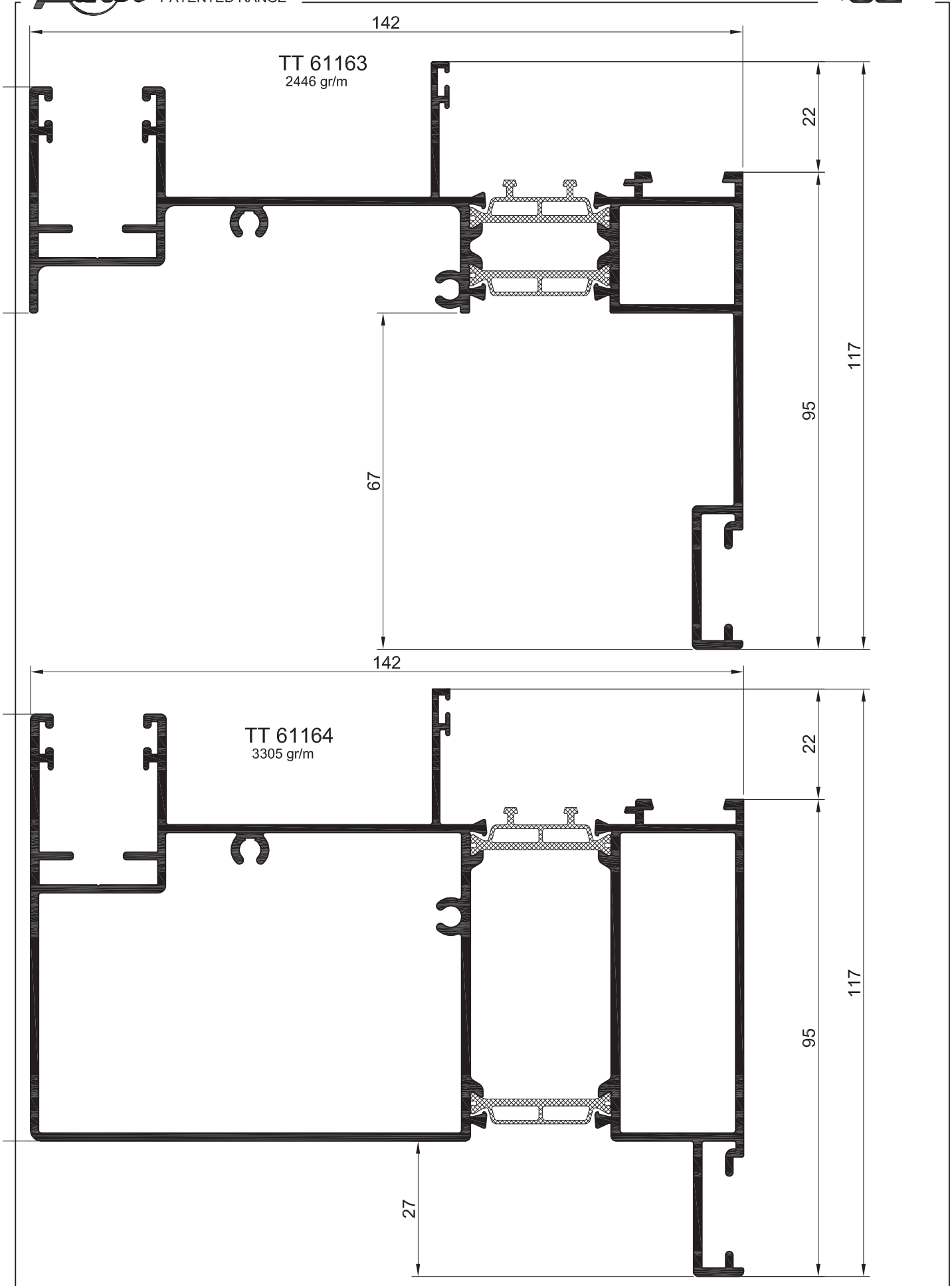

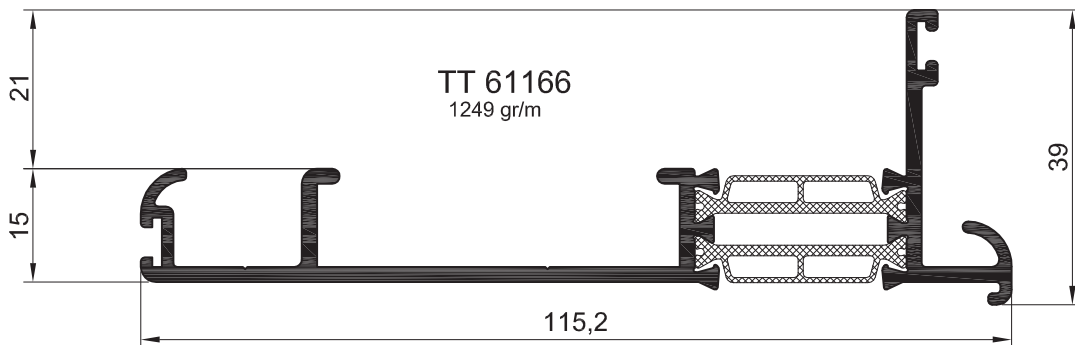
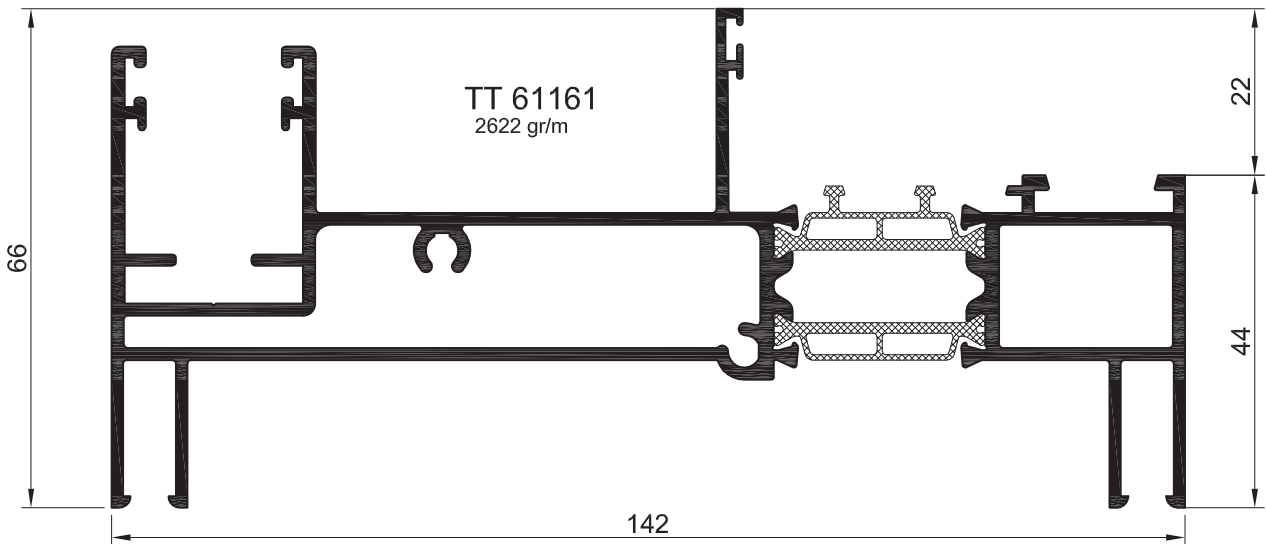
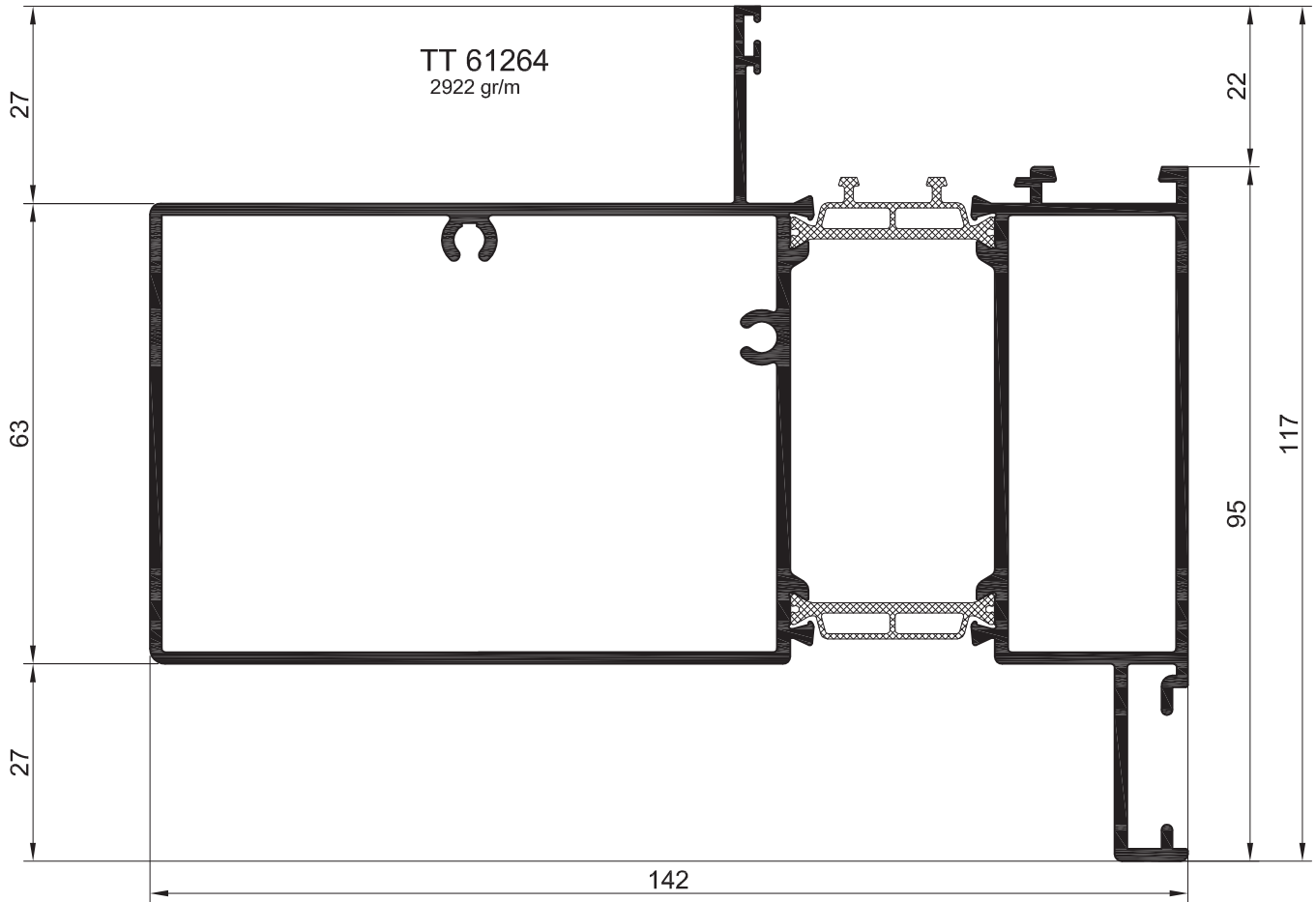

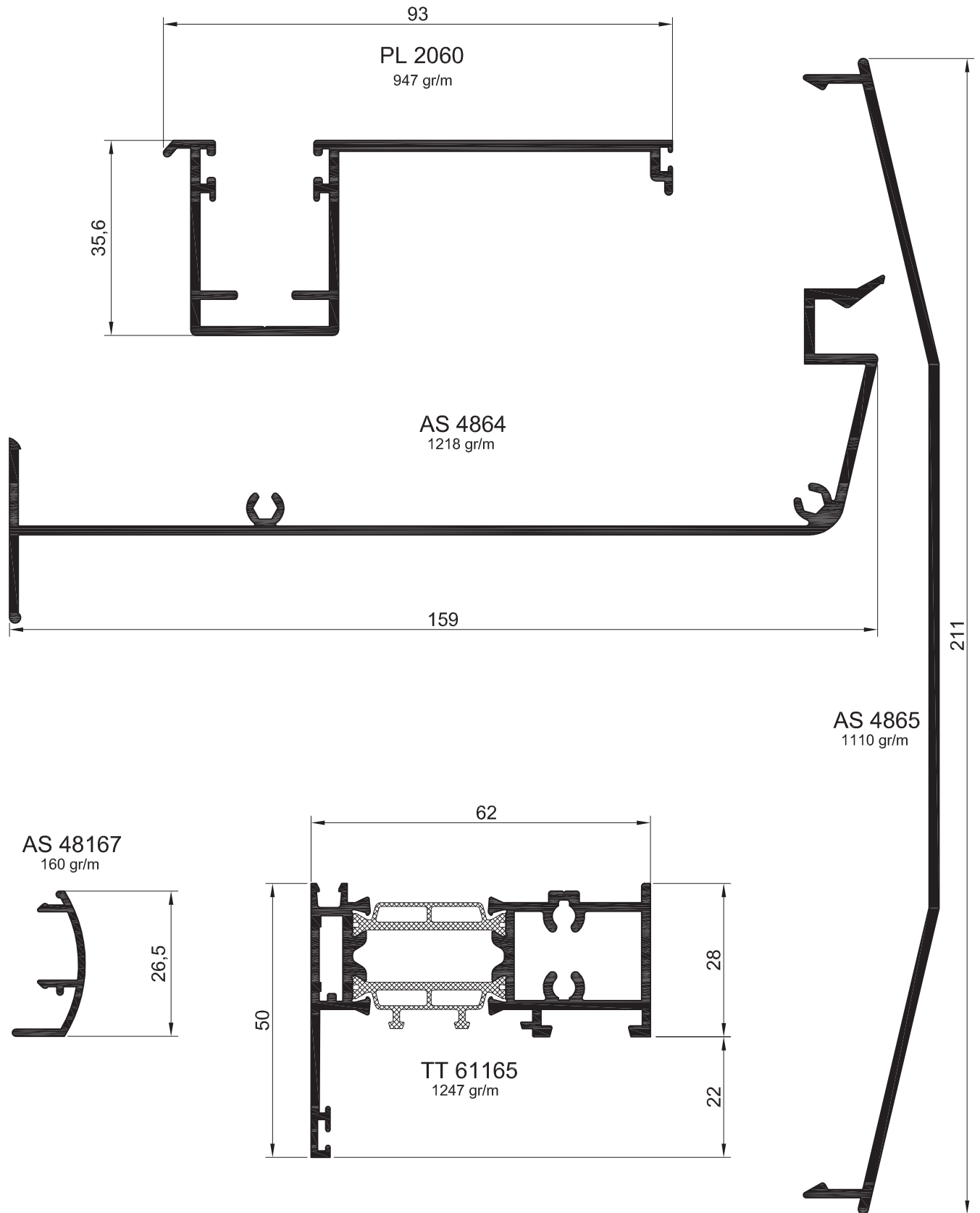

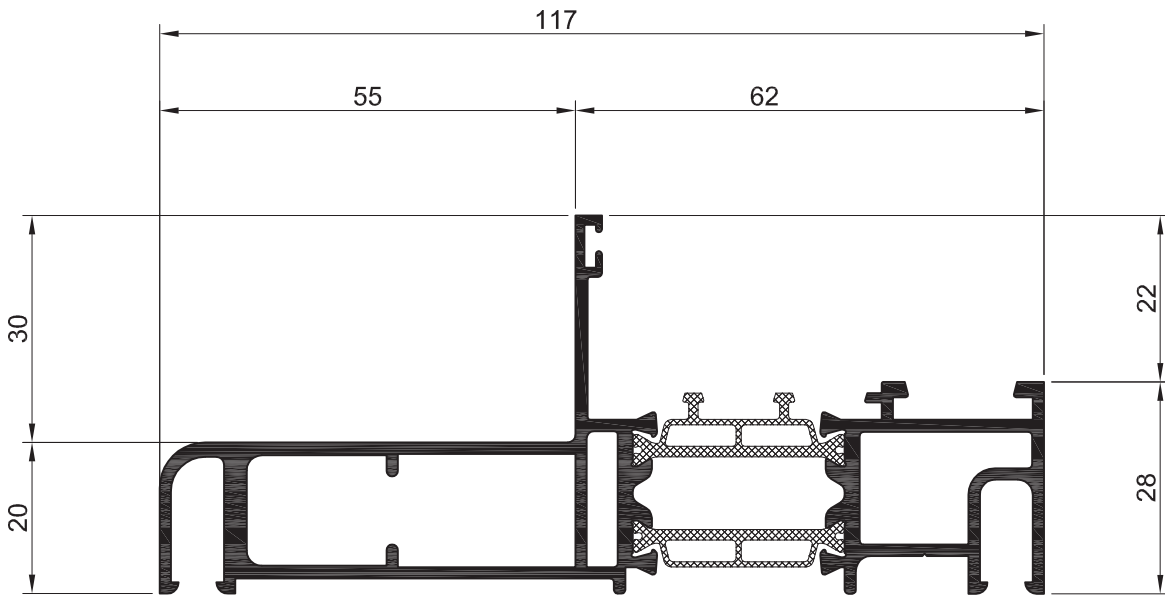

TT 6169
1899 gr/m

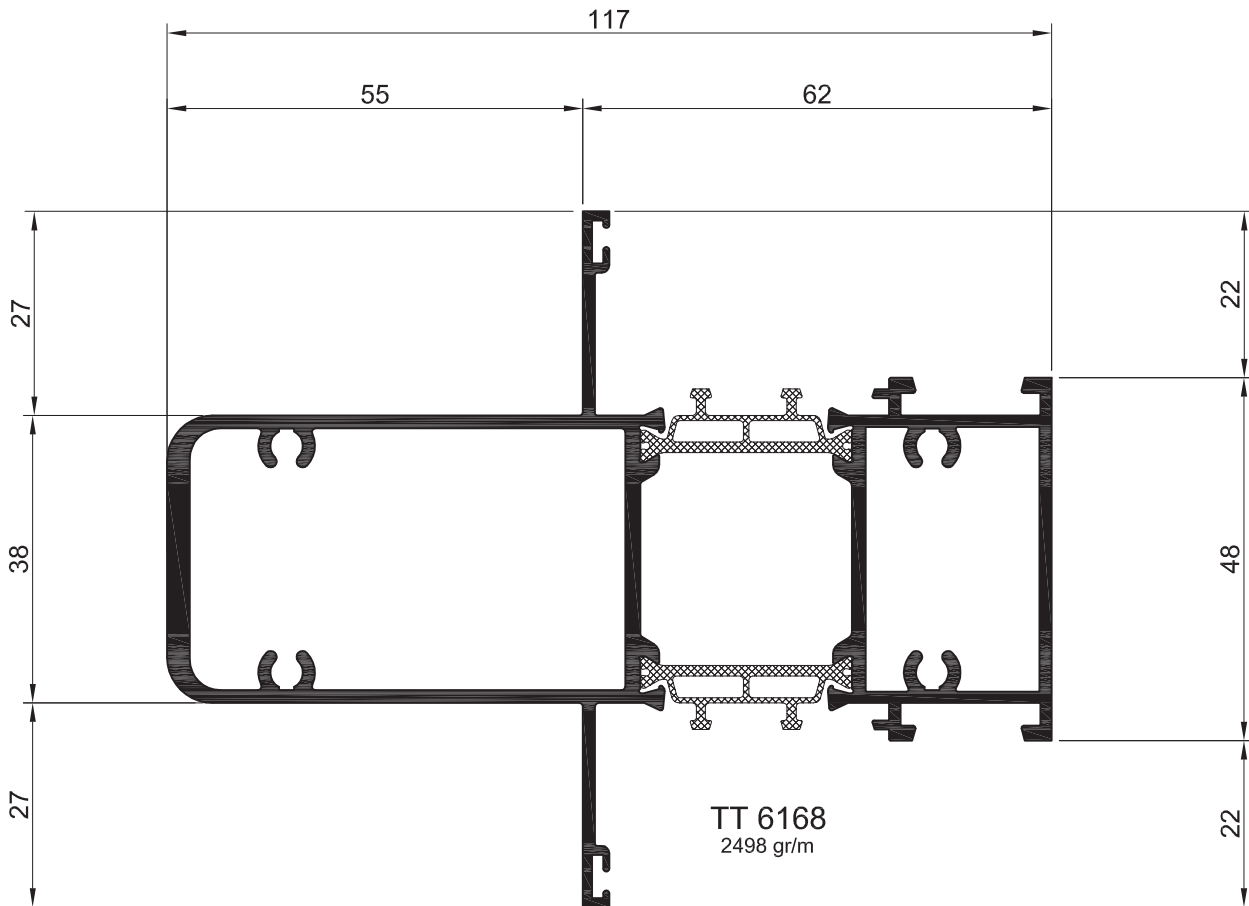

TT 6168
2498 gr/m

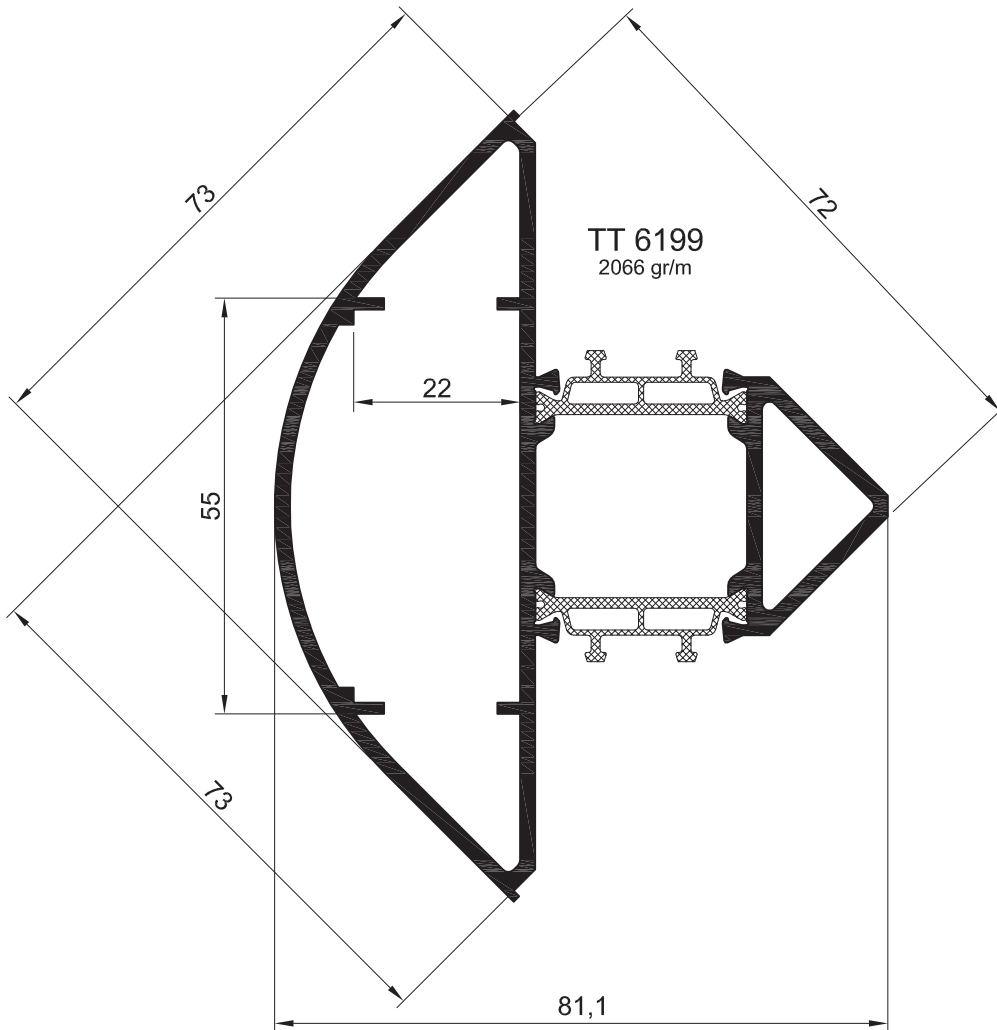
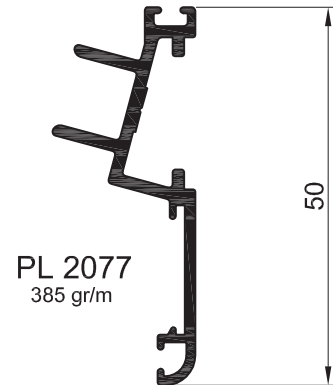
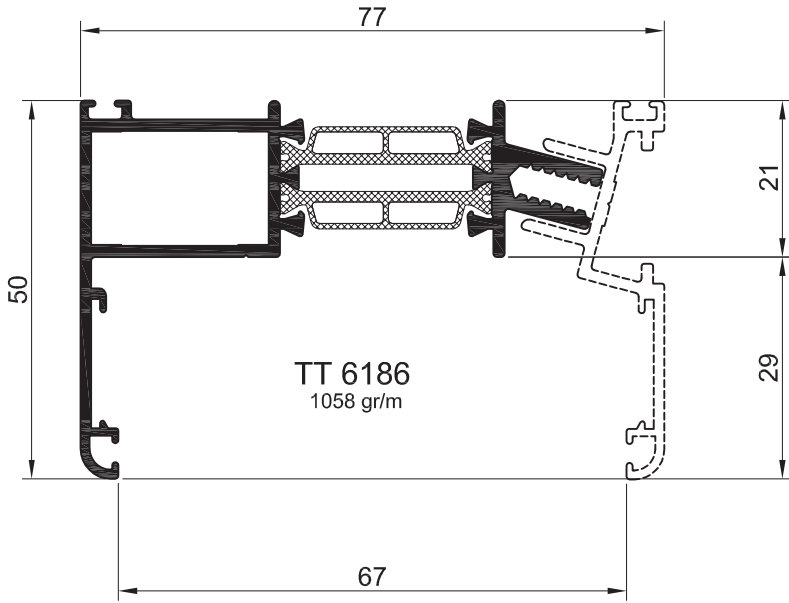

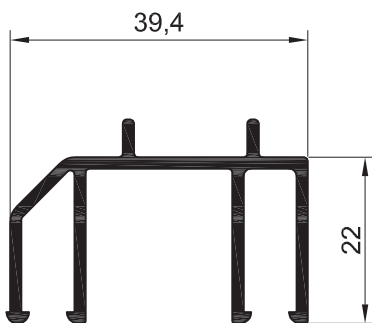
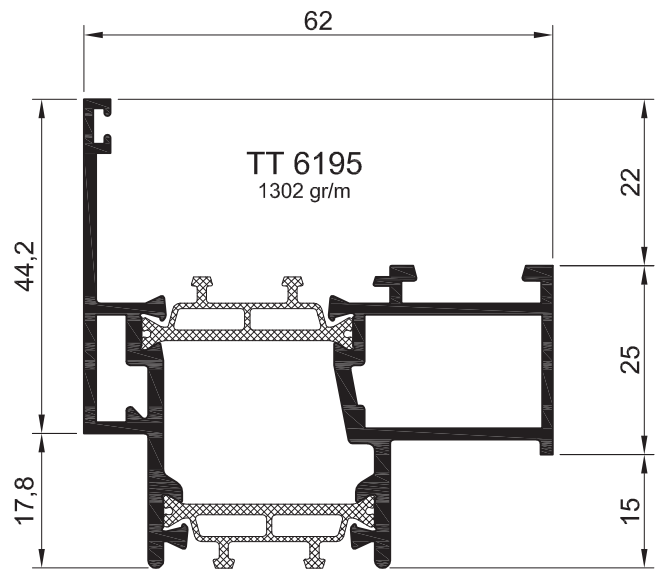
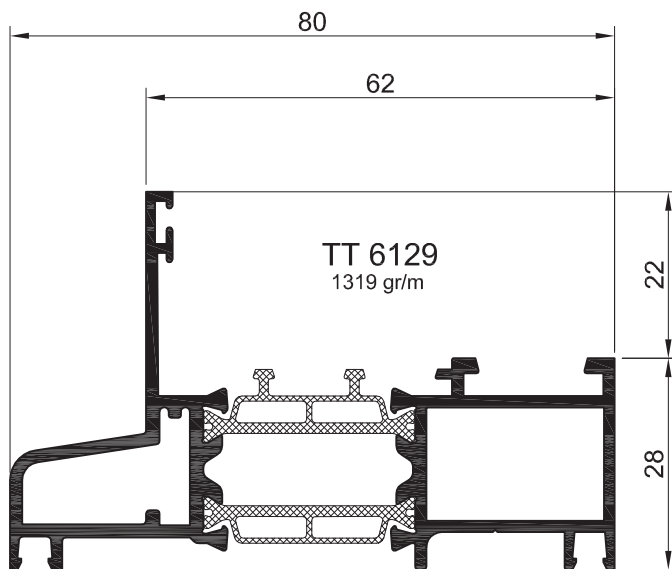
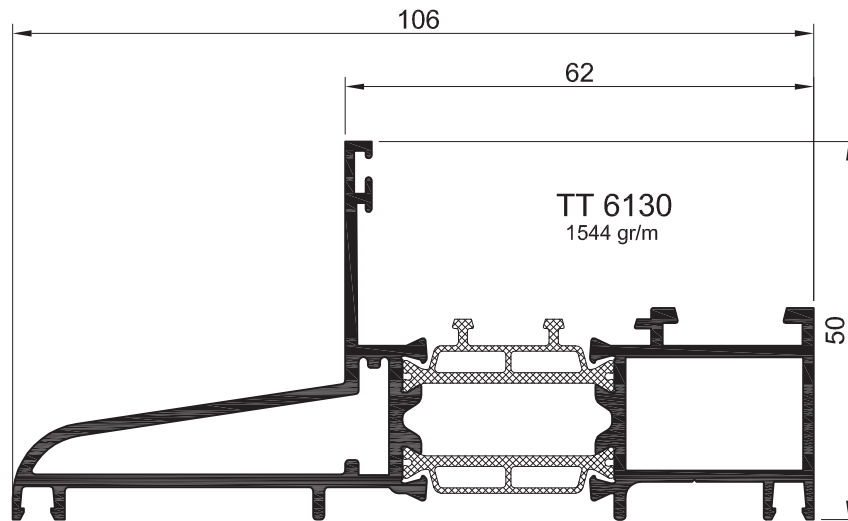

PL 2075
528 gr/m

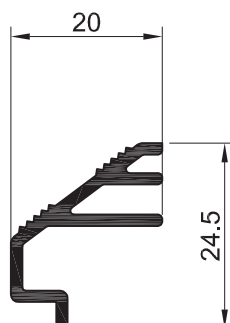

PL 20126
260 gr/m

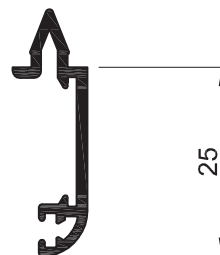

PL 2067
205 gr/m

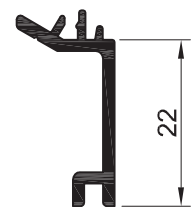

PL 20128
190 gr/m

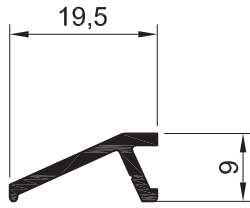

PL 20100
129 gr/m

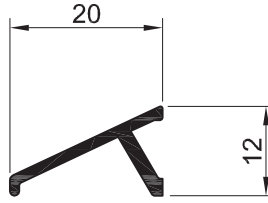

AS 1001R
127 gr/m

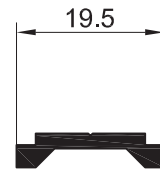

AS 1000
119 gr/m

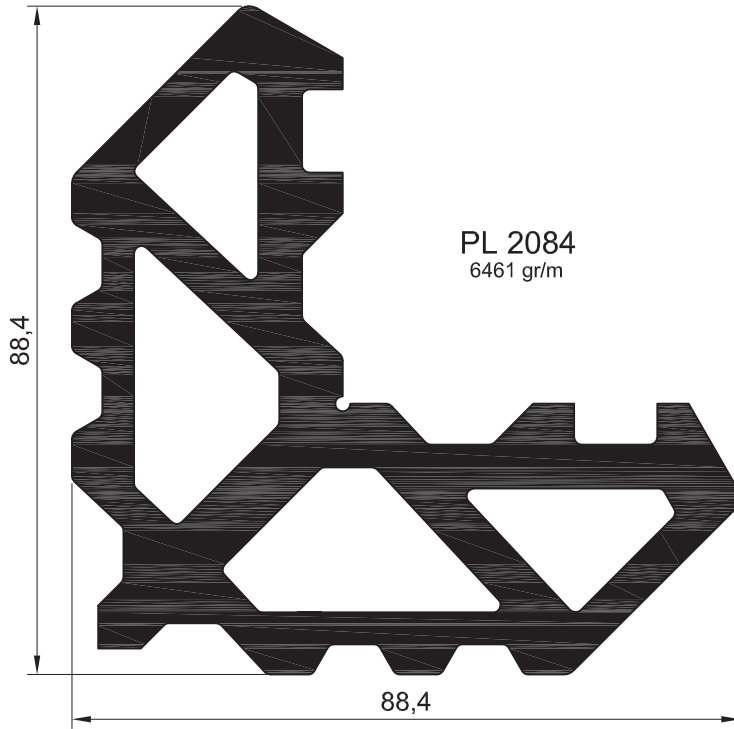

PL 2084
6461 gr/m

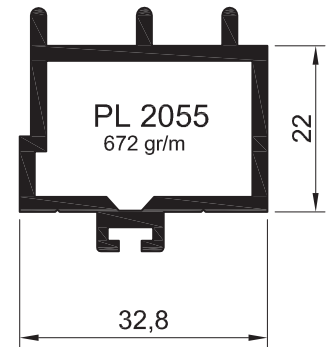

PL 2055
672 gr/m

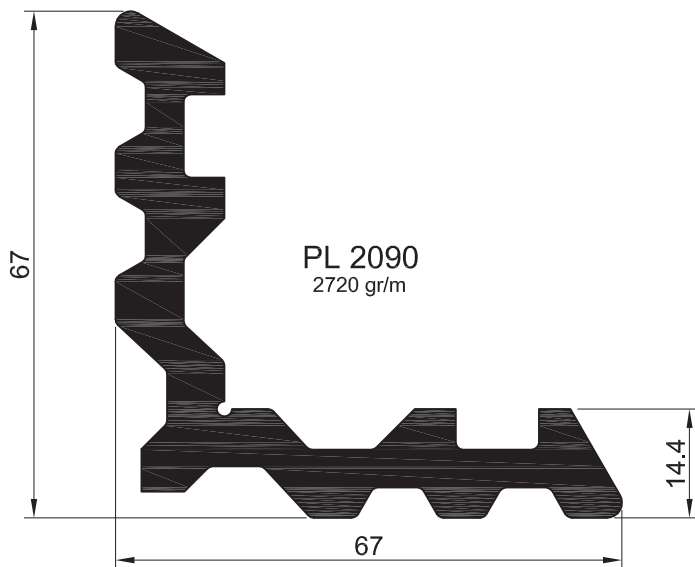

PL 2090
2720 gr/m

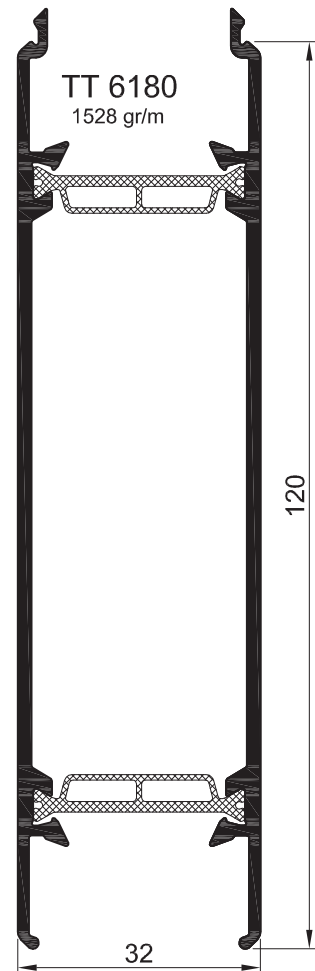

TT 6180
1528 gr/m

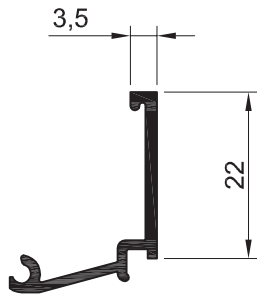

PL 1404
190 gr/m

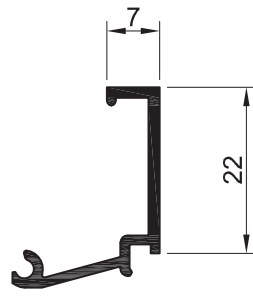

PL 1407
206 gr/m

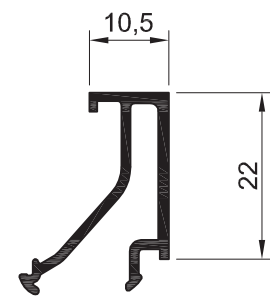

PL 1411
252 gr/m

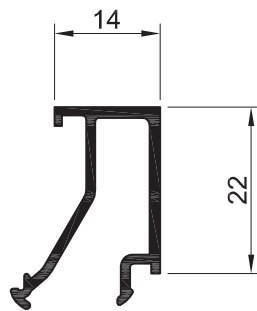

PL 1414
257 gr/m

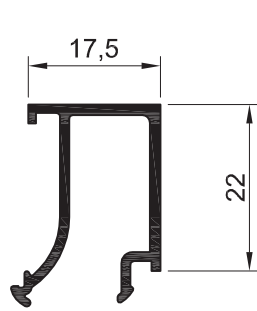

PL 1418
268 gr/m

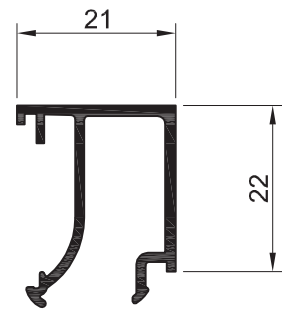

PL 1421
290 gr/m

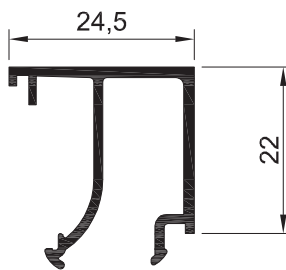

PL 1425
304 gr/m

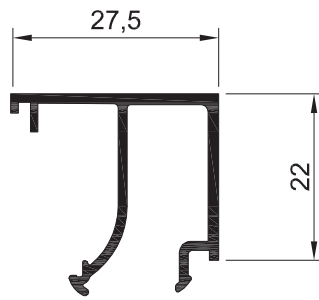

PL 1428
312 gr/m

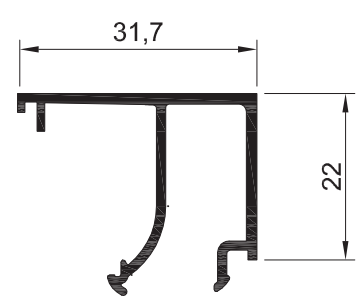

PL 1432
331 gr/m

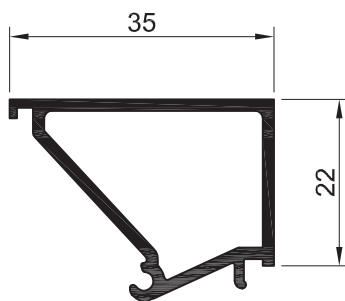

PL 1435 *
434 gr/m

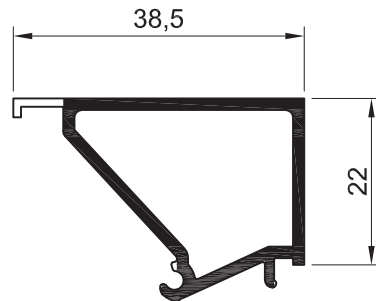

PL 1439 *
445 gr/m

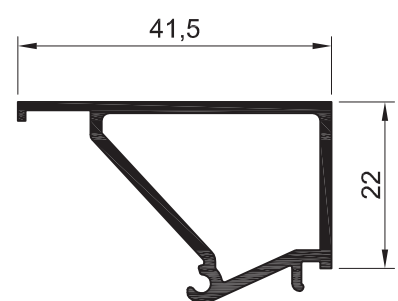

PL 1442 *
454 gr/m

* ALWAYS USE RUBBER STRIP ACP5027

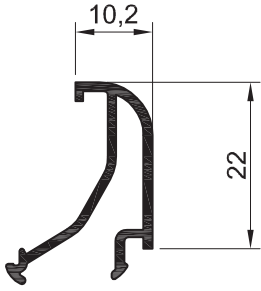

PL 1511
238 gr/m

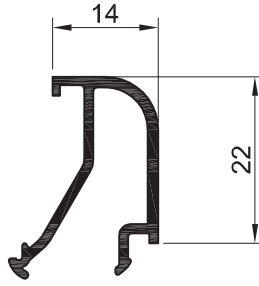

PL 1514
247 gr/m

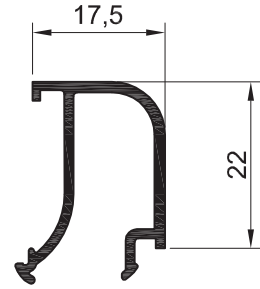

PL 1518
257 gr/m

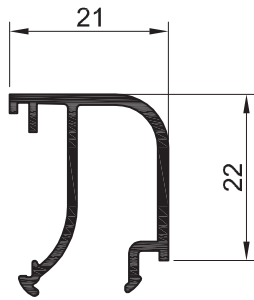

PL 1521
279 gr/m

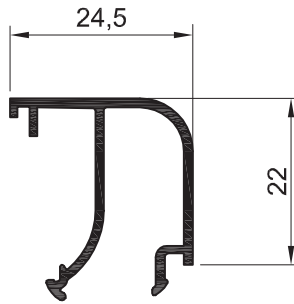

PL 1525
290 gr/m

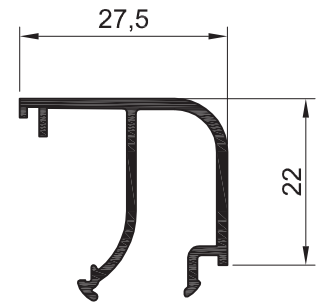

PL 1528
301 gr/m

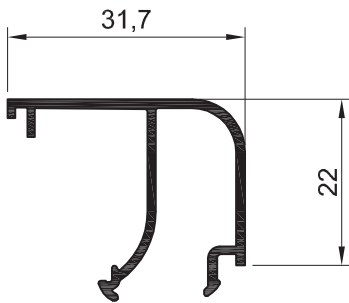

PL 1532
317 gr/m

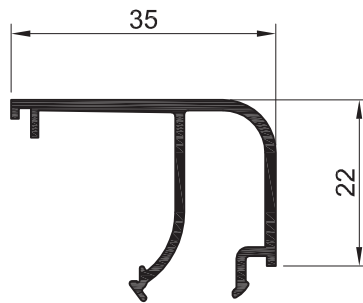

PL 1535
337 gr/m

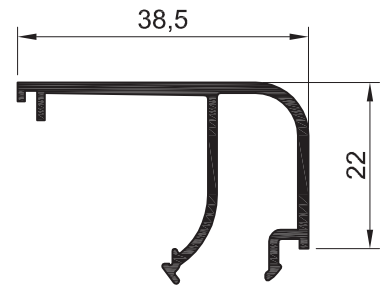

PL 1539
352 gr/m

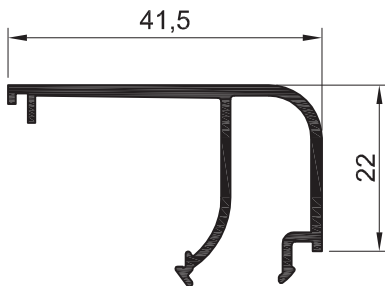

PL 1542
365 gr/m

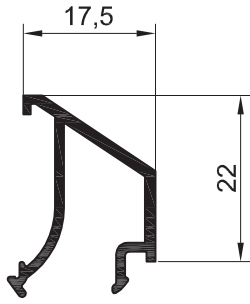

PL 1818
236 gr/m

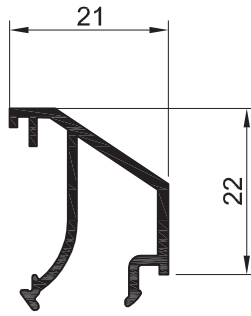

PL 1821
258 gr/m

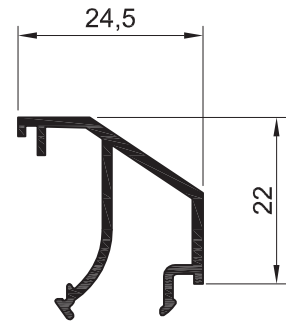

PL 1825
270 gr/m

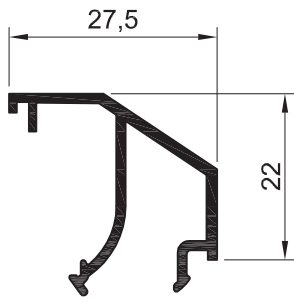

PL 1828
279 gr/m

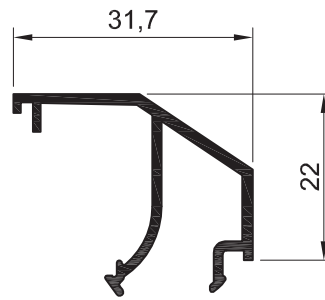

PL 1832
296 gr/m

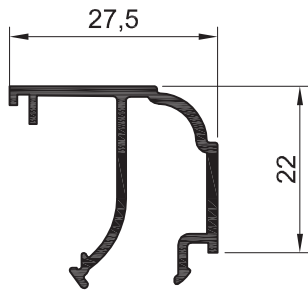



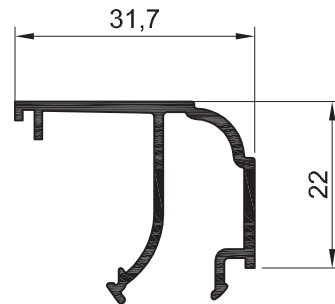

PL 1928
298 gr/m



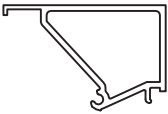
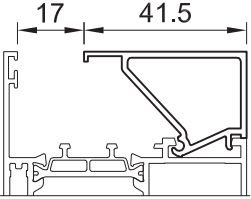
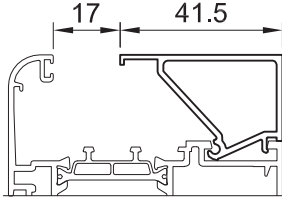
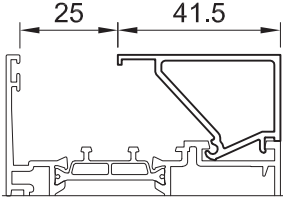
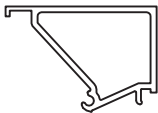
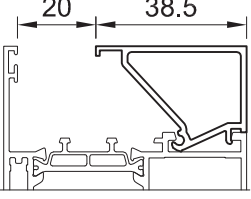
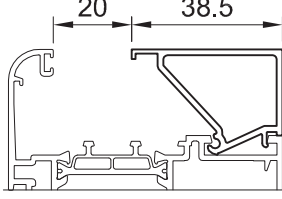
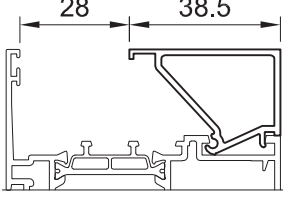
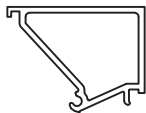
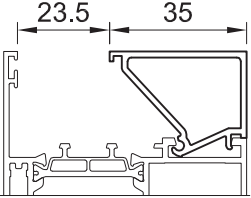
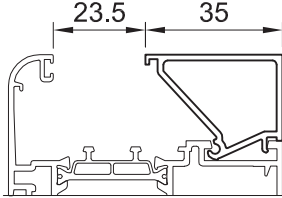
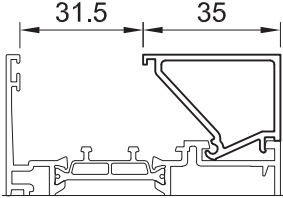
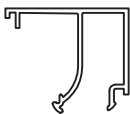
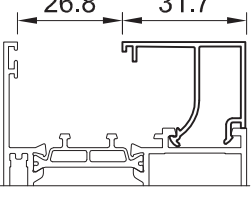
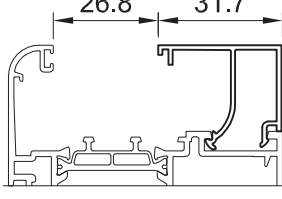
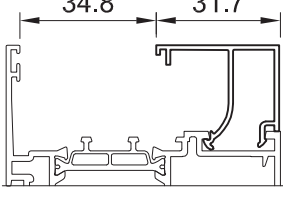
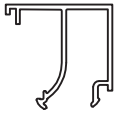
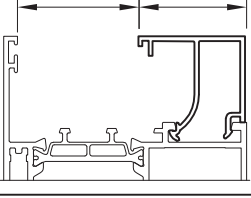
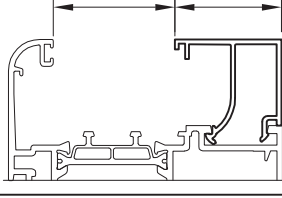
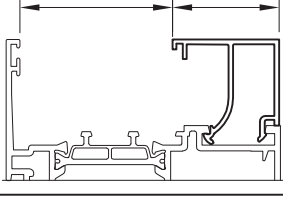
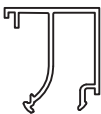
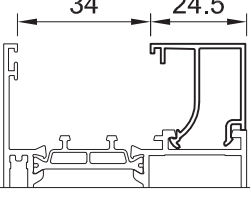
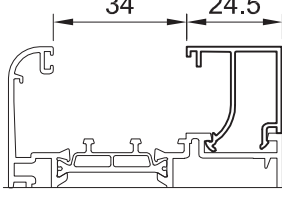
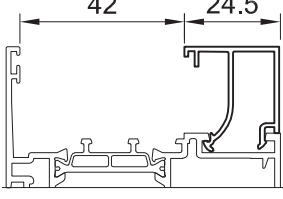

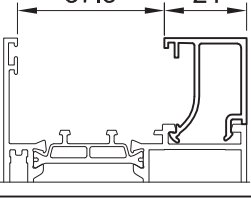
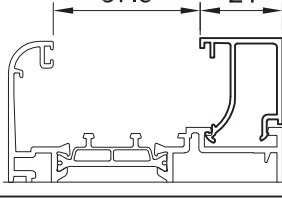
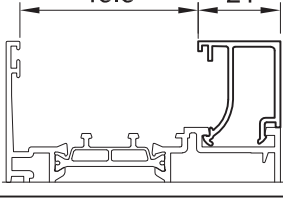
PL 1932
317 gr/m

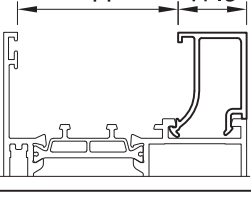
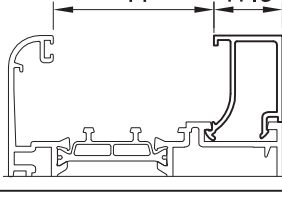
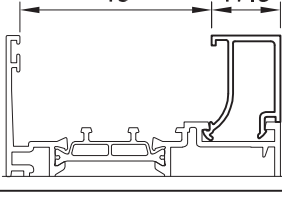



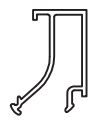
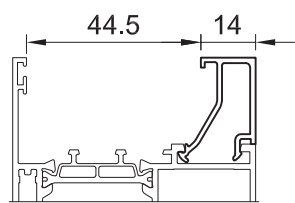
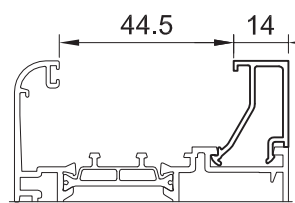
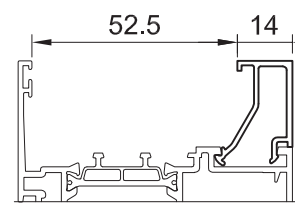

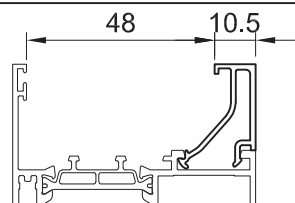
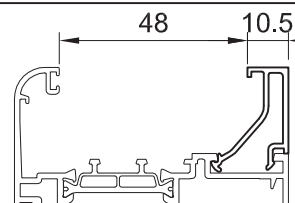
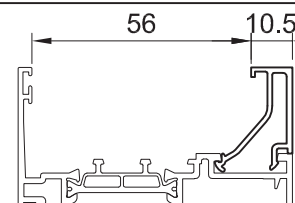
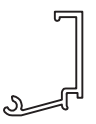
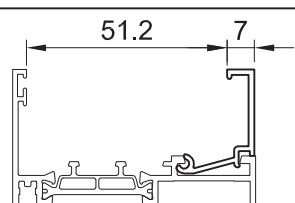
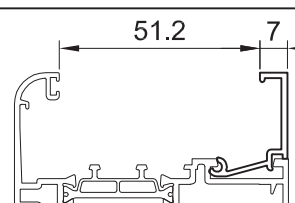
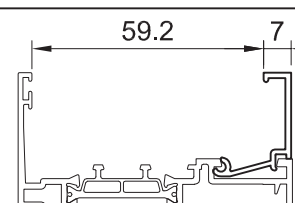
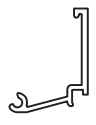
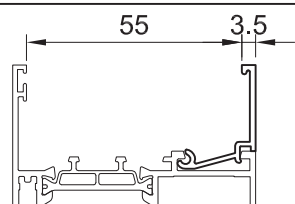
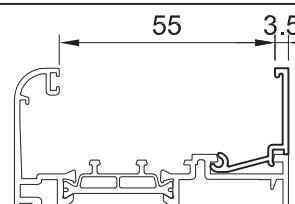
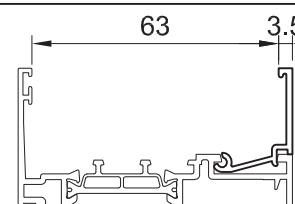
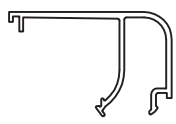
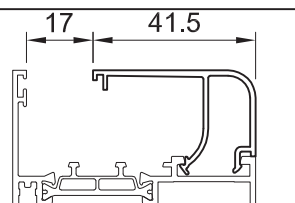
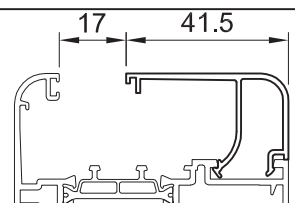
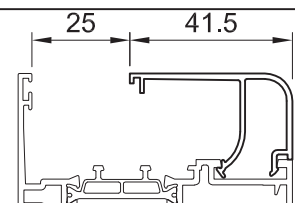
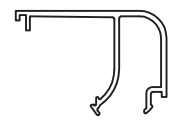
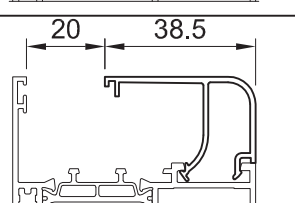
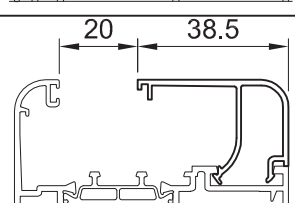
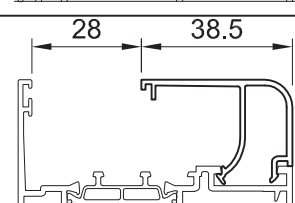
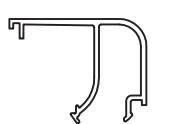
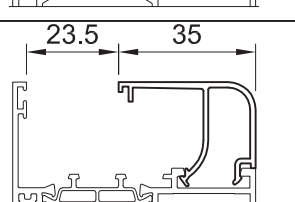
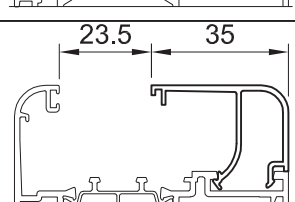
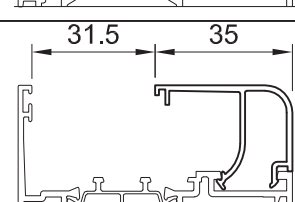
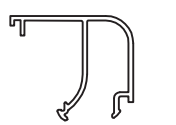
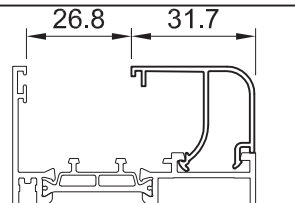
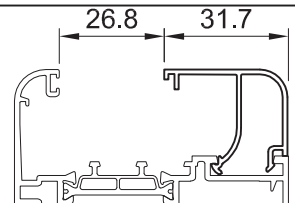
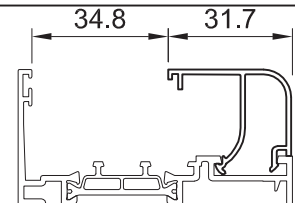
Glazing

Glazing bead	Frame TT 6102	Leaf TT 6112	Leaf TT 6111
 <p>PL 1442</p>			
 <p>PL 1439</p>			
 <p>PL 1435</p>			
 <p>PL 1432</p>			
 <p>PL 1428</p>			
 <p>PL 1425</p>			
 <p>PL 1421</p>			
 <p>PL 1418</p>			

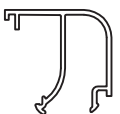
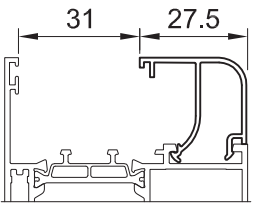
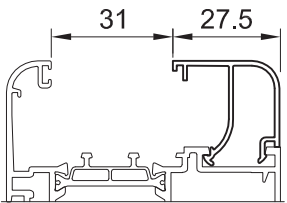
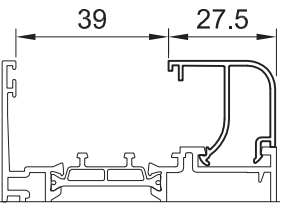
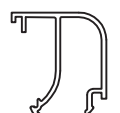
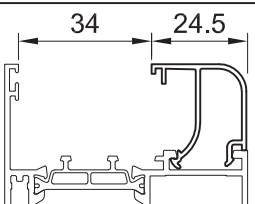
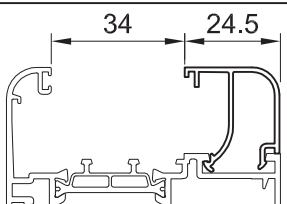
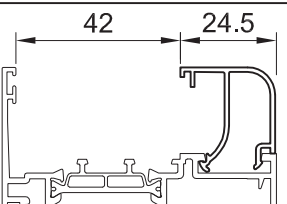
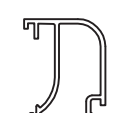
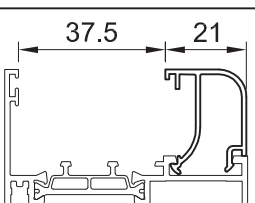
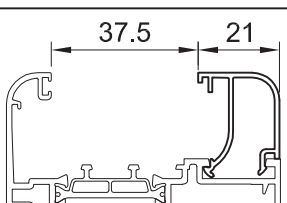
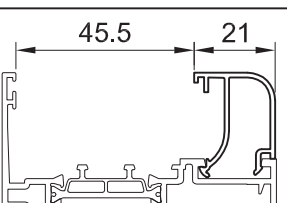
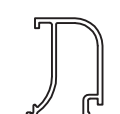
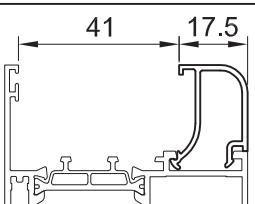
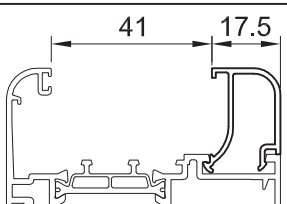
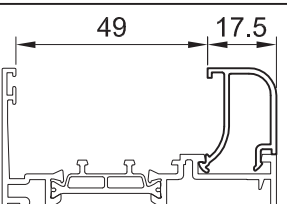
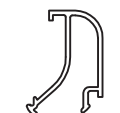
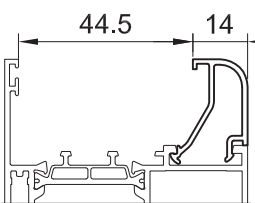
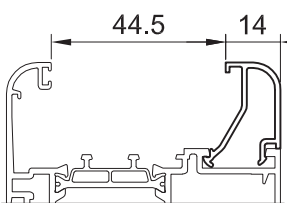
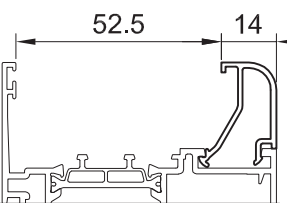

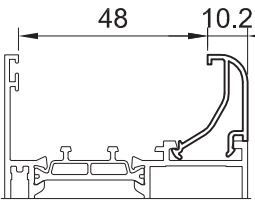
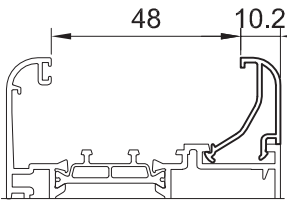
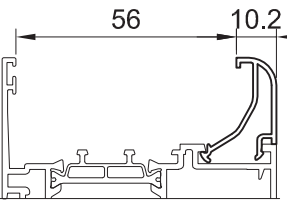

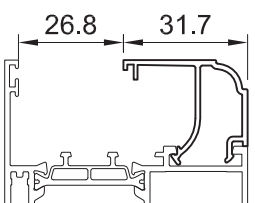
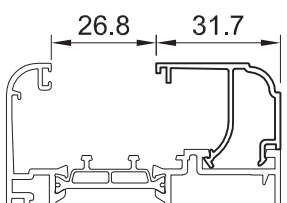
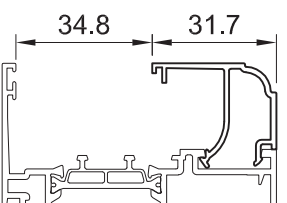

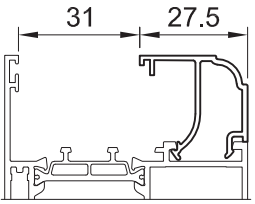
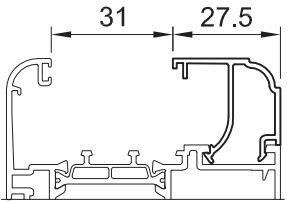
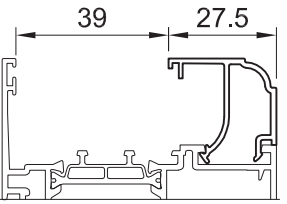

Glazing

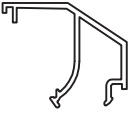
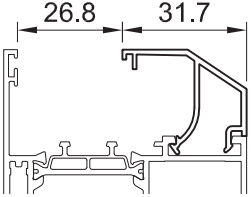
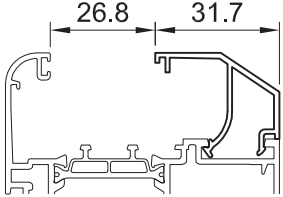
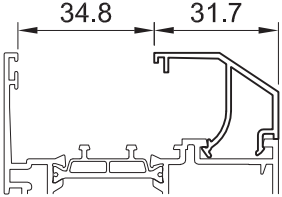
Glazing bead	Frame TT 6102	Leaf TT 6112	Leaf TT 6111
 PL 1414	 <p>44.5 14</p>	 <p>44.5 14</p>	 <p>52.5 14</p>
 PL 1411	 <p>48 10.5</p>	 <p>48 10.5</p>	 <p>56 10.5</p>
 PL 1407	 <p>51.2 7</p>	 <p>51.2 7</p>	 <p>59.2 7</p>
 PL 1404	 <p>55 3.5</p>	 <p>55 3.5</p>	 <p>63 3.5</p>
 PL 1542	 <p>17 41.5</p>	 <p>17 41.5</p>	 <p>25 41.5</p>
 PL 1539	 <p>20 38.5</p>	 <p>20 38.5</p>	 <p>28 38.5</p>
 PL 1535	 <p>23.5 35</p>	 <p>23.5 35</p>	 <p>31.5 35</p>
 PL 1532	 <p>26.8 31.7</p>	 <p>26.8 31.7</p>	 <p>34.8 31.7</p>

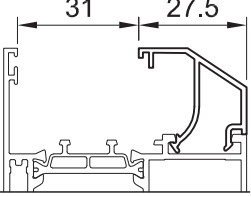
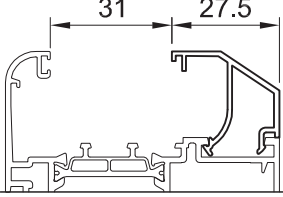
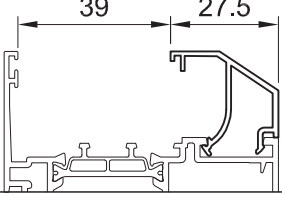

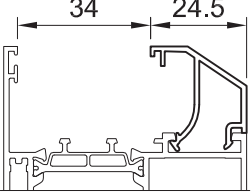
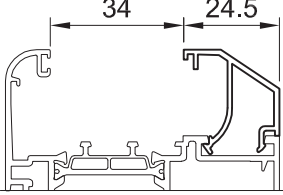
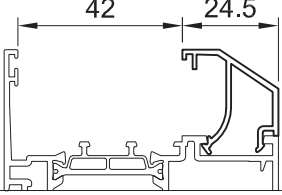

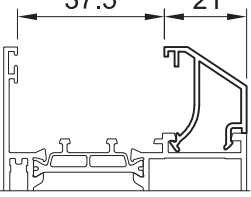
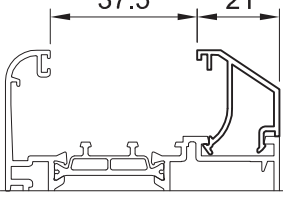
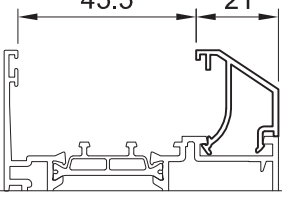

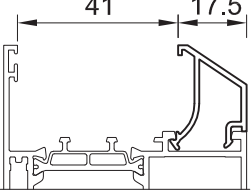
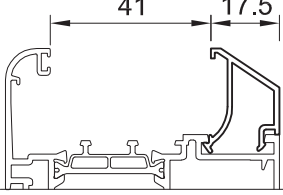
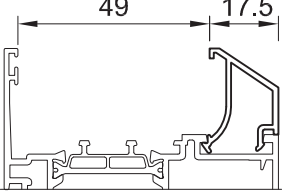









Glazing

Glazing bead	Frame TT 6102	Leaf TT 6112	Leaf TT 6111
 PL 1528	 31 27.5	 31 27.5	 39 27.5
 PL 1525	 34 24.5	 34 24.5	 42 24.5
 PL 1521	 37.5 21	 37.5 21	 45.5 21
 PL 1518	 41 17.5	 41 17.5	 49 17.5
 PL 1514	 44.5 14	 44.5 14	 52.5 14
 PL 1511	 48 10.2	 48 10.2	 56 10.2
 PL 1932	 26.8 31.7	 26.8 31.7	 34.8 31.7
 PL 1928	 31 27.5	 31 27.5	 39 27.5

Glazing

Glazing bead	Frame TT 6102	Leaf TT 6112	Leaf TT 6111
 PL 1832	 26.8 31.7	 26.8 31.7	 34.8 31.7
 PL 1828	 31 27.5	 31 27.5	 39 27.5
 PL 1825	 34 24.5	 34 24.5	 42 24.5
 PL 1821	 37.5 21	 37.5 21	 45.5 21
 PL 1818	 41 17.5	 41 17.5	 49 17.5

List of gaskets

	AGG 3000 Rebate gasket for industrial shed frames and wall profiles of internal doors metres packed 100		AGP 3105 Internal glass gasket in PVC 5 mm metres packed 360
	AGP 3002 Internal glass gasket in EPDM 2 mm metres packed 150		AGP 3106 Internal glass gasket in PVC 6 mm metres packed 250
	AGP 3003 Internal glass gasket in EPDM 3 mm metres packed 100		AGP 3107 Internal glass gasket in PVC 7 mm metres packed 200
	AGP 3005 Internal glass gasket in EPDM 5 mm metres packed 100		AGP 3108 Internal glass gasket in PVC 8 mm metres packed 160
	AGP 3092 Joint for ribbon windows metres packed 65		AGP 3110 Internal glass gasket in PVC 10 mm metres packed 140
	AGP 3101 Internal glass gasket in PVC 1 mm metres packed 1000		AGP 3123 Pre-cut EPDM internal glass gasket, 2/3 mm. Allows 90° fold without cutting metres packed 200
	AGP 3102 Internal glass gasket in PVC 2 mm metres packed 600		AGP 3145 Pre-cut EPDM internal glass gasket, 4/5 mm. Allows 90° fold without cutting metres packed 200
	AGP 3103 Internal glass gasket in PVC 3 mm metres packed 500		AGP 3167 Pre-cut EPDM internal glass gasket, 6/7 mm. Allows 90° fold without cutting metres packed 150
	AGP 3104 Internal glass gasket in PVC 4 mm metres packed 500		

	AGP 4000 EPDM rebate gasket metres packed 400
	AGP 4002 Wall-frame perimetrical insulation gasket metres packed 200
	AGP 4003 Rebate gasket with rigid base in elaprene metres packed 800
	AGP 4004 Rebate gasket in co-extruded EPDM metres packed 300
	AGP 4005 Rebate gasket for central connection profile on the semi-fixed side for double rebate version metres packed 200
	AGP 4006 Rebate gasket for central connection profile on the semi-fixed side for open joint version metres packed 200
	AGP 4011 Underglass EPE thermal insulation gasket, mm 8x30 metres packed 10
	AGP 4013 EPDM external glass gasket, 2.5mm metres packed 200
	AGP 4014 EPDM external glass gasket, 4mm metres packed 200

	AGP 4031 Underglass EPE thermal insulation gasket, mm 11x30 metres packed 100
	AGP 4099 Perimetrical insulation gasket frame - counter-frame metres packed 50
	AGP 4103 Internal glass gasket in EPDM 2.5/3.5 mm for sound and thermal insulation metres packed 100
	AGP 4106 Internal glass gasket in EPDM 4/6 mm for sound and thermal insulation metres packed 80
	AGP 4113 External glass gasket in co-extruded EPDM/FOAM 2.5 mm for sound and thermal insulation metres packed 100
	AGP 4123 EPDM external glass gasket, 2.5mm Lip sealing strip for applying silicone sealant. Guarantees greater hermetic sealing metres packed 150
	AGP 4501R Open joint fin metres packed 90

	<p>AGP 4502</p> <p>Fin for low sill</p> <p>metres packed 65</p>
	<p>AGP 4807</p> <p>Under door brush strip 4.8 X 7mm</p> <p>metres packed 100</p>
	<p>AGP 4885R</p> <p>Vulcanised corner 40X40 for AGP 4501R fin</p> <p>pieces packed 100</p>
	<p>AGP 4886</p> <p>Vulcanised corner 40X40 for AGP 4502 fin</p> <p>pieces packed 250</p>
	<p>ACP 5058</p> <p>Gasket fitting roller</p> <p>pieces packed 1</p>
	<p>AGP 5806</p> <p>Brush strip 5.8 X 6mm for single-unit profiles</p> <p>metres packed 100</p>
	<p>AGP 6272</p> <p>Standard fin gasket replacing the AGP 4501R+AGP 6501 combination</p> <p>metres packed 50</p>



	<p>AGP 6280</p> <p>Leaf frames and sliding frames junction gasket</p> <p>metres packed 300</p>
	<p>AGP 6285</p> <p>Vulcanised corner 50X50 for AGP 6272 and AGP 7272</p> <p>pieces packed 384</p>
	<p>AGP 6501</p> <p>Supplementary gasket to fin AGP 4501R</p> <p>metres packed 80</p>
	<p>AGP 7202</p> <p>Under-door gasket</p> <p>metres packed 100</p>
	<p>AGP 7272</p> <p>Standard fin gasket in co-extruded EPDM</p> <p>metres packed 25</p>
	<p>SG 0601EN</p> <p>Sound gasket, thickness 1 mm</p> <p>metres packed 100</p>

List of general accessories

	AC 2028 Water drainage cap pairs packed 200
	AC 2077 glass adjustment kit for beadless glazing leaves kit packed 100
	AC 2099 Hole-closing cap ø 11.5mm pieces packed 1000
	ACP 5014 Round glazing bead angle pieces packed 160
	ACP 5027 Glazing bead locking rubber strip for PL1404 and PL1407 and tubulars pieces packed 100
	ACP 5035 Nylon wall spacer pieces packed 250
	ACP 5036 Metal wall spacer pieces packed 100
	ACP 5093 Box covers pairs packed 1

	ACP 5095 Roller shutter guide supports pairs packed 50
	ACP 50010 Winder without plate pieces packed 1
	ACP 50011 Plate for winder pieces packed 1
	ACP 50095 Box belt guide pieces packed 1
	ACP 50117D Right bracket for square support ACP50220 pairs packed 1
	ACP 50117S Left bracket for square support ACP50220 pairs packed 1
	ACP 50120D Right bracket for vertical support ACP50320 pairs packed 1
	ACP 50120S Left bracket for vertical support ACP50320 pairs packed 1

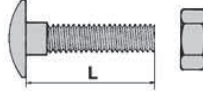
	<p>ACP 50220</p> <p>Triangle bracket 46x10 for shutter roller</p> <p>pairs packed 1</p>
	<p>ACP 50320</p> <p>Vertical support 40x5 for shutter roller</p> <p>pairs packed 1</p>
	<p>ACP 50536</p> <p>Sloping spacer</p> <p>pieces packed 100</p>
	<p>ACP 50537</p> <p>Profile drilling position template for fitting ACP 50536</p> <p>pieces packed 1</p>
	<p>ACP 50538</p> <p>Two diameter cutter for fitting the sloping spacer</p> <p>pieces packed 1</p>
	<p>ACP 5523</p> <p>Plug for beadless glazing profiles</p> <p>pieces packed 50</p>
	<p>ACP 5562</p> <p>Plug for central profile Planet Matic 50TT and 62TT for profile TT 51213 and TT 61213</p> <p>pieces packed 20</p>

	<p>ACP 50704</p> <p>Semi-embedded box</p> <p>pieces packed 1</p>
	<p>ACP 50705</p> <p>Winder with black plate for roller shutter belt</p> <p>pieces packed 1</p>
	<p>ACP 50825</p> <p>180mm pulley</p> <p>pieces packed 1</p>
	<p>ACP 50832</p> <p>Roller support cover</p> <p>pieces packed 1</p>
	<p>ACP 51520</p> <p>Support/bracket fastening screw</p>
	<p>ACP 51001</p> <p>Jamb belt guide</p> <p>pieces packed 200</p>
	<p>ACP 51190</p> <p>Joint bushing, for roller/pulley and roller/cover</p> <p>pieces packed 1</p>
	<p>ACP 6230</p> <p>Planet 62TT glass support</p> <p>pieces packed 100</p>

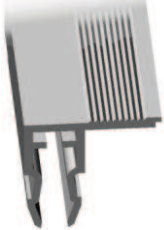
	<p>ACP 6245</p> <p>galvanised profile for thermal counter-frame (profile length 3m)</p> <p>bars packed 20</p>
	<p>ACP 6245.1</p> <p>PVC profile for thermal counter-frame (profile length 3m)</p> <p>bars packed 20</p>

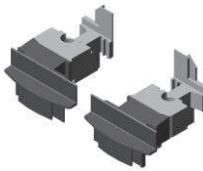
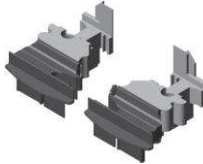
	<p>ACP 62178</p> <p>Plug for Planet 62 TT central connection profile, double rebate version</p> <p>pairs packed 20</p>
	<p>ACP 62179</p> <p>Plug for Planet 62 TT central connection profile, open joint version</p> <p>pairs packed 20</p>

List of joint accessories

	<p>AC 2001</p> <p>Trilobate screw for acp 5020</p> <p>pieces packed 250</p>		<p>ACP 5084</p> <p>Alignment corner bracket with tightening screw for frames and wall profiles</p> <p>pieces packed 250</p>
	<p>AC 5000</p> <p>ø 8mm pin for clamp acp 5020</p> <p>pieces packed 400</p>		<p>ACP 50110</p> <p>Alignment corner bracket with tightening eccentrics</p> <p>pieces packed 250</p>
	<p>ACP 5001</p> <p>Screw for multi-purpose corner bracket ACP 5801, ACP 5802, ACP 7001</p> <p>pieces packed 1000</p>		<p>ACP 50153</p> <p>Multi-purpose bracket 4x14mm broaching-crimping and screwing</p> <p>pieces packed 200</p>
	<p>ACP 5002</p> <p>Corner bracket 23x14 mm with push-button ø 10mm strong - threaded</p> <p>pieces packed 250</p>		<p>ACP 50154</p> <p>Multi-purpose bracket 4x36mm broaching-crimping and screwing</p> <p>pieces packed 200</p>
	<p>ACP 5008</p> <p>Alignment corner bracket in stainless steel</p> <p>pieces packed 400</p>		<p>ACP 50420</p> <p>Snap clamp 23x14 mm extruded</p> <p>pieces packed 100</p>
	<p>ACP 50155</p> <p>Stainless steel screw for multi-purpose corner brackets ACP 50153 and ACP 50154</p> <p>pieces packed 400</p>		<p>ACP 50454</p> <p>Snap clamp, extruded for TT7138</p> <p>pieces packed 100</p>
	<p>ACP 5030</p> <p>Pin diam. 3 mm with stem for multi-purpose brackets ACP 50153 and ACP 50154</p> <p>pieces packed 400</p>		<p>ACP 5501</p> <p>Oversized bracket 23x35 mm with push-button</p> <p>pieces packed 250</p>

	<p>ACP 5502</p> <p>Bracket 17.5x15 mm with push-button for reversal TT61123</p> <p>pieces packed 250</p>
	<p>ACP 5504</p> <p>Bracket 23x14 mm, variable angle, min 30° max 178°</p> <p>pieces packed 20</p>
	<p>ACP 5521</p> <p>Clamp 23x14 mm, die-cast, with push-button</p> <p>pairs packed 250</p>
	<p>ACP 7001</p> <p>Multi-purpose bracket 17.5x15 mm, screwing, broaching and crimping for reversal TT 61123</p> <p>pieces packed 250</p>
	<p>ACP 5800</p> <p>Pin for multi-purpose bracket ACP 5801, ACP 5802, ACP 7001</p> <p>pieces packed 1000</p>
	<p>ACP 5801</p> <p>Multi-purpose bracket 23x14 mm, screwing, broaching and crimping</p> <p>pieces packed 200</p>

	<p>ACP 5802</p> <p>Multi-purpose oversized bracket 23x35 mm, screwing, broaching and crimping</p> <p>pieces packed 100</p>
	<p>ACP 5805</p> <p>Bracket 23x14 mm variable angle - strong min 60° max 120°</p> <p>pieces packed 20</p>
	<p>ACP 5821</p> <p>Clamp 23x14 mm die-cast with dowel and shank</p> <p>pieces packed 250</p>
	<p>ACP 7207</p> <p>Alignment clamp for the external body of straight profiles</p> <p>pieces packed 250 right – 250 left</p>
	<p>ACP 7208</p> <p>Alignment clamp for the external body of rounded profiles</p> <p>pieces packed 250 right – 250 left</p>

List of closing accessories







	<p>AC 2068</p> <p>Small handle with plate</p> <p>pieces packed 25</p>		<p>ACP 5007</p> <p>3rd leaf hinge, pre-assembled stainless steel components and plates, use 1 pair $h_{max}=1800mm$ for h over 1800mm insert the 3rd hinge</p> <p>pieces packed 50</p>
	<p>AC 2069</p> <p>Shutter hinge</p> <p>pieces packed 50</p>		<p>ACP 5007D</p> <p>3rd leaf right hinge, pre-assembled, use 1 pair $h_{max}=1800mm$ for h over 1800mm insert the 3rd hinge</p> <p>pieces packed 50</p>
	<p>ACP 1606</p> <p>Nylon base plate for window handle for assembly on convex leaves</p> <p>pieces packed 50</p>		<p>ACP 5007S</p> <p>3rd leaf left hinge, pre-assembled, use 1 pair $h_{max}=1800mm$ for h over 1800mm insert the 3rd hinge</p> <p>pieces packed 50</p>
	<p>ACP 5005</p> <p>Hinge for flat frames, pre-assembled stainless steel components and plates, use 1 pair $h_{max}=1800mm$ for h over 1800mm insert the 3rd hinge</p> <p>pieces packed 50</p>		<p>ACP 5009</p> <p>8mm shim for front-fitted hinges</p> <p>pieces packed 8</p>
	<p>ACP 5005D</p> <p>Pre-assembled right hinge, for flat frames, use 1 pair $h_{max}=1800mm$ for h over 1800mm insert the 3rd hinge</p> <p>pieces packed 50</p>		<p>ACP 5010</p> <p>Vasistas double snap hinge</p> <p>pairs packed 20</p>
	<p>ACP 5005S</p> <p>Pre-assembled left hinge, for flat frames, use 1 pair $h_{max}=1800mm$ for h over 1800mm insert the 3rd hinge</p> <p>pieces packed 50</p>		<p>ACP 5011</p> <p>Top-hinged telescopic arms for projected windows</p> <p>pairs packed 20</p>
	<p>ACP 5006</p> <p>3-wing hinge for flat frames, stainless steel components and pre-assembled plates,</p> <p>pieces packed 25</p>		<p>ACP 5012</p> <p>Vasistas single snap hinge</p> <p>pairs packed 25</p>

	<p>ACP 5013</p> <p>Vasistas finger catch</p> <p>pieces packed 100</p>
	<p>ACP 5015</p> <p>7mm shim for front-fitted hinges</p> <p>pieces packed 8</p>
	<p>ACP 5016</p> <p>Stainless steel releasable arm</p> <p>pairs packed 40</p>
	<p>ACP 5017</p> <p>Vasistas quick fitting finger catch</p> <p>pieces packed 50</p>
	<p>ACP 5018</p> <p>Large hinge for flat frames, pre-assembled stainless steel components and plates, strong with 2 wings.</p> <p>pieces packed 12</p>
	<p>ACP 5019</p> <p>3rd latch striker plate</p> <p>pieces packed 200</p>
	<p>ACP 5021</p> <p>3rd adjustable latch kit</p> <p>kit packed 100</p>
	<p>ACP 5022</p> <p>Bolt</p> <p>pieces packed 100</p>

	<p>ACP 5024</p> <p>Double rod striker in zamak</p> <p>pieces packed 400</p>
	<p>ACP 5025</p> <p>Rod terminal</p> <p>pieces packed 200</p>
	<p>ACP 5026</p> <p>Leaf support plate</p> <p>pieces packed 400</p>
	<p>ACP 5028</p> <p>Large hinge for flat frames, pre-assembled stainless steel components and plates, strong with 3 wings.</p> <p>pieces packed 12</p>
	<p>ACP 5029</p> <p>Stainless steel security bolt for hinges ACP 5018, ACP 5028, ACP 5038</p> <p>pieces packed 400</p>
	<p>ACP 5032</p> <p>Handle for cremone bolt</p> <p>pieces packed 40</p>
	<p>ACP 5033</p> <p>Cremone bolt without handle</p> <p>pieces packed 20</p>
	<p>ACP 5034</p> <p>Cremone bolt with key</p> <p>pieces packed 20</p>

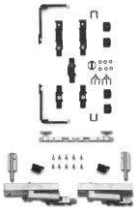



	<p>ACP 5037</p> <p>One-way cremone bolt for tilt and parallel sliding leaves</p> <p>pieces packed 1</p>
	<p>ACP 5038</p> <p>Large hinge for flush frames, pre-assembled stainless steel components and plates - strong with 2 wings for 3rd leaf</p> <p>pieces packed 12</p>
	<p>ACP 5039</p> <p>Double handle for doors</p> <p>pairs packed 20</p>
	<p>ACP 5041</p> <p>Spacer 35-47 mm for front-fitted hinges</p> <p>pieces packed 10</p>
	<p>ACP 5042</p> <p>60 mm screw for hinges to be fitted frontally on frame profiles in the open-out solution with side fixed elements</p> <p>pieces packed 250</p>
	<p>ACP 5043</p> <p>Hinge kit for leaves combined with flat frames (flush externally / overlapping internally)</p> <p>pairs packed 10</p>
	<p>ACP 5044</p> <p>Hinge kit for leaves combined with moulded frames (Flush externally, flush internally)</p> <p>pairs packed 10</p>
	<p>ACP 5045</p> <p>Cremone bolt connection blocks in zamak</p> <p>pairs packed 160</p>

	<p>ACP 5046/350</p> <p>Tilt window arm 345/410mm</p> <p>Pieces packed 10</p>
	<p>ACP 5046/411</p> <p>Tilt window arm 411/540mm</p> <p>pieces packed 10</p>
	<p>ACP 5046/541</p> <p>Tilt window arm 541/1500mm</p> <p>pieces packed 10</p>
	<p>ACP 5047</p> <p>Combined leaf latch kit</p> <p>kit packed 10</p>
	<p>ACP 5049</p> <p>Supplementary arm</p> <p>pieces packed 10</p>
	<p>ACP 5052</p> <p>Aluminium latch kit with adjustment eccentric for semi-fixed leaf</p> <p>kit packed 20</p>
	<p>ACP 5053</p> <p>Rod joint for latch ACP 5052 extension</p> <p>pieces packed 100</p>
	<p>ACP 5056</p> <p>Supplementary horizontal latch kit</p> <p>kit packed 1</p>

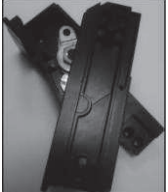
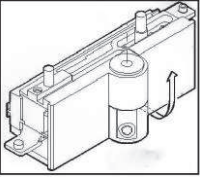

	<p>ACP 5057</p> <p>Supplementary vertical latch kit</p> <p>kit packed 5</p>
	<p>ACP 5059D</p> <p>Right parallel sliding base kit Capacity 150kg per leaf</p> <p>kit packed 1</p>
	<p>ACP 5059S</p> <p>Left parallel sliding base kit Capacity 150kg per leaf</p> <p>kit packed 1</p>
	<p>ACP 5060/1930</p> <p>Track kit for parallel sliding Frame length= from 930 to 1930mm</p> <p>Kit packed 1</p>
	<p>ACP 5060/2630</p> <p>Track kit for parallel sliding Frame length= from 1280 to 2630mm</p> <p>Kit packed 1</p>
	<p>ACP 5060/3430</p> <p>Track kit for parallel sliding Frame length= from 1680 to 3430mm</p> <p>Kit packed 1</p>
	<p>ACP 5061/930</p> <p>Scissor hinge kit, parallel sliding Leaf length= from 630 to 930mm</p> <p>Kit packed 1</p>

	<p>ACP 5061/1280</p> <p>Scissor hinge kit, parallel sliding Leaf length= from 931 to 1280mm</p> <p>Kit packed 1</p>
	<p>ACP 5061/1680</p> <p>Scissor hinge kit, parallel sliding Leaf length= from 1281 to 1680mm</p> <p>Kit packed 1</p>
	<p>ACP 5063/60</p> <p>3-wing door hinge front fitting centre distance 60mm</p> <p>Pieces packed 10</p>
	<p>ACP 5063/93</p> <p>3-wing door hinge front fitting centre distance 93mm</p> <p>Pieces packed 10</p>
	<p>ACP 5064/60</p> <p>2-wing door hinge front fitting centre distance 60mm</p> <p>pieces packed 10</p>
	<p>ACP 5064/93</p> <p>2-wing door hinge front fitting centre distance 93mm</p> <p>pieces packed 10</p>
	<p>ACP 5065</p> <p>Bushing to bring the pin diameter from $\varnothing 6$ to $\varnothing 8$</p> <p>pieces packed</p>
	<p>ACP 5067</p> <p>Window handle control E=33.5mm</p> <p>pieces packed 1</p>

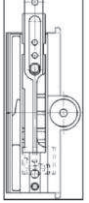
	<p>ACP 5069</p> <p>3rd leaf 3-wing hinge, pre-assembled stainless steel components and plates,</p> <p>pieces packed 25</p>
	<p>ACP 5076</p> <p>Lever handle</p> <p>pieces packed 20</p>
	<p>ACP 5081</p> <p>Single rod striker in nylon</p> <p>pieces packed 100</p>
	<p>ACP 5082</p> <p>Double rod striker in nylon</p> <p>pieces packed 100</p>
	<p>ACP 5086</p> <p>4 point lock kit, vertical pivot</p> <p>kit packed 1</p>
	<p>ACP 5088</p> <p>4-point lock kit, horizontal pivot</p> <p>Kit packed 1</p>
	<p>ACP 5090</p> <p>Friction joint for pivot window without stop Capacity 75 kg</p> <p>pairs packed 3</p>
	<p>ACP 5091</p> <p>Friction joint for pivot window with stop Capacity 75 kg</p> <p>pairs packed 3</p>

	<p>ACP 5092</p> <p>Friction joint for horizontal pivot window, capacity 175 kg</p> <p>Kit packed 1</p>
	<p>ACP 5092V</p> <p>Friction joint for vertical pivot window, capacity 175 kg Combine with transmission rod ACP 50102</p> <p>Kit packed 1</p>
	<p>ACP 5094</p> <p>Stainless steel shim for adjustment between ACP 5092 / ACP 5092V friction joint and pivot leaf profile</p> <p>pieces packed 1</p>
	<p>ACP 5098</p> <p>Universal template for front-fitting hinges, int. 60 and int.93</p> <p>pieces packed 1</p>
	<p>ACP 50100</p> <p>Two-way cremone bolt Planet giada</p> <p>pieces packed 20</p>
	<p>ACP 50101</p> <p>Anti-roll plate for cremone bolt, including screws</p> <p>pieces packed 10</p>
	<p>ACP 50102</p> <p>Transmission rod for friction joint ACP 5092V for right vertical pivot</p> <p>pieces packed</p>

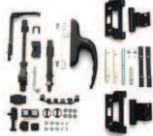
	<p>ACP 50103</p> <p>Opening restrictor for pivot friction joint ACP 5092 and ACP 5092V</p> <p>Pieces packed</p>
	<p>ACP 50112</p> <p>2-wing front-fitting hinges fixing kit</p> <p>pieces packed 10</p>
	<p>ACP 50113</p> <p>3-wing front-fitting hinges fixing kit</p> <p>pieces packed 10</p>

	<p>ACP 50150</p> <p>Tilt leaf kit for flat frames, including hinges and cremone bolt (flush externally / overlapping internally)</p> <p>kit packed 1</p>
	<p>ACP 50151</p> <p>Tilt leaf kit for flush frames, including hinges and cremone bolt (Flush externally, flush internally)</p> <p>kit packed 1</p>
	<p>ACP 8007</p> <p>Window handle</p> <p>pieces packed 5</p>

1 leaf window

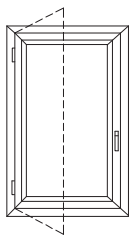

Glass list

No. of pieces	L	H
1	L-148	H-148

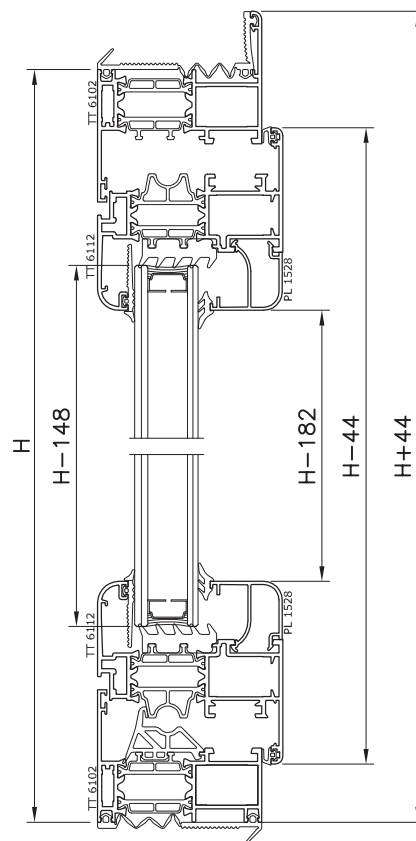
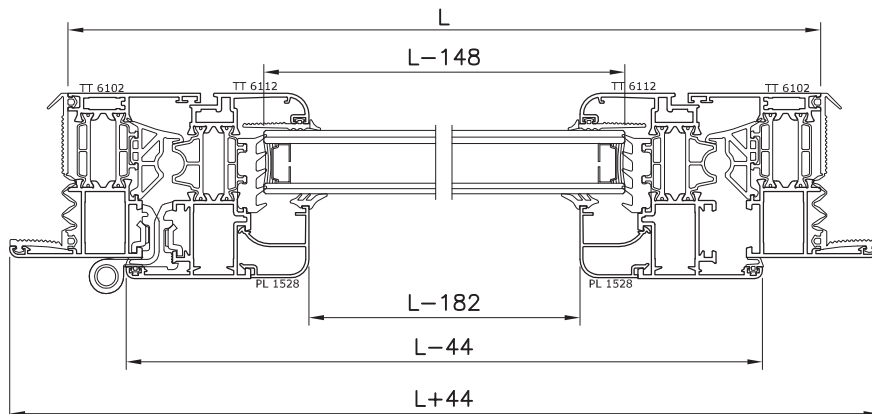

List of profiles

Item	description	pieces	size	cut
TT 6102	upper frame crosspiece	1	L+44	
TT 6103	lower frame crosspiece	1	L	
TT 6102	frame jamb	2	H+44	
TT 6112	leaf crosspiece	2	L-44	
	leaf jamb	2	H-44	
PL 1528	glazing bead crosspiece	2	L-182	
	glazing bead jamb	2	H-182	

List of accessories

item	description	qty
ACP 5801	multi-purpose bracket	8 pz
ACP 5008	stainless steel align. bracket	6 pz
ACP 50110	eccentric alignment bracket	4 pz
ACP 50153	ext. crimping bracket	8 pz
ACP 5005	hinge	2 pz
ACP 50100	cremone bolt giada	1 pz
ACP 5045	connection blocks	1 cp
ACP 5025	rod terminal	2 pz
ACP 5024	zamak striker	2 pz
ACP 5035	nylon wall guide	6/8 pz
ACP 5014	glazing bead angles	4 pz
AGP 6285	vulcanised corner	4 pz
ACP 5001	screw for bracket	16 pz

List of gaskets

Item	description	pieces	size
AGP 4000	rebate	2	L-44
		2	H-44
AGP 4031	under glass	2	L-128
		2	H-128
AGP 4099	wall insulation	2	L+44
		2	H+22
AGP 6272	open joint fin	2	L-124
		2	H-124
depends on the glass	external glass	2	L-148
		2	H-148
depends on the glass	internal glass	2	L-148
		2	H-148

N.B. all the tables shown in our catalogues have been obtained using purely theoretical calculations and do not take extrusion tolerance, painting and machining into account; we therefore advise you to test them properly before producing

Window 2 leaves

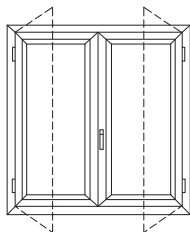

List of glass

No. of pieces	L	H
2	L/2-128.5	H-148

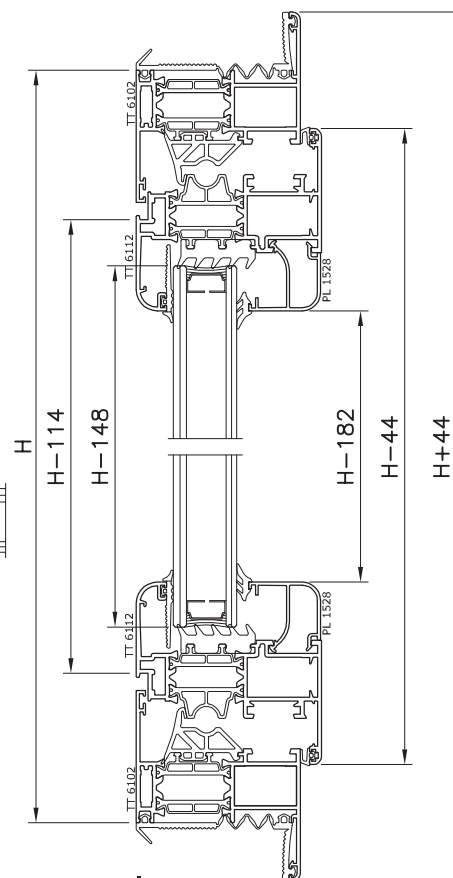
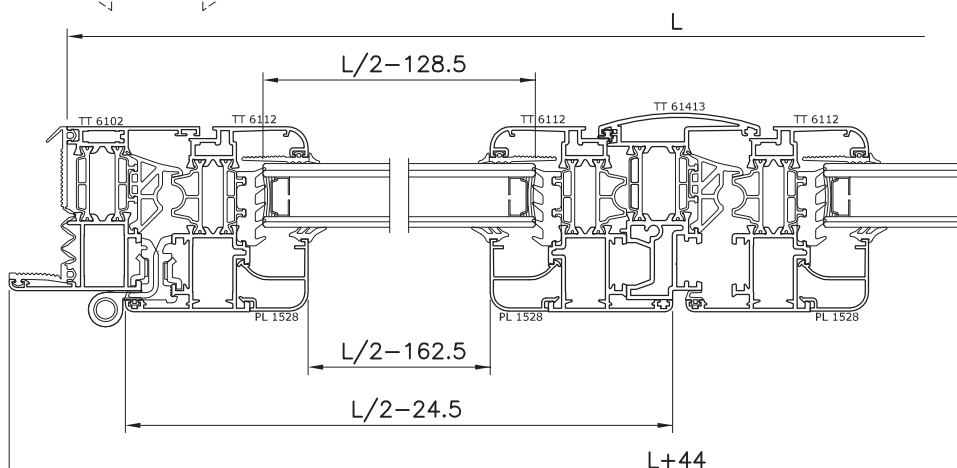

List of profiles

Item	description	pieces	size	cut
TT 6102	frame crosspiece	2	L+44	
	frame jamb	2	H+44	
TT 6112	leaf crosspiece	4	L/2-24.5	
	leaf jamb	4	H-44	
PL 1528	glazing bead crosspiece	4	L/2-162.5	
	glazing bead jamb	4	H-182	
TT 61413	central connection profile	1	H-114	

List of gaskets

Item	description	pieces	size
AGP 4000		rebate	4 L/2-24.5
			3 H-44
AGP 4031		under glass	4 L/2-108.5
			4 H-128
AGP 4099		wall insulation	2 L+44
			2 H+44
AGP 6272		open joint fin	2 L-124
			3 H-124
depends on the glass		external glass	4 L/2-128.5
			4 H-148
depends on the glass		internal glass	4 L/2-128.5
			4 H-148
AGP 4006		open joint rebate	1 H-114

List of accessories

Item	description	qty
ACP 5801	multi-purpose bracket	12 pz
ACP 5008	stainless steel align. bracket	12 pz
ACP 50110	eccentric alignment bracket	8 pz
ACP 50153	ext. crimping bracket	12 pz
ACP 5005	hinge	4 pz
ACP 50100	cremone bolt giada	1 pz
ACP 5045	connecting block	1 cp
ACP 5025	rod terminal	2 pz
ACP 5024	zamac striker	2 pz
ACP 5022	latch	2 pz
ACP 5035	nylon wall guide	6/8 pz
ACP 5014	glazing bead angles	8 pz
ACP 62179	connection profile cap	1 cp
AGP 6285	vulcanised corner	4 pz
ACP 5001	screw for bracket	24 pz

N.B. all the tables shown in our catalogues have been obtained using purely theoretical calculations and do not take extrusion tolerance, painting and machining into account; we therefore advise you to test them properly before producing

2-leaf tilt and turn window

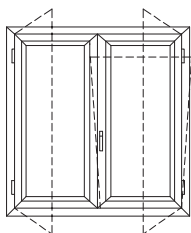

List of glass

No. of pieces	L	H
2	L/2-128.5	H-148

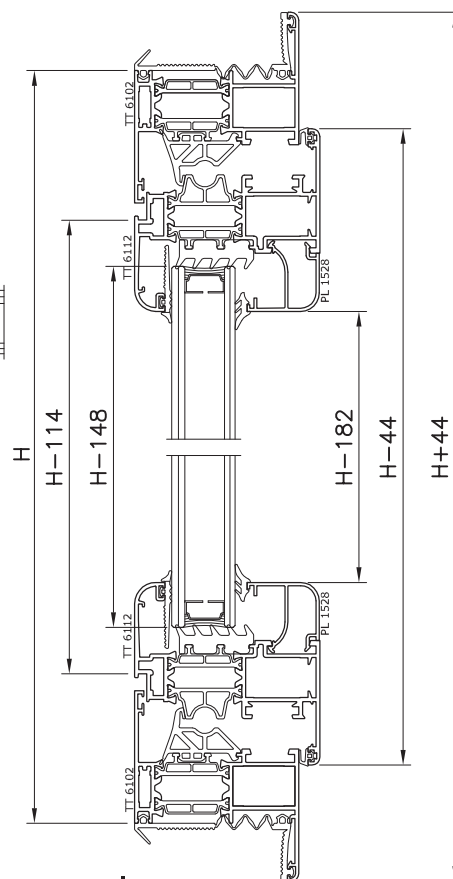
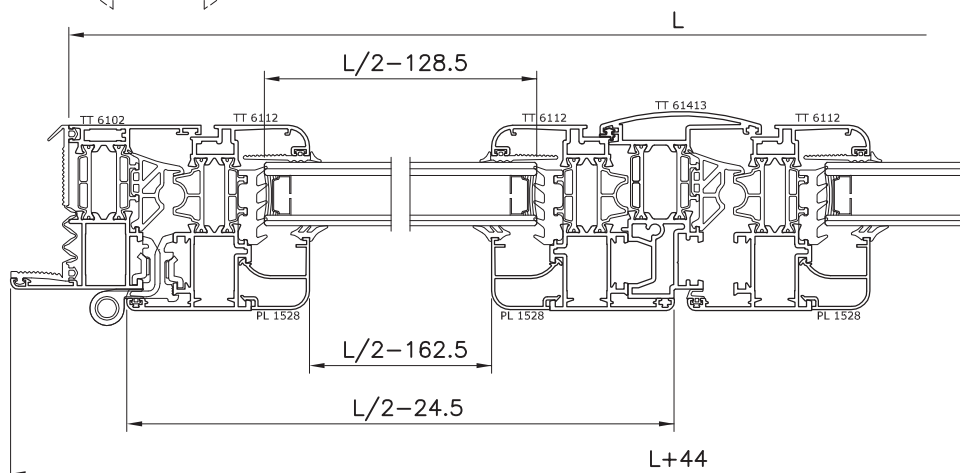

List of profiles

Item	description	pieces	size	cut
TT 6102	frame crosspiece	2	L+44	
	frame jamb	2	H+44	
TT 6112	leaf crosspiece	4	L/2-24.5	
	leaf jamb	4	H-44	
PL 1528	glazing bead crosspiece	4	L/2-162.5	
	glazing bead jamb	4	H-182	
TT 61413	central connection profile	1	H-114	

List of gaskets

Item	description	pieces	size
AGP 4000		4	L/2-24.5
		3	H-44
AGP 4031		4	L/2-108.5
		4	H-128
AGP 4099		2	L+44
		2	H+44
AGP 6272		2	L-124
		3	H-124
depends on the glass		4	L/2-128.5
		4	H-148
depends on the glass		4	L/2-128.5
		4	H-148
AGP 4006		1	H-114

List of accessories

Item	description	qty
ACP 5801	multi-purpose bracket	12 pz
ACP 5008	stainless steel align. bracket	12 pz
ACP 50110	eccentric align. bracket	8 pz
ACP 50153	ext. crimping bracket	12 pz
ACP 5043	leaf hinge comb. kit	1 kit
ACP 5037	tilt leaf cremone bolt	1 pz
ACP 5050	tilt leaf kit	1 kit
ACP 5052	latch kit	1 kit
ACP 5035	nylon wall guide	6/8 pz
ACP 5014	glazing bead angles	8 pz
ACP 62179	connection profile cap	1 cp
AGP 6285	vulcanised corner	4 pz
ACP 5046	tilt and turn leaf arm	1 pz
ACP 5001	screw for bracket	24 pz

N.B. all the tables shown in our catalogues have been obtained using purely theoretical calculations and do not take extrusion tolerance, painting and machining into account; we therefore advise you to test them properly before producing

3-leaf window

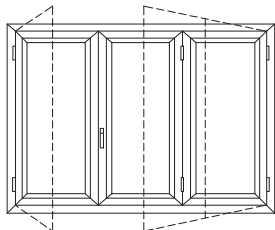

List of glass

No. of pieces	L	H
3	L/3-122	H-148

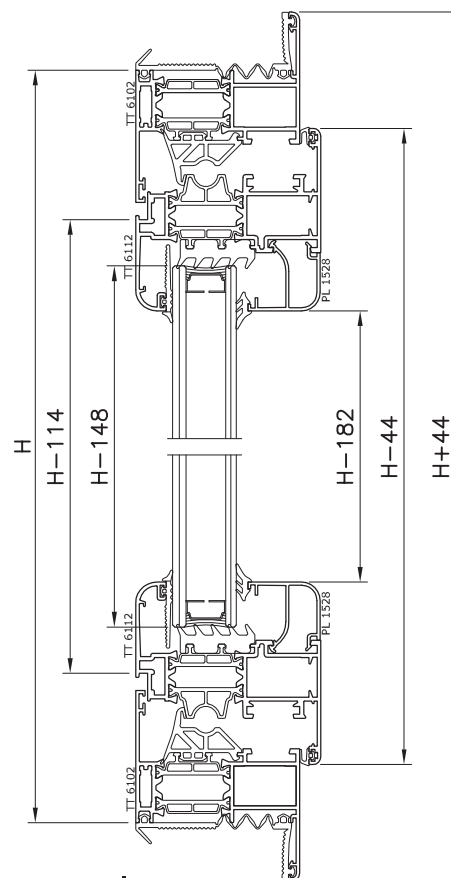
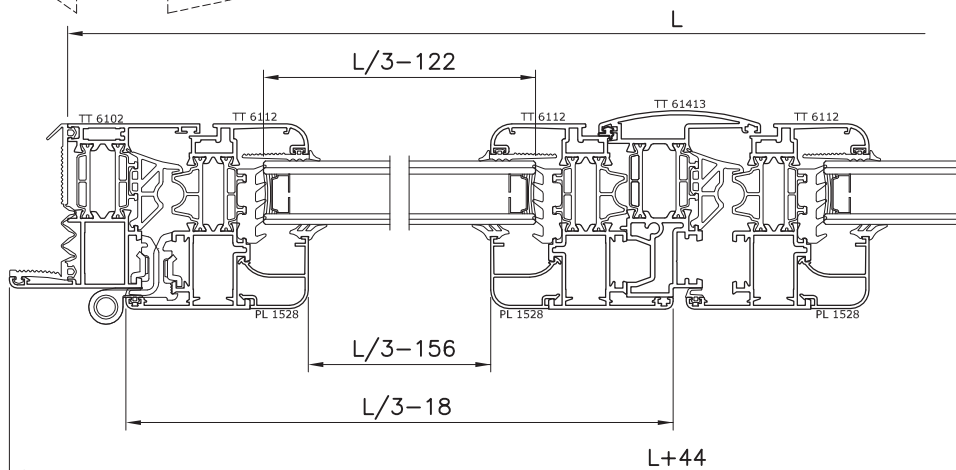

List of profiles

Item	description	pieces	size	cut
TT 6102	frame crosspiece	2	L+44	
	frame jamb	2	H+44	
TT 6112	leaf crosspiece	6	L/3-18	
	leaf jamb	6	H-44	
PL 1528	glazing bead crosspiece	6	L/3-156	
	glazing bead jamb	6	H-182	
TT 61413	central connection profile	2	H-114	

List of accessories

Item	description	qty
ACP 5801	multi-purpose bracket	16 pz
ACP 5008	stainless steel align. bracket	16 pz
ACP 50110	eccentric align. bracket	12 pz
ACP 50153	ext. crimping bracket	16 pz
ACP 5005	hinge	4 pz
ACP 5007	hinge 3rd leaf	2 pz
ACP 50100	cremone bolt jade	1 pz
ACP 5045	connection blocks	1 cp
ACP 5025	rod terminal	2 pz
ACP 5024	zamac striker	4 pz
ACP 5022	latch	4 pz
ACP 5026	leaf support plate	1 pz
ACP 5035	nylon wall guide	6/8 pz
ACP 5014	glazing bead angles	12 pz
ACP 62179	connection profile cap	2 cp
AGP 4885	vulcanised corner	4 pz
ACP 5001	screw for bracket	32 pz

List of gaskets

Item	description	pieces	size
AGP 4000	rebate	6	L/3-18
		4	H-44
AGP 4031	under glass	6	L/3-102
		6	H-128
AGP 4099	wall insulation	2	L+44
		2	H+44
AGP 6272	open joint fin	2	L-124
		4	H-124
depends on the glass	external glass	6	L/3-122
		6	H-148
depends on the glass	internal glass	6	L/3-122
		6	H-148
AGP 4006	open joint rebate	2	H-114

N.B. all the tables shown in our catalogues have been obtained using purely theoretical calculations and do not take extrusion tolerance, painting and machining into account; we therefore advise you to test them properly before producing

4-leaf window

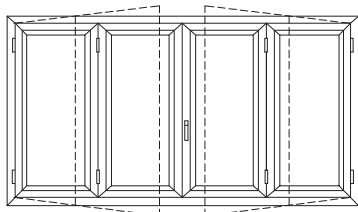

List of glass

No. of pieces	L	H
4	L/4-119	H-148

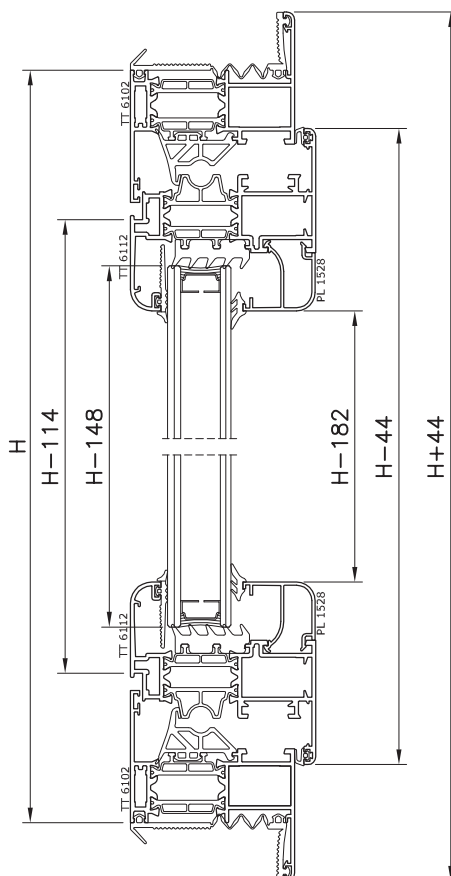
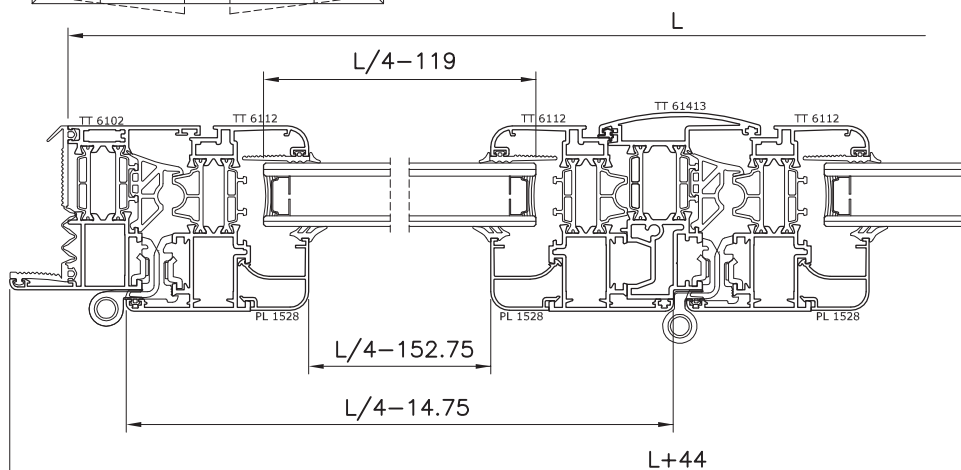

List of profiles

Item	description	pieces	size	cut
TT 6102	frame crosspiece	2	L+44	
	frame jamb	2	H+44	
TT 6112	leaf crosspiece	8	L/4-14.75	
	leaf jamb	8	H-44	
PL 1528	glazing bead crosspiece	8	L/4-152.75	
	glazing bead jamb	8	H-182	
TT 61413	central connection profile	3	H-114	

List of gaskets

Item	description	pieces	size
AGP 4000	rebate	8	L/4-14
		5	H-44
AGP 4031	under glass	8	L/4-99
		8	H-128
AGP 4099	wall insulation	2	L+44
		2	H+44
AGP 6272	open joint fin	2	L-124
		5	H-124
depends on the glass	external glass	8	L/4-119
		8	H-148
depends on the glass	internal glass	8	L/4-119
		8	H-148
AGP 4006	open joint rebate	3	H-114

List of accessories

Item	description	qty
ACP 5801	multi-purpose bracket	20 pz
ACP 5008	stainless steel align. bracket	20 pz
ACP 50110	eccentric align. bracket	16 pz
ACP 50153	ext. crimping bracket	20 pz
ACP 5005	hinge	4 pz
ACP 5007	hinge 3rd leaf	4 pz
ACP 50100	cremone bolt jade	1 pz
ACP 5045	connection blocks	1 cp
ACP 5025	rod terminal	2 pz
ACP 5024	zamak striker	6 pz
ACP 5022	latch	6 pz
ACP 5026	leaf support plate	2 pz
ACP 5035	nylon wall guide	6/8 pz
ACP 5014	glazing bead angles	16 pz
ACP 62179	connection profile cap	3 cp
AGP 6285	vulcanised corner	4 pz
ACP 5001	screw for bracket	40 pz

N.B. All the tables shown in our catalogues have been obtained using purely theoretical calculations and do not take extrusion tolerance, painting and machining into account; we therefore advise you to test them properly before producing

1-leaf glass door

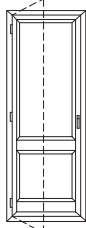

List of glass

No. of pieces	L	H
1	L-148	H1-197
1	L-148	H2-103

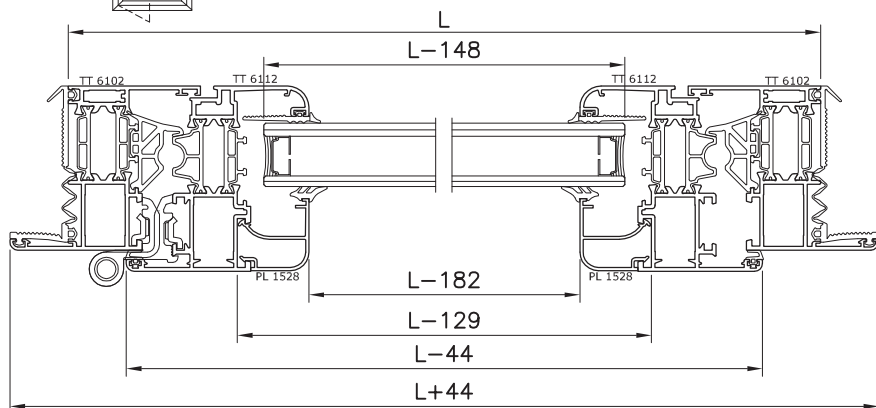

List of profiles

Item	description	pieces	size	cut
TT 6102	upper frame crosspiece	1	L+44	
TT 6103	lower frame crosspiece	1	L	
TT 6102	frame jamb	2	H+44	
TT 6112	leaf crosspiece	2	L-44	
	leaf jamb	2	H-44	
PL 1528	glazing bead crosspiece	4	L-182	
	glazing bead jamb	2	H1-231	
	glazing bead jamb	2	H2-137	
TT 6147	fitted base	1	L-129	
TT 61138	central crossbeam	1	L-129	

List of gaskets

Item	description	pieces	size
AGP 4000	rebate	2	L-44
		2	H-44
AGP 4031	under glass	4	L-128
		2	H2-83
		2	H1-177
AGP 4099	wall insulation	2	L+44
		2	H+44
AGP 6272	open joint fin	2	L-124
		2	H-124
depends on the glass	external glass	4	L-148
		2	H1-197
		2	H2-103
depends on the glass	internal glass	4	L-148
		2	H1-197
		2	H2-103

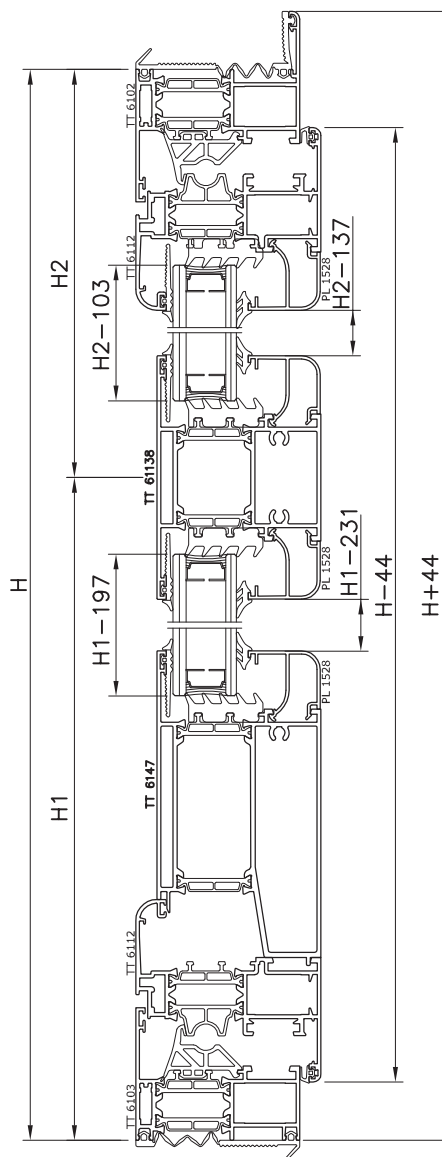

List of accessories

Item	description	qty
ACP 5801	multi-purpose bracket	8 pz
ACP 5008	stainless steel align. bracket	6 pz
ACP 50110	eccentric align. bracket	4 pz
ACP 50153	ext. crimping bracket	8 pz
ACP 5005	hinge	3 pz
ACP 50100	cremone bolt jade	1 pz
ACP 5045	connection blocks	1 cp
ACP 5025	rod terminal	2 pz
ACP 5024	zamak striker	2 pz
ACP 5035	nylon wall guide	6/8 pz
ACP 5014	glazing bead angles	8 pz
AGP 6285	vulcanised corner	4 pz
ACP 7208	alignment clamp	4 pz
ACP 5001	screw for bracket	16 pz

N.B. all the tables shown in our catalogues have been obtained using purely theoretical calculations and do not take extrusion tolerance, painting and machining into account; we therefore advise you to test them properly before producing

2-leaf glass door

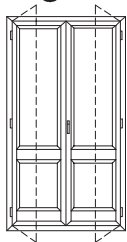

List of glass

No. of pieces	L	H
2	L/2-128.5	H1-197
2	L/2-128.5	H2-103

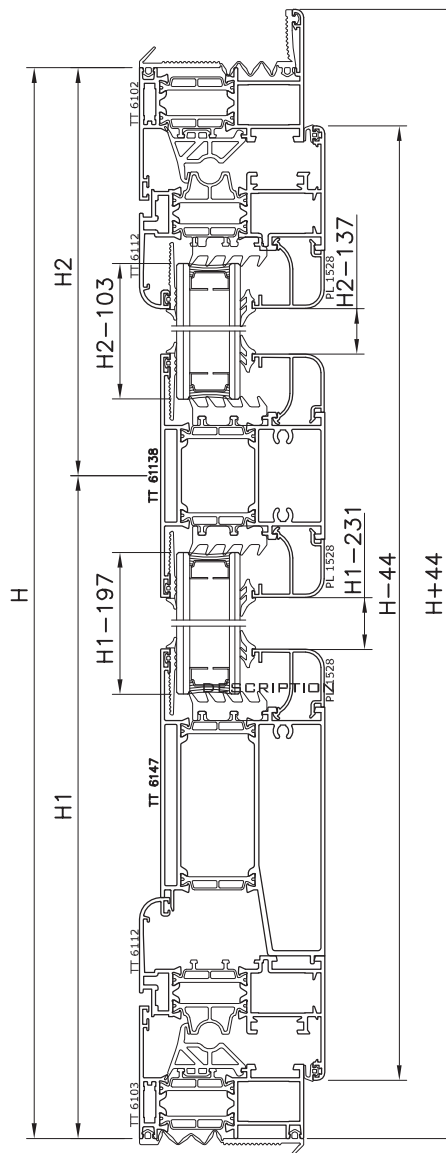
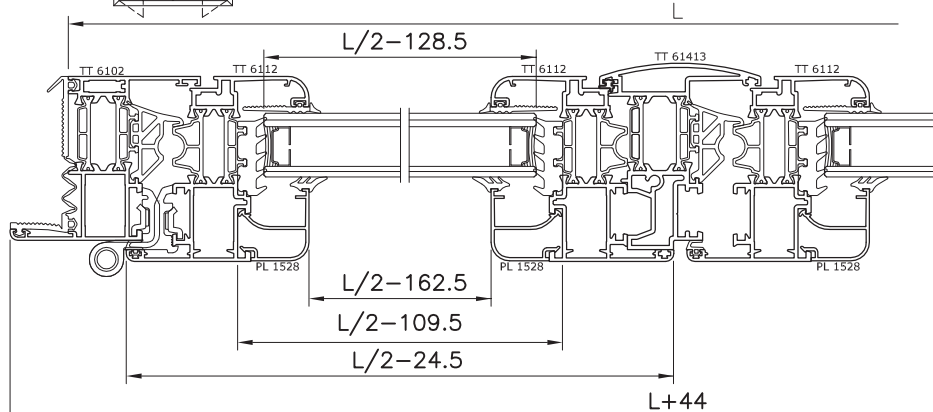

List of profiles

Item	description	pieces	size	cut
TT 6102	upper frame crosspiece	1	L+44	
TT 6103	lower frame crosspiece	1	L	
TT 6102	frame jamb	2	H+44	
TT 6112	leaf crosspiece	4	L/2-24.5	
	leaf jamb	4	H-44	
PL 1528	glazing bead crosspiece	8	L/2-162.5	
	glazing bead jamb	4	H1-231	
	glazing bead jamb	4	H2-137	
TT 6147	fitted base	2	L/2-109.5	
TT 61138	central crossbeam	2	L/2-109.5	
TT 61413	central connection frame	1	H-114	

List of gaskets

Item	description	pieces	size
AGP 4000		4	L/2-24.5
		3	H-44
AGP 4031		8	L/2-108.5
		4	H2-83
		4	H1-177
AGP 4099		2	L+44
		2	H+22
AGP 6272		2	L-124
		3	H-124
depends on the glass		8	L/2-128.5
		4	H1-197
		4	H2-103
depends on the glass		8	L/2-128.5
		4	H1-197
		4	H2-103
AGP 4006		1	H-114

List of accessories

Item	description	qty
ACP 5801	multi-purpose bracket	12 pz
ACP 5008	stainless steel align. bracket	12 pz
ACP 50110	eccentric align. bracket	8 pz
ACP 50153	ext. crimping bracket	12 pz
ACP 5005	hinge	6 pz
ACP 50100	cremone bolt jade	1 pz
ACP 5045	connection blocks	1 cp
ACP 5025	rod terminal	2 pz
ACP 5024	zamak striker	2 pz
ACP 5022	latch	2 pz
ACP 5035	nylon wall guide	6/8 pz
ACP 5014	glazing bead angles	16 pz
ACP 62179	connection profile cap	1 cp
AGP 6285	vulcanised corner	4 pz
ACP 7208	alignment clamp	8 pz
ACP 5001	screw for bracket	24 pz

N.B. all the tables shown in our catalogues have been obtained using purely theoretical calculations and do not take extrusion tolerance, painting and machining into account; we therefore advise you to test them properly before producing

Open-in 1-leaf entrance door

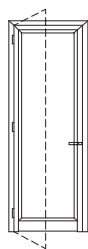

List of glass

No. of pieces	L	H
1	L-256	H-281

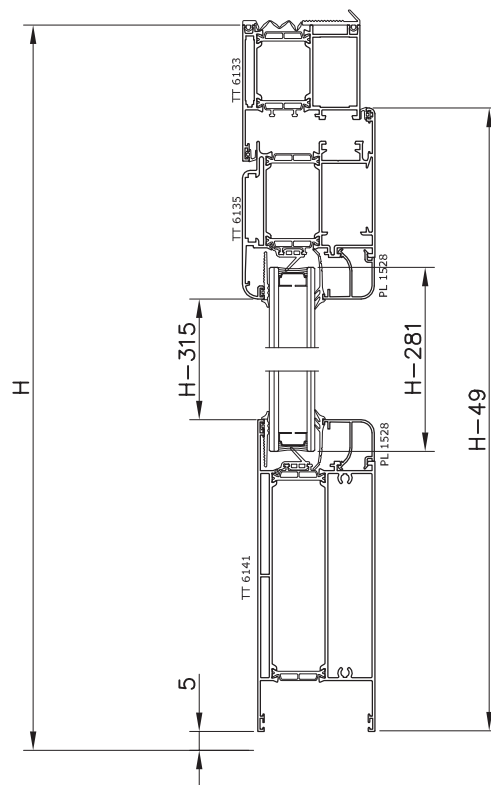
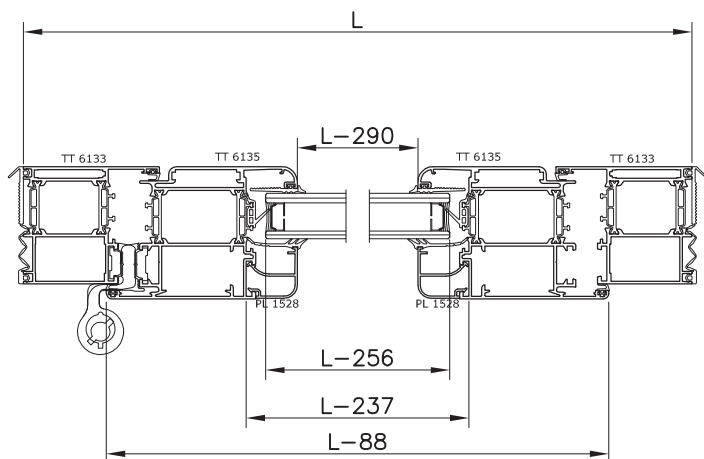

List of profiles

Item	description	pieces	size	cut
TT 6133	L frame crosspiece	1	L	
	L frame jamb	2	H	
TT 6135	leaf crosspiece	1	L-88	
	leaf jamb	2	H-49	
PL 1528	glazing bead crosspiece	2	L-290	
	glazing bead jamb	2	H-315	
TT 6141	base	1	L-237	

List of accessories

Item	description	qty
ACP 5018	two-wing hinge	3 pz
ACP 5802	multi-purpose bracket	4 pz
ACP 5008	alignment bracket	2 pz
ACP 50154	ext. crimping bracket	4 pz
ACP 5039	double handle	1 cp
ACP 50110	alignment bracket	2 pz
ACP 5035	nylon wall guide	6/8 pz
ACP 5014	nylon wall guide	4 pz
ACP 5001	screw for bracket	8 pz

List of gaskets

Item	description	pieces	size
AGP 4000	rebate	1	L-134
		1	L-88
		2	H-62
		2	H-44
AGP 4001	under glass	2	L-236
		2	H-261
AGP 4099	wall insulation	1	L
		2	H
depends on the glass	external glass	2	L-290
		2	H-315
depends on the glass	internal glass	2	L-290
		2	H-315

N.B. all the tables shown in our catalogues have been obtained using purely theoretical calculations and do not take extrusion tolerance, painting and machining into account; we therefore advise you to test them properly before producing

Open-in 2-leaf entrance door

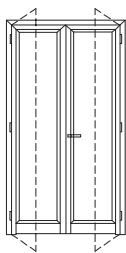

List of glass

No. of pieces	L	H
2	L/2-215	H-281

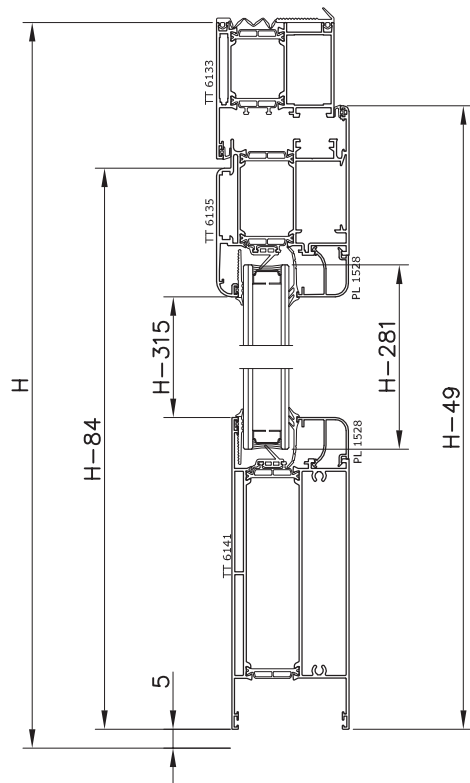
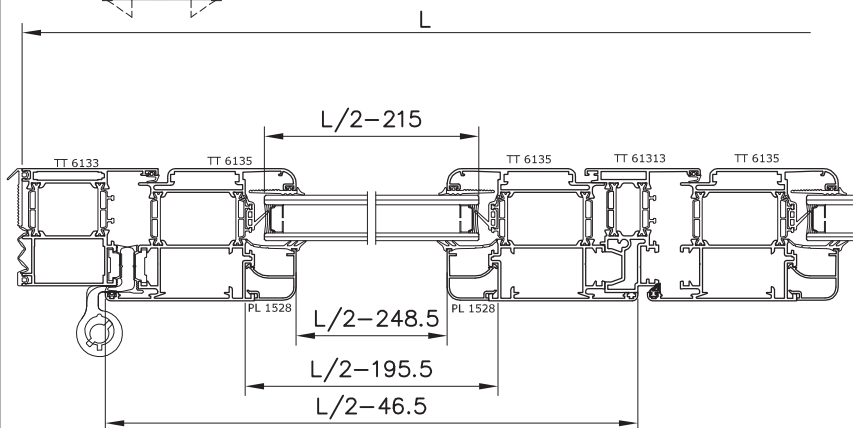

List of profiles

Item	description	pieces	size	cut
TT 6133	L frame crosspiece	1	L	
	L frame jamb	2	H	
TT 6135	leaf crosspiece	2	L/2-46.5	
	leaf jamb	4	H-49	
PL 1528	glazing bead crosspiece	4	L/2-248.5	
	glazing bead jamb	4	H-315	
TT 61313	central connection frame	1	H-84	
TT 6141	base	2	L/2-195.5	

List of gaskets

Item	description	pieces	size
AGP 4000		2	L/2-46.5
		1	L-124
		6	H-49
AGP 4001		4	L/2-196.5
		4	H-261
AGP 4099		1	L
		2	H
depends on the glass		4	L/2-248.5
		4	H-315
depends on the glass		4	L/2-248.5
		4	H-315
AGP 4005		1	H-84

List of accessories

Item	description	qty
ACP 5802	multi-purpose bracket	6 pz
ACP 5008	stainless steel align. bracket	4 pz
ACP 50110	eccentric align. bracket	4 pz
ACP 50154	ext. crimping bracket	6 pz
ACP 5039	double handle doors	1 cp
ACP 5022	latch	1 cp
ACP 5081	rod striker	1 pz
ACP 5035	nylon wall guide	6/8 pz
ACP 5014	glazing bead angles	8 pz
ACP 62178	connection profile cap	1 cp
ACP 5018	two-wing hinge	6 pz
ACP 5001	screw for bracket	12 pz

N.B. All the tables shown in our catalogues have been obtained using purely theoretical calculations and do not take extrusion tolerance, painting and machining into account; we therefore advise you to test them properly before producing

Open-out 2-leaf entrance door

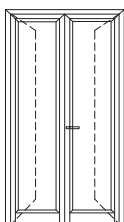

List of glass

No. of pieces	L	H
2	L/2-229	H-288

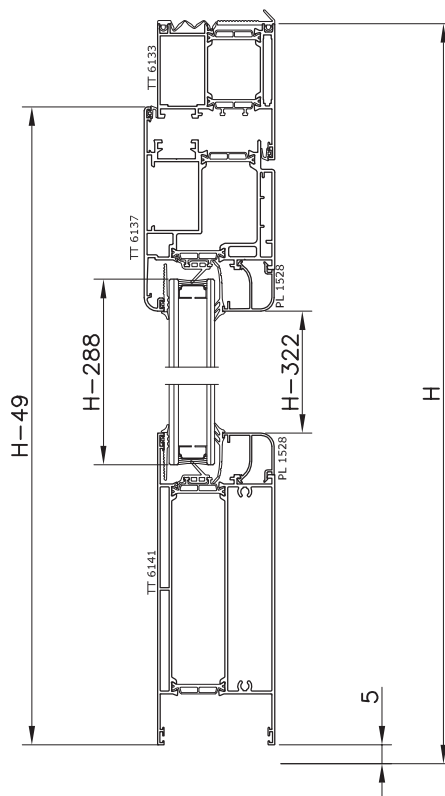
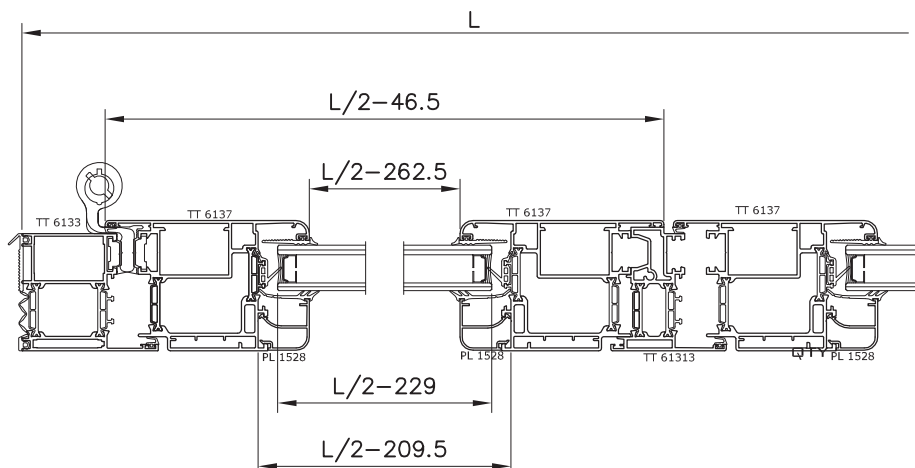

List of profiles

Item	description	pieces	size	cut
TT 6133	L frame crosspiece	1	L	
	L frame jamb	2	H	
TT 6137	leaf crosspiece	2	L/2-46.5	
	leaf jamb	4	H-49	
PL 1528	glazing bead crosspiece	4	L/2-262.5	
	glazing bead jamb	4	H-322	
TT 61313	central connection frame	1	H-84	
TT 6141	base	2	L/2-209.5	

List of accessories

Item	description	qty
ACP 5802	multi-purpose bracket	6 pz
ACP 5008	stainless steel align. bracket	4 pz
ACP 50110	eccentric align. bracket	4 pz
ACP 50154	ext. crimping bracket	6 pz
ACP 5039	double handle doors	1 cp
ACP 5022	latch	1 cp
ACP 5081	rod striker	1 pz
ACP 5035	nylon wall guide	6/8 pz
ACP 5014	glazing bead angles	8 pz
ACP 62178	connection profile cap	1 cp
ACP 5018	two-wing hinge	6 pz
ACP 5001	screw for bracket	12 pz

List of gaskets

Item	description	pieces	size
AGP 4000		2	L/2-46.5
		1	L/2-124
		6	H-44
AGP 4001		4	L/2-208.5
		4	H-261
AGP 4099		1	L
		2	H
depends on the glass		4	L/2-262.5
		4	H-315
depends on the glass		4	L/2-262.5
		4	H-315
AGP 4005		1	H-84

N.B. All the tables shown in our catalogues have been obtained using purely theoretical calculations and do not take extrusion tolerance, painting and machining into account; we therefore advise you to test them properly before producing

Horizontal pivot

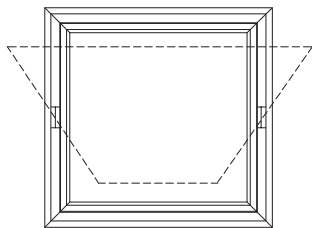

List of glass

No. of pieces	L	H
1	L-276	H-276

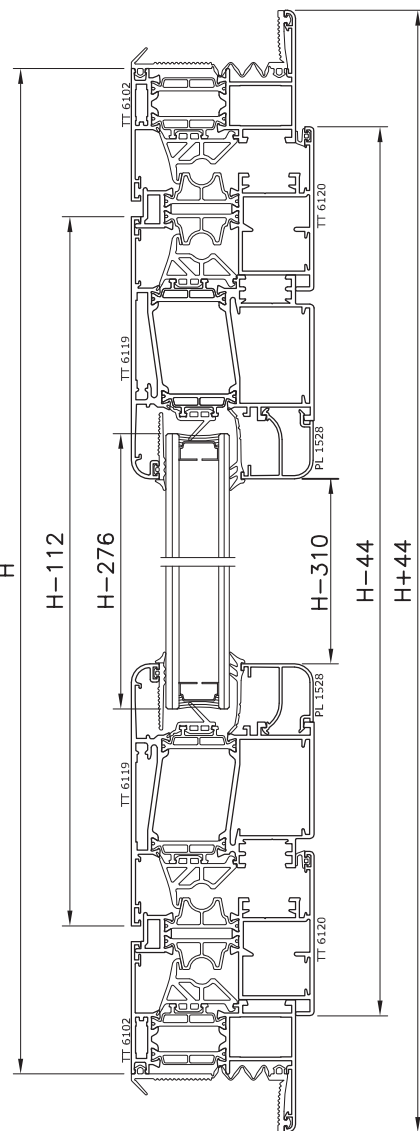
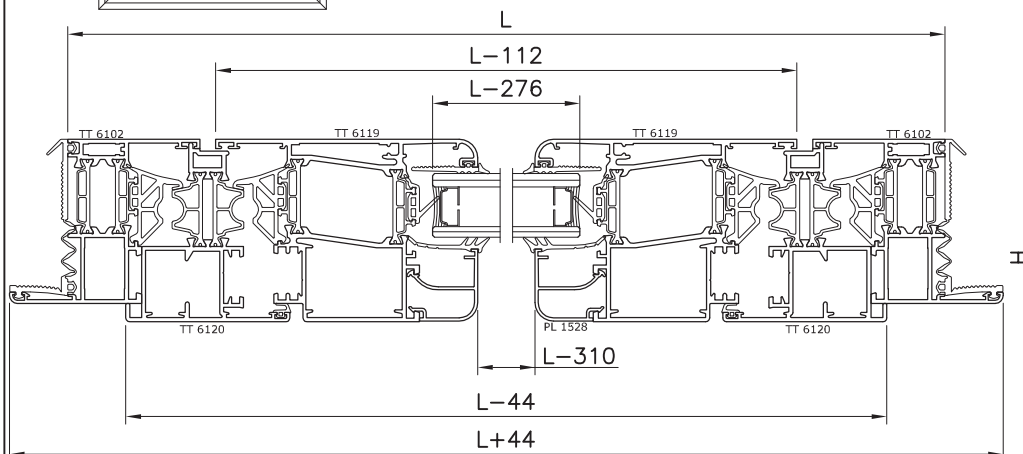

List of profiles

Item	description	pieces	size	cut
TT 6102	frame crosspiece	2	L+44	
	frame jamb	2	H+44	
TT 6119	leaf crosspiece	2	L-112	
	leaf jamb	2	H-112	
PL 1528	glazing bead crosspiece	2	L-310	
	glazing bead jamb	2	H-310	
TT 6120	reversal crosspiece	2	L-44	
	reversal jamb	2	H-44	

List of gaskets

Item	description	pieces	size
AGP 4000	rebate	2 2	H-44 L-44
AGP 4001	under glass	2 2	L-256 H-256
AGP 4099	wall insulation	2 2	L H
AGP 6272	open joint fin	2	L-144
		2	H-144
		2	L-112
		2	H-112
depends on the glass	external glass	2 2	L-256 H-256
depends on the glass	internal glass	2 2	L-256 H-256

List of accessories

Item	description	qty
ACP 5801	multi-purpose bracket	8 pz
ACP 5008	stainless steel align. bracket	12 pz
ACP 50110	eccentric align. bracket	4 pz
ACP 50153	ext. crimping bracket	4 pz
ACP 50154	ext. crimping bracket	4 pz
ACP 5035	nylon wall guide	6/8 pz
ACP 5014	glazing bead angles	4 pz
ACP 5090	pivot friction joint	2 pz
ACP 5802	multi-purpose bracket	4 pz
AGP 6285	vulcanised corner	4 pz
ACP 5088	horiz. pivot 4 point closure kit	1 kit
ACP 5001	screw for bracket	24 pz

N.B. all the tables shown in our catalogues have been obtained using purely theoretical calculations and do not take extrusion tolerance, painting and machining into account; we therefore advise you to test them properly before producing

2-leaf tilt and turn single unit

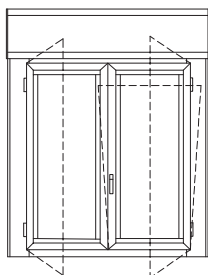

List of glass

No. of pieces	L	H
2	L/2-128.5	H-148

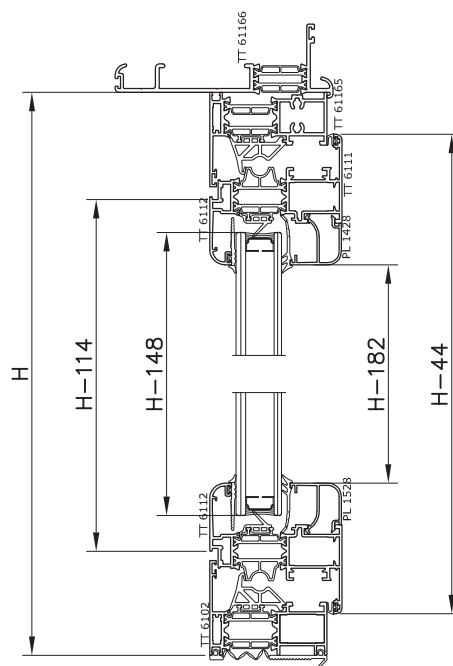
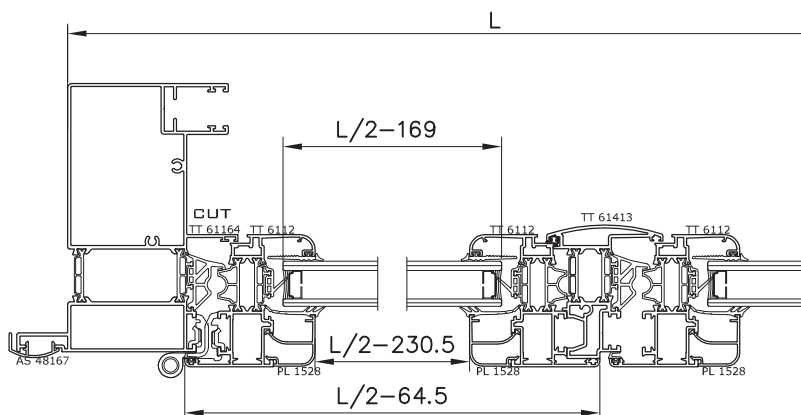

List of profiles

Item	description	pieces	size	cut
TT 6103	lower frame crosspiece	1	L-128	
TT 61165	upper frame crosspiece	1	L-128	
TT 61164	frame jamb	2	H	
TT 6112	leaf crosspiece	4	L/2-64.5	
	leaf jamb	4	H-44	
PL 1528	glazing bead crosspiece	4	L/2-230.5	
	glazing bead jamb	4	H-182	
TT 61413	central connection frame	1	H-114	
TT 61166	single-unit top cover	1	L	

List of accessories

Item	description	qty
ACP 5801	multi-purpose bracket	8 pz
ACP 5008	stainless steel align. bracket	8 pz
ACP 50110	eccentric align. bracket	8 pz
ACP 50153	ext. crimping bracket	8 pz
ACP 5043	tilt leaf hinge kit	1 kit
ACP 5050	tilt leaf kit	1 kit
ACP 5052	latch kit	1 kit
ACP 5035	nylon wall guide	6/8 pz
ACP 5014	glazing bead angles	8 pz
ACP 62179	connection profile cap	1 cp
AGP 6285	vulcanised corner	4 pz
ACP 5046/	tilt leaf arm	1 pz
ACP 5001	screw for bracket	16 pz

List of gaskets

Item	description	pieces	size
AGP 4000		rebate	4
			3
AGP 4001		under glass	4
			4
AGP 6272		open joint fin	2
			2
depends on the glass		external glass	4
			4
depends on the glass		internal glass	4
			4
AGP 4099		1	L
AGP 4006		1	H-114

N.B. all the tables shown in our catalogues have been obtained using purely theoretical calculations and do not take extrusion tolerance, painting and machining into account; we therefore advise you to test them properly before producing

Open-in –casement window – lateral node

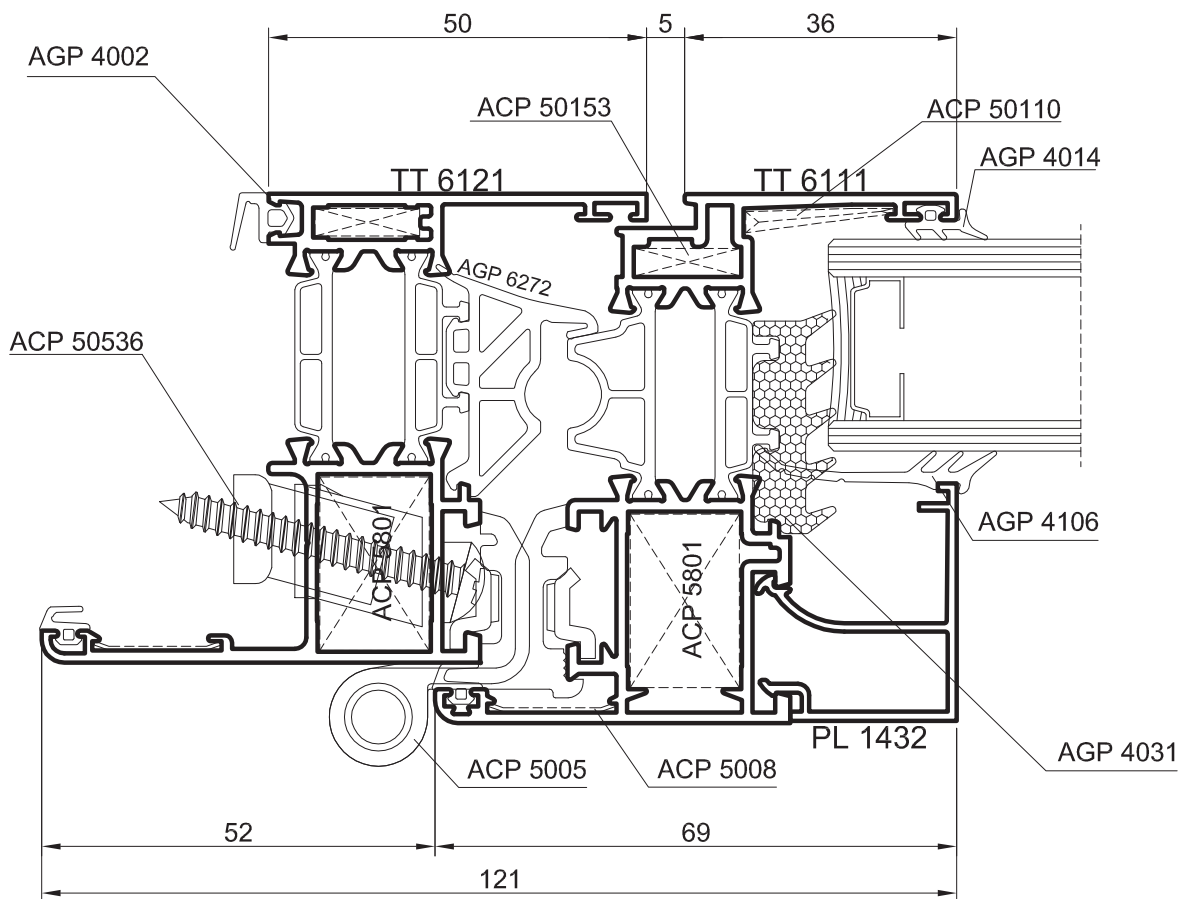
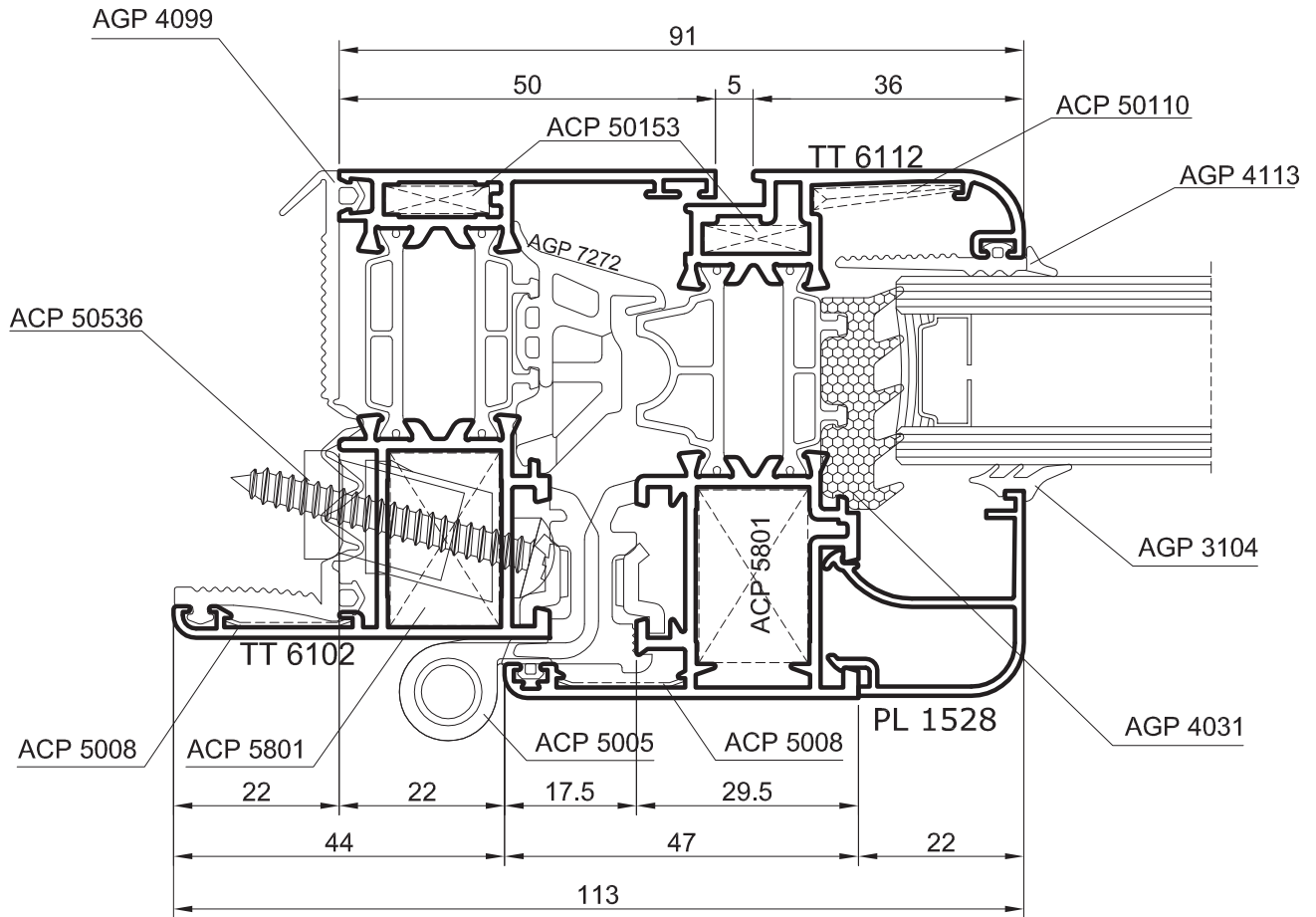

Open-in –casement window – lateral node

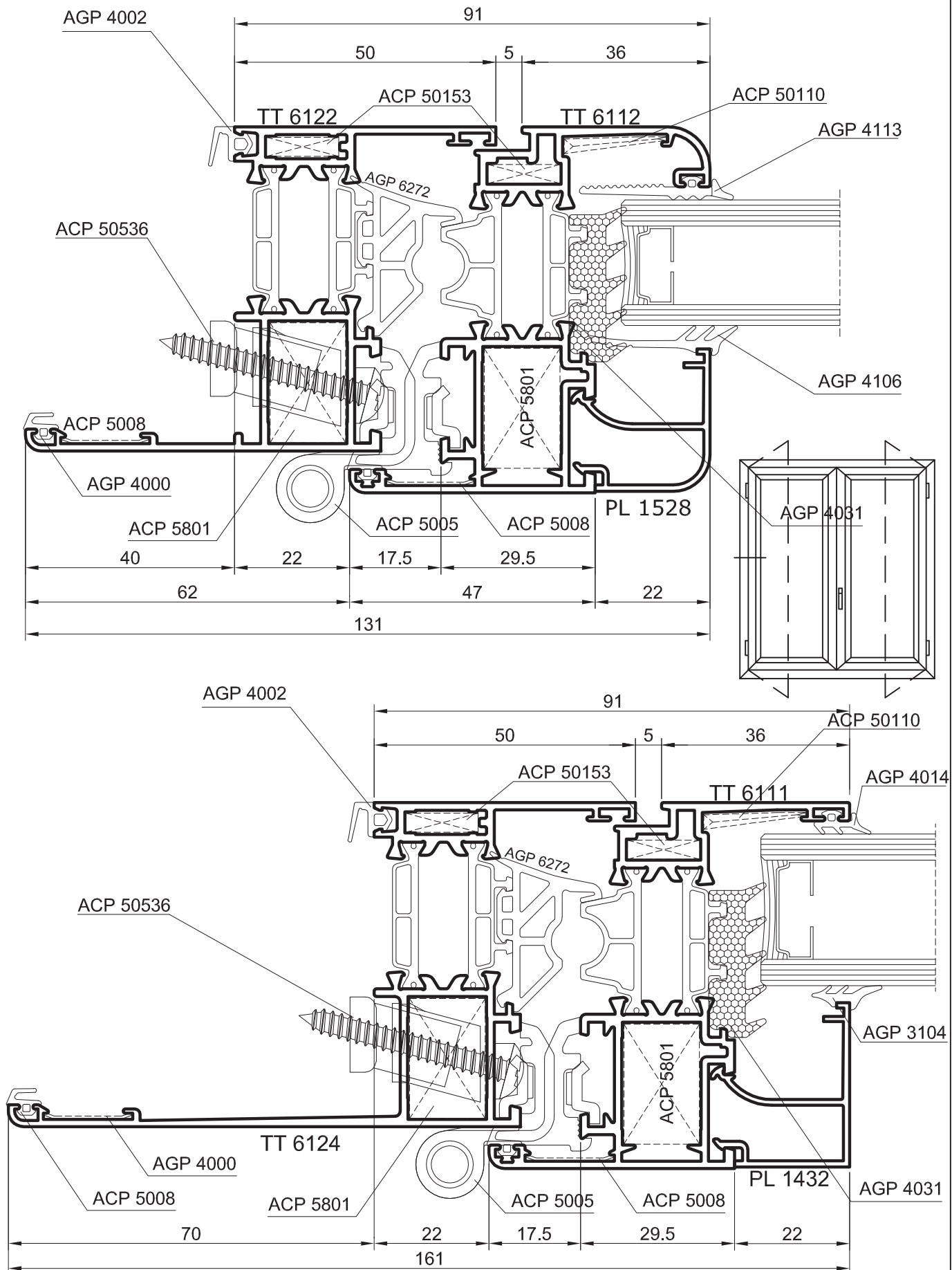

Open-in –casement window – lateral node- sect. 65mm

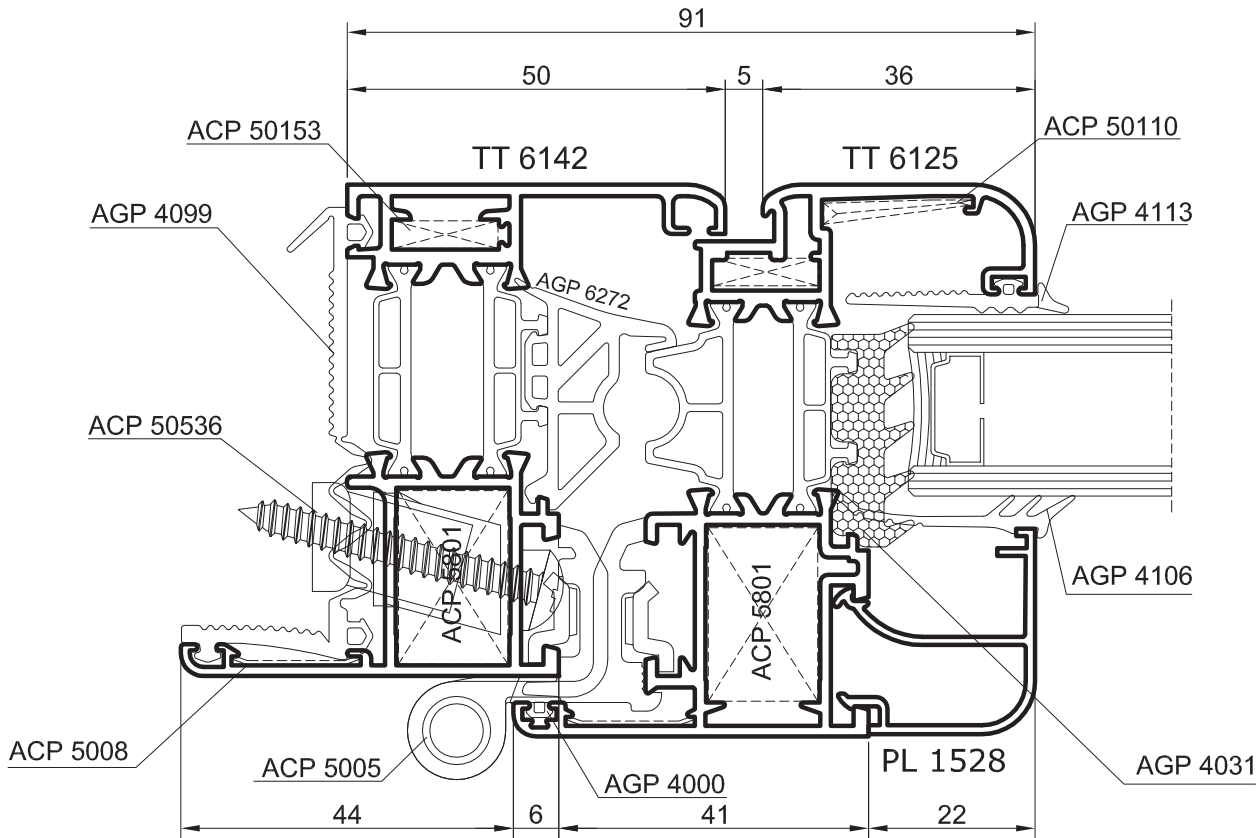

Open-in –casement window – lateral node

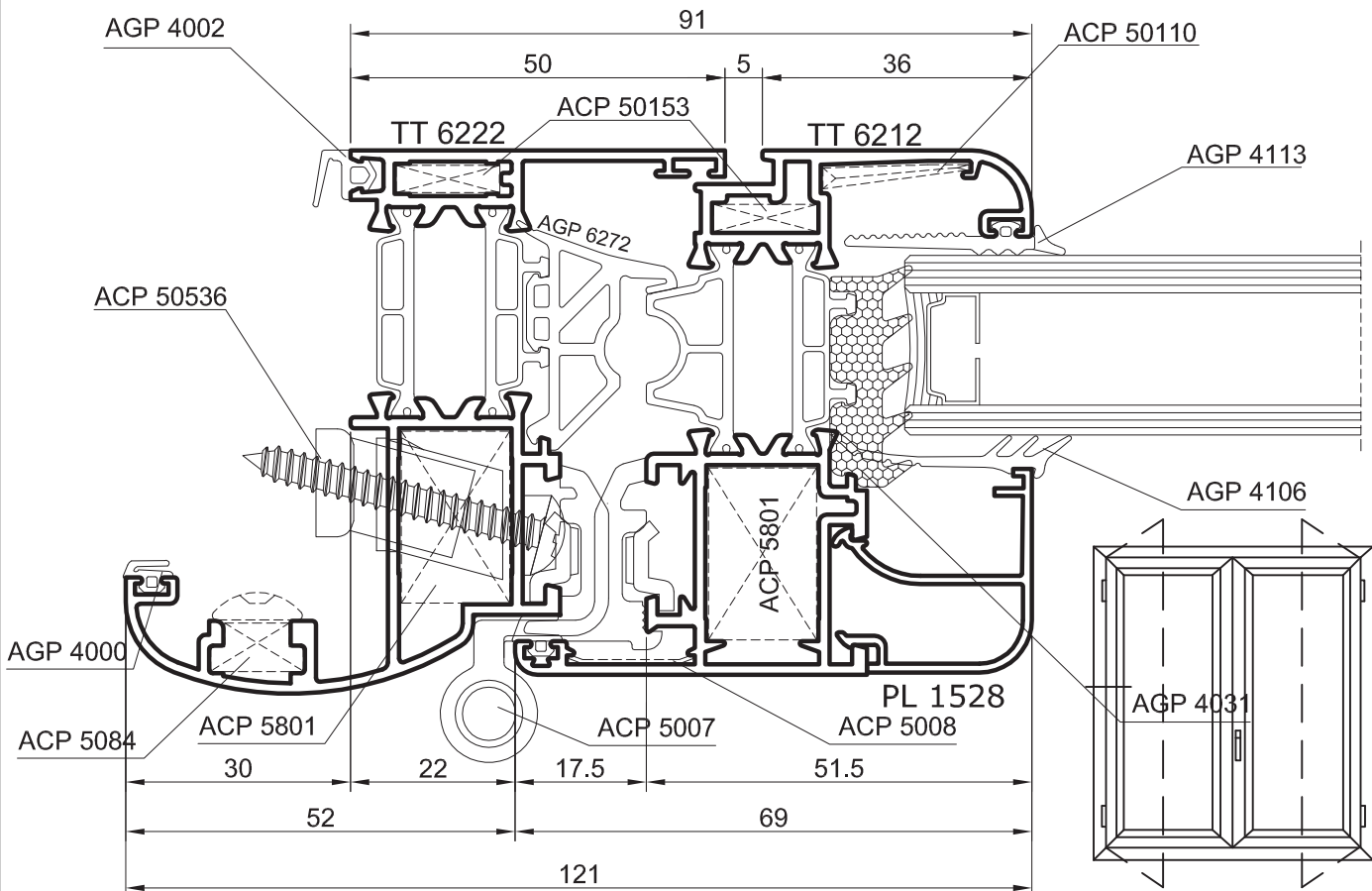

Open-in –casement window – lateral node

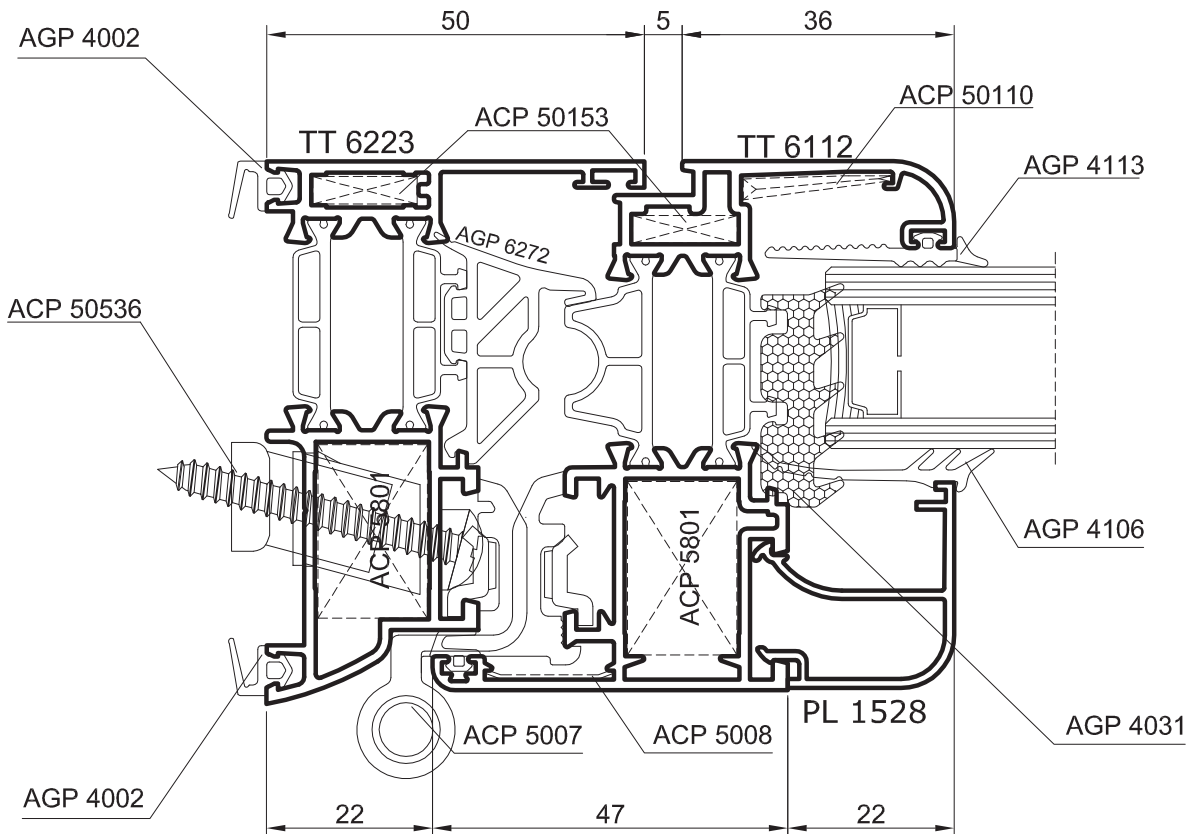
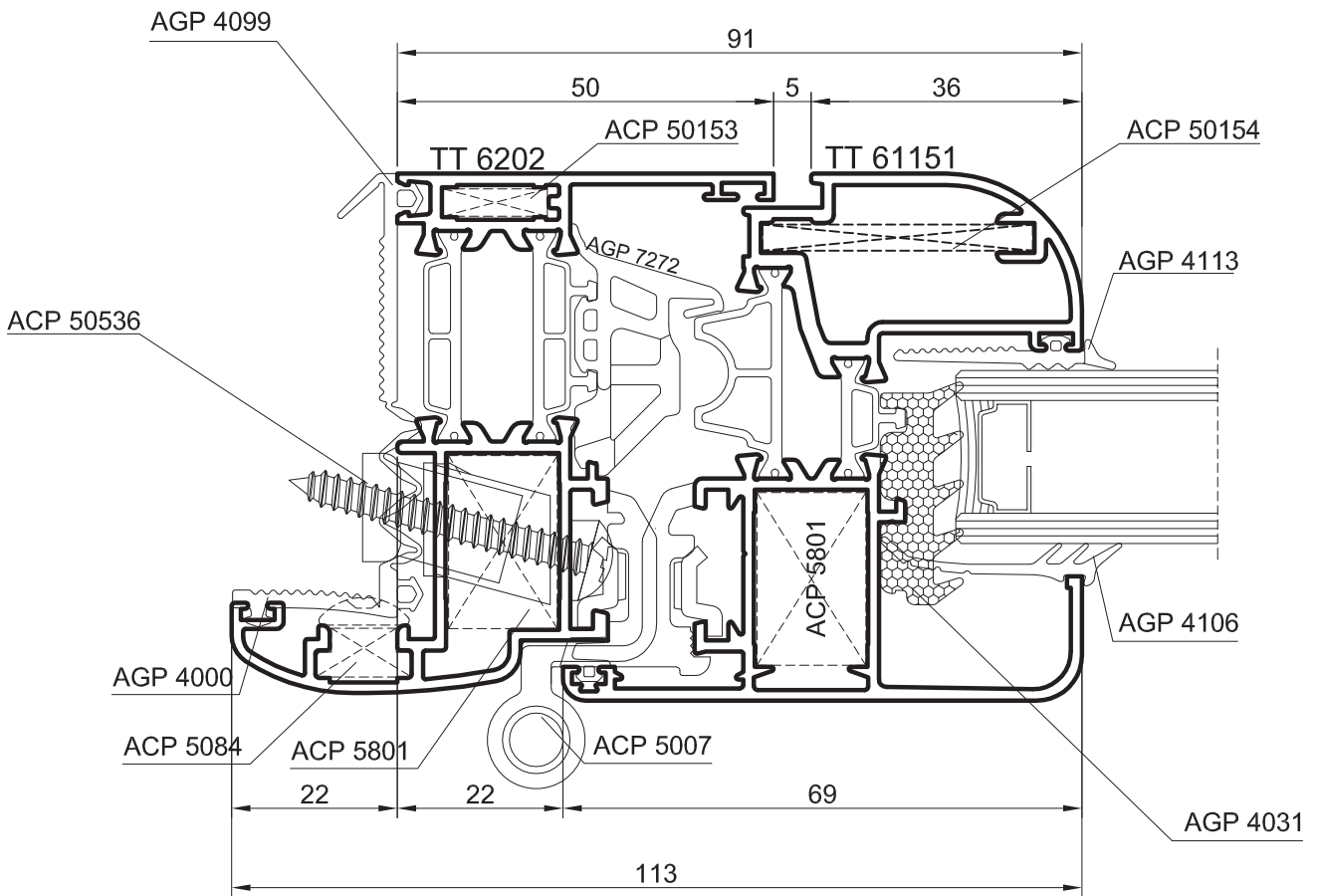

Open-in –casement window – lateral node- sect. 67mm

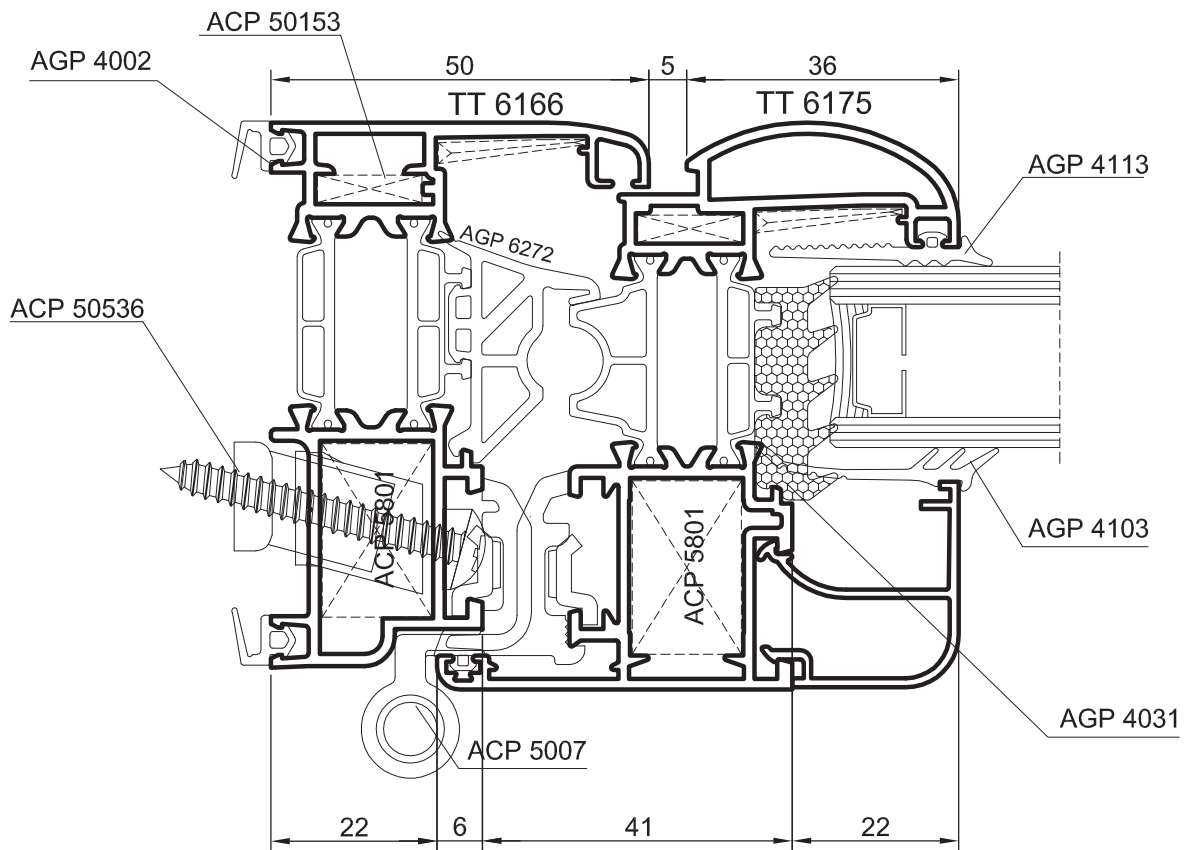
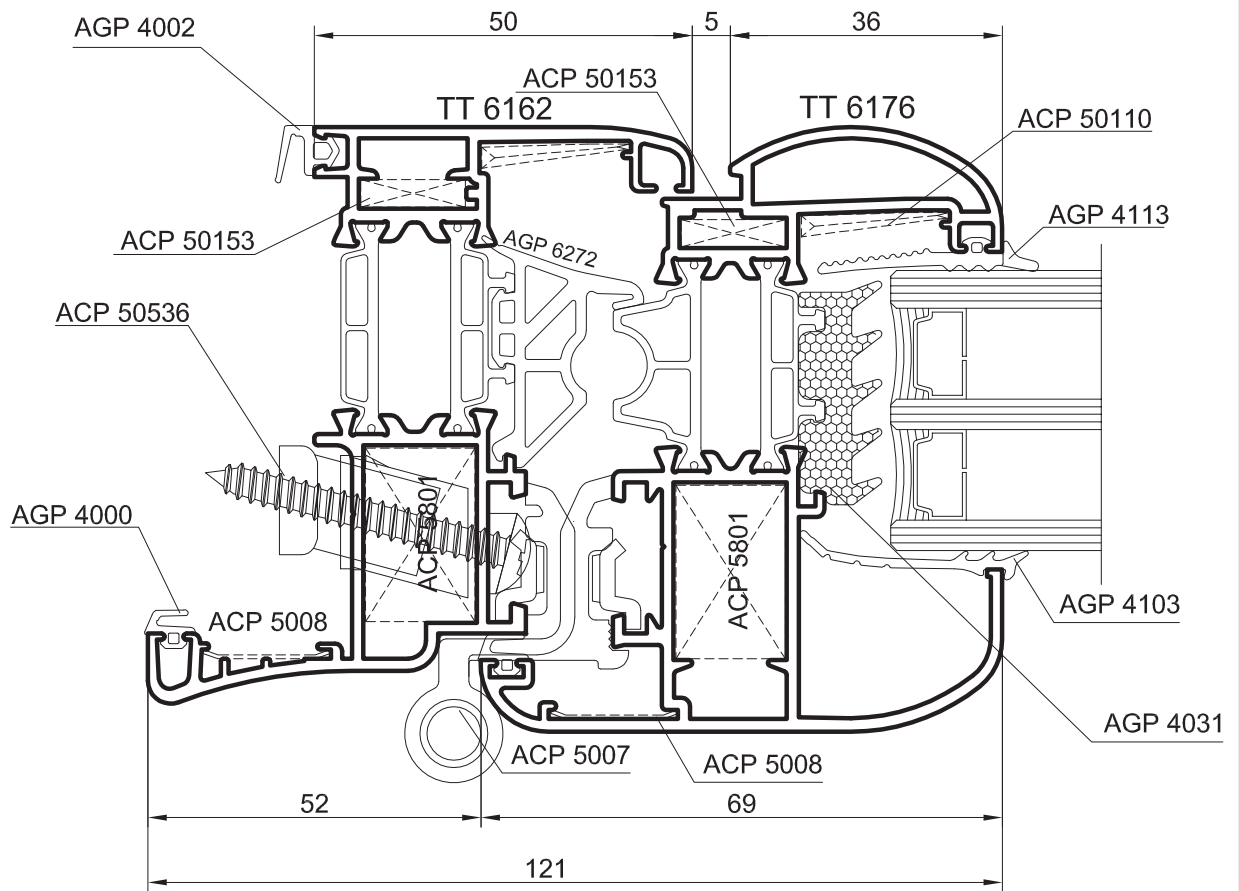

Open-in –casement window – lateral node

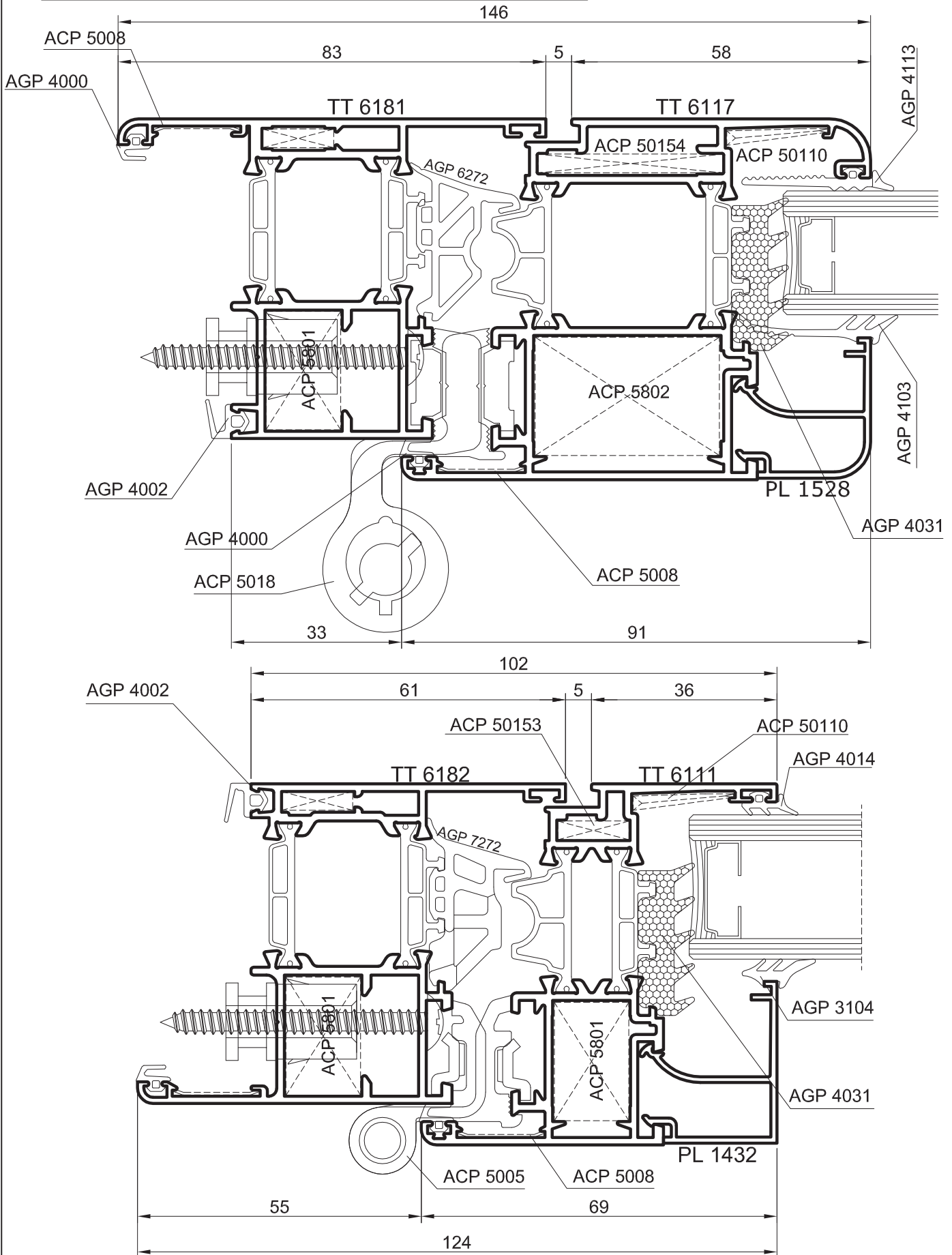

Open-in –casement window – lateral node

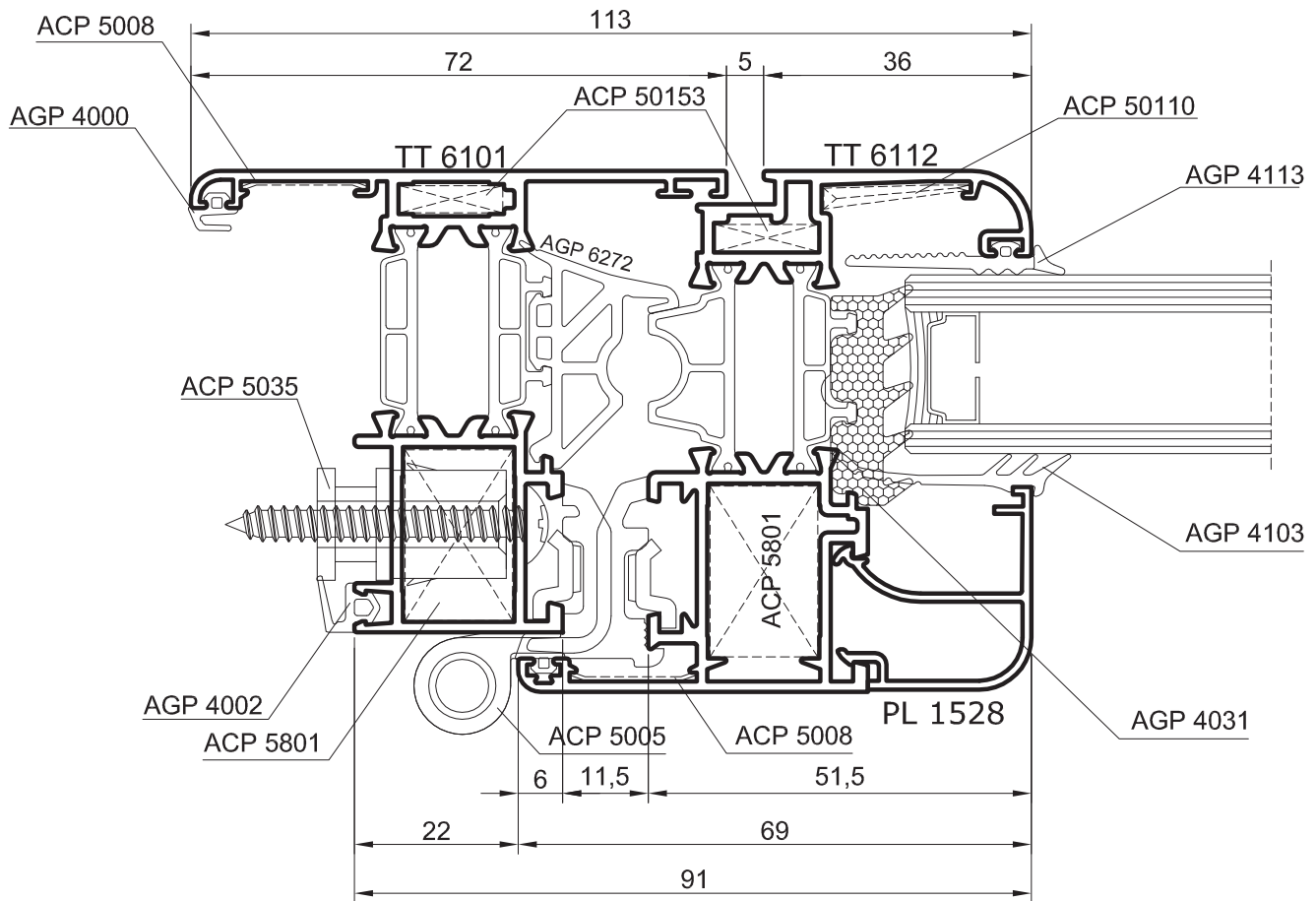

Open-in –tilt window – lateral node

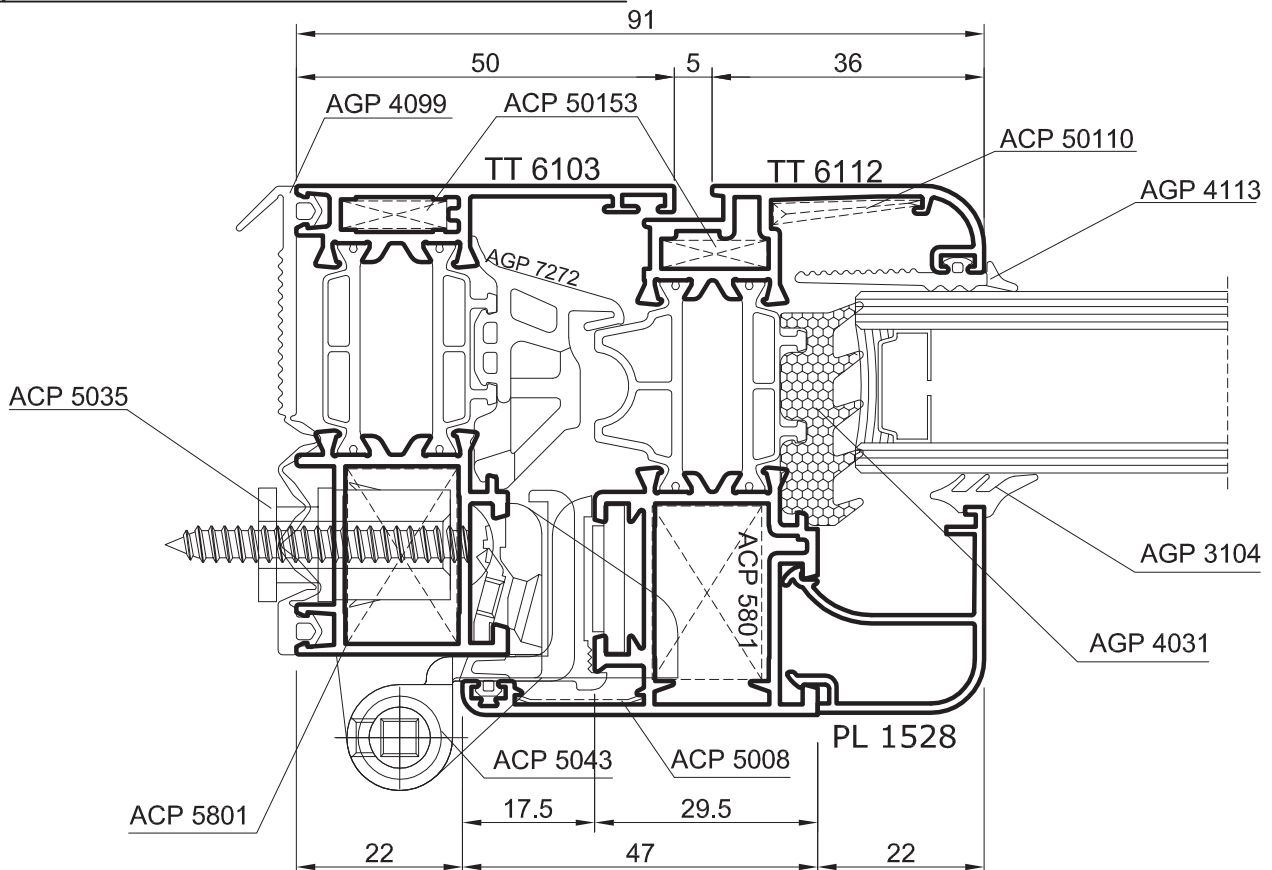

Open-out –casement window – lateral node

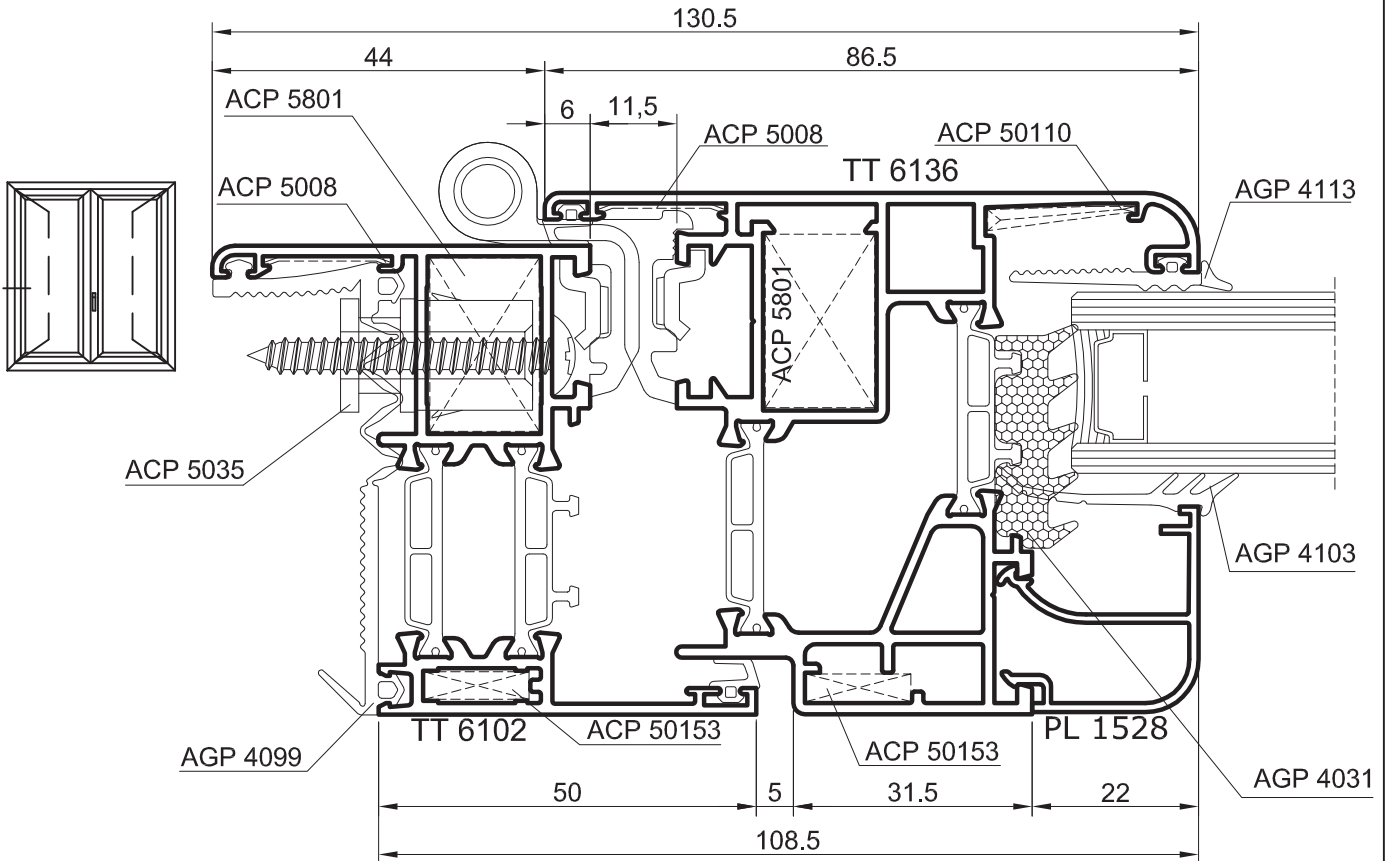

Top-hinged opening – perimeter node

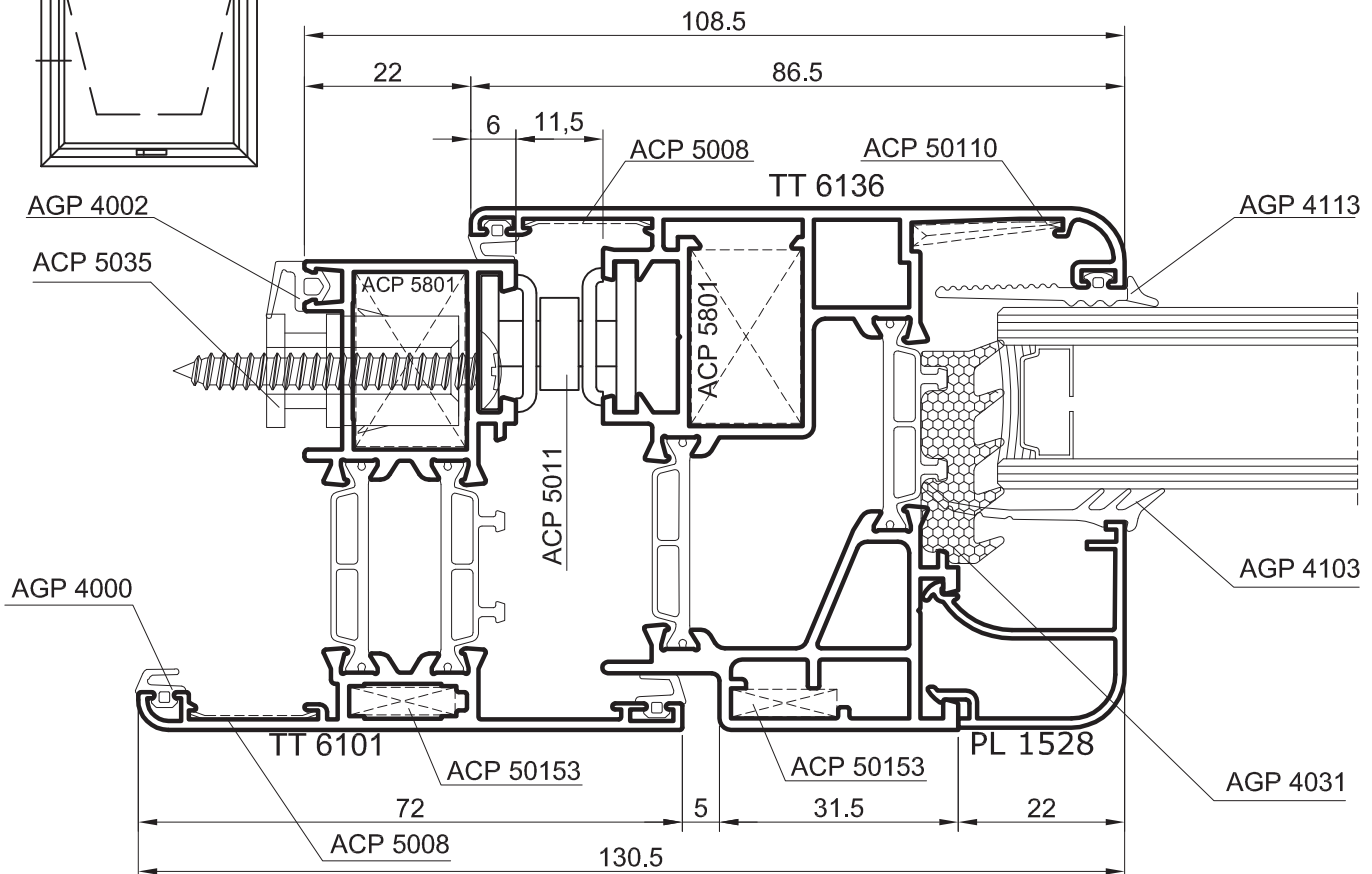

Open-out –casement door – lateral node

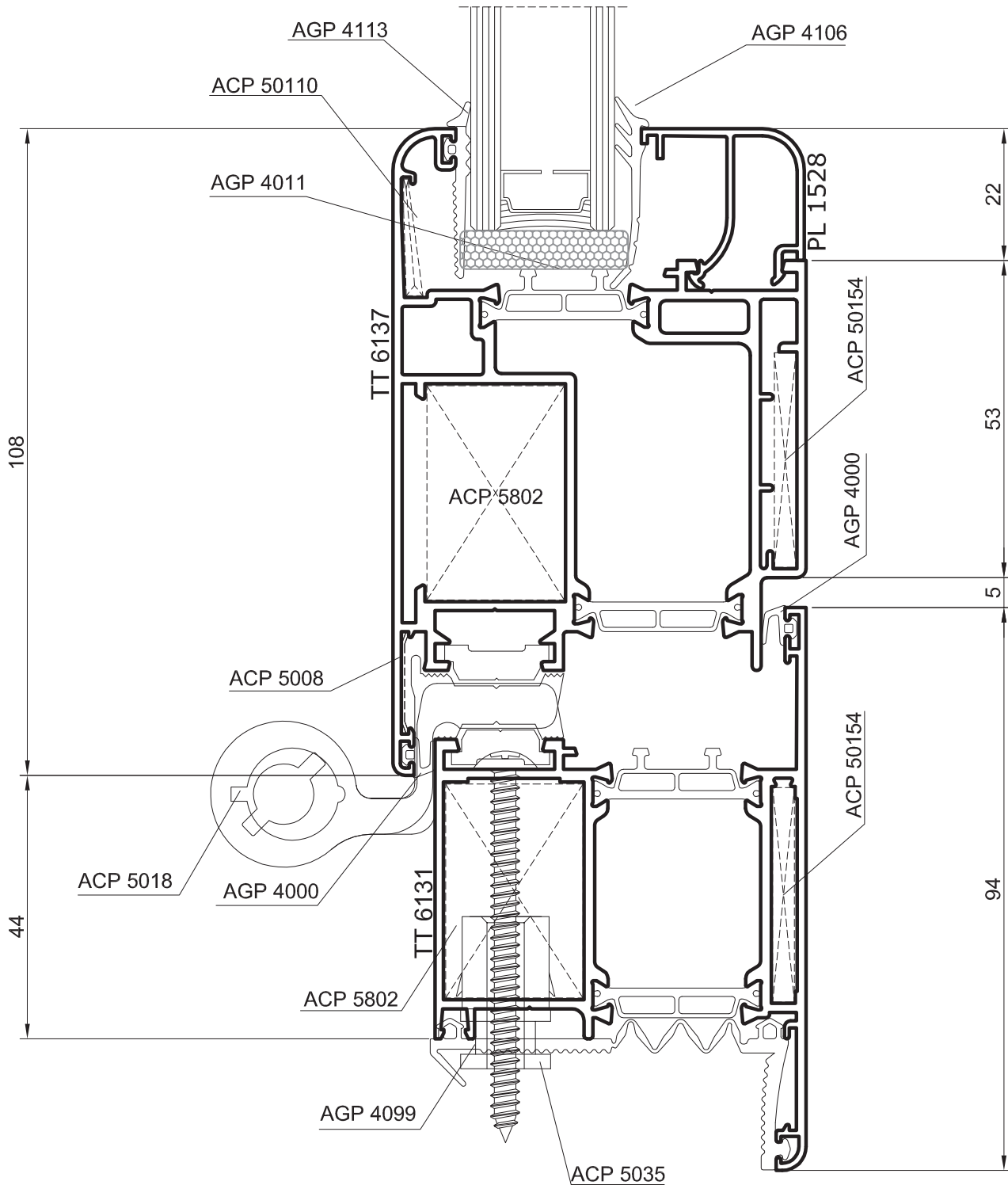

Open-in –casement door – lateral node

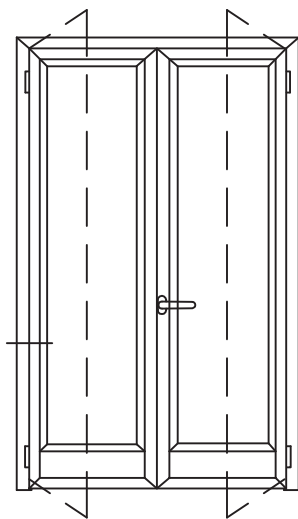
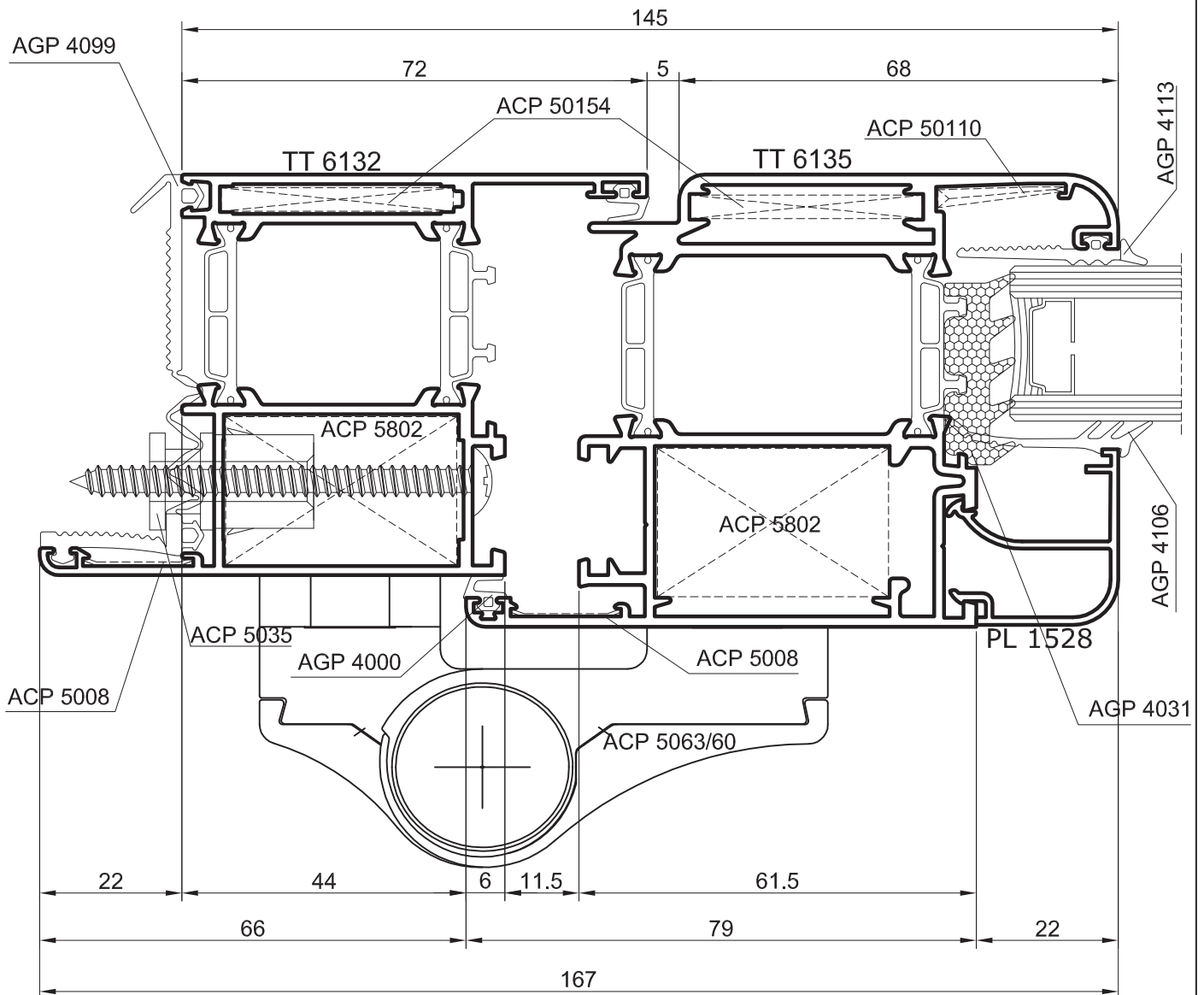

Open-in –casement door – lateral node

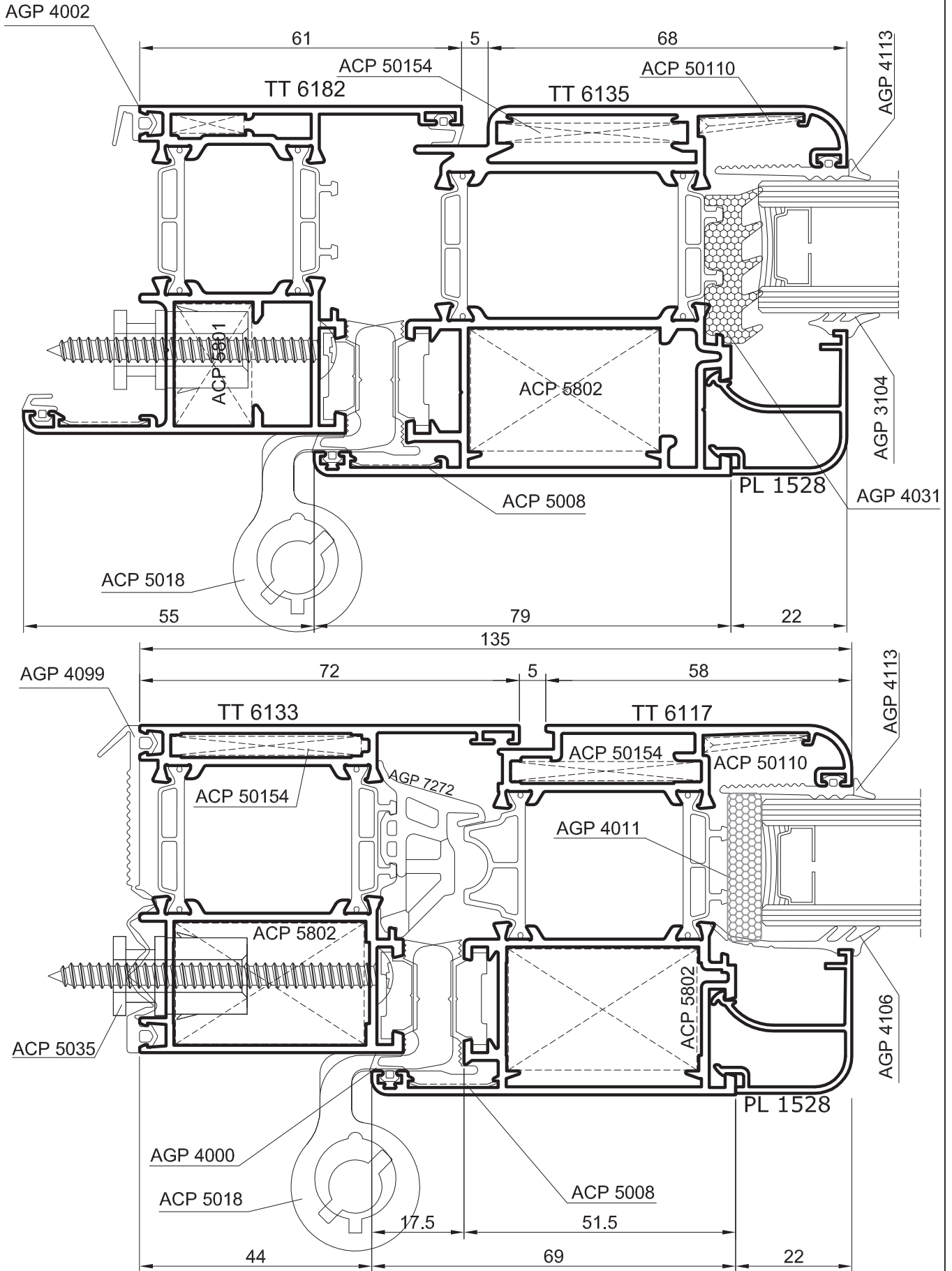

Open-out – casement door with glass - joint node

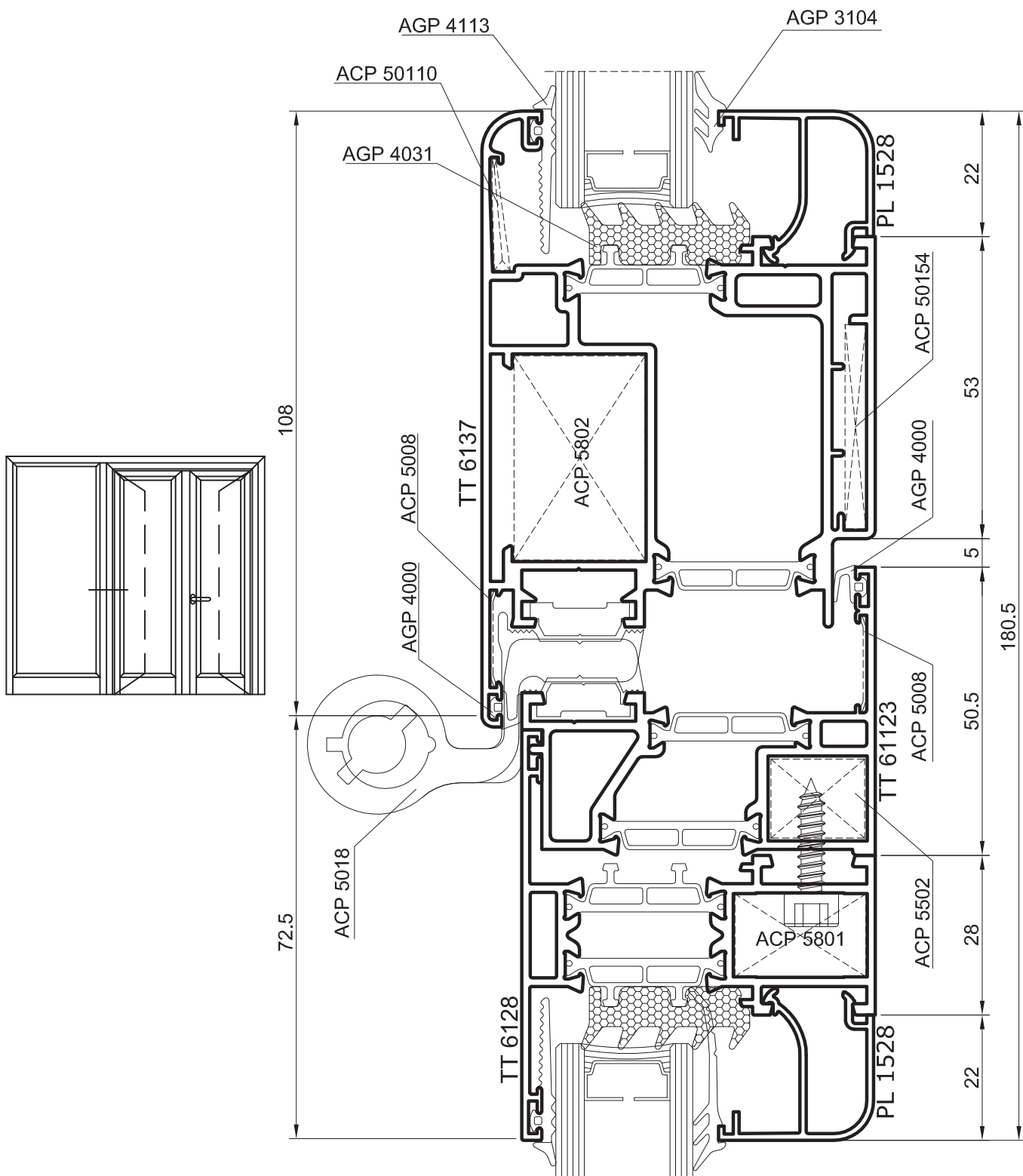

Open-out – casement door with glass - joint node

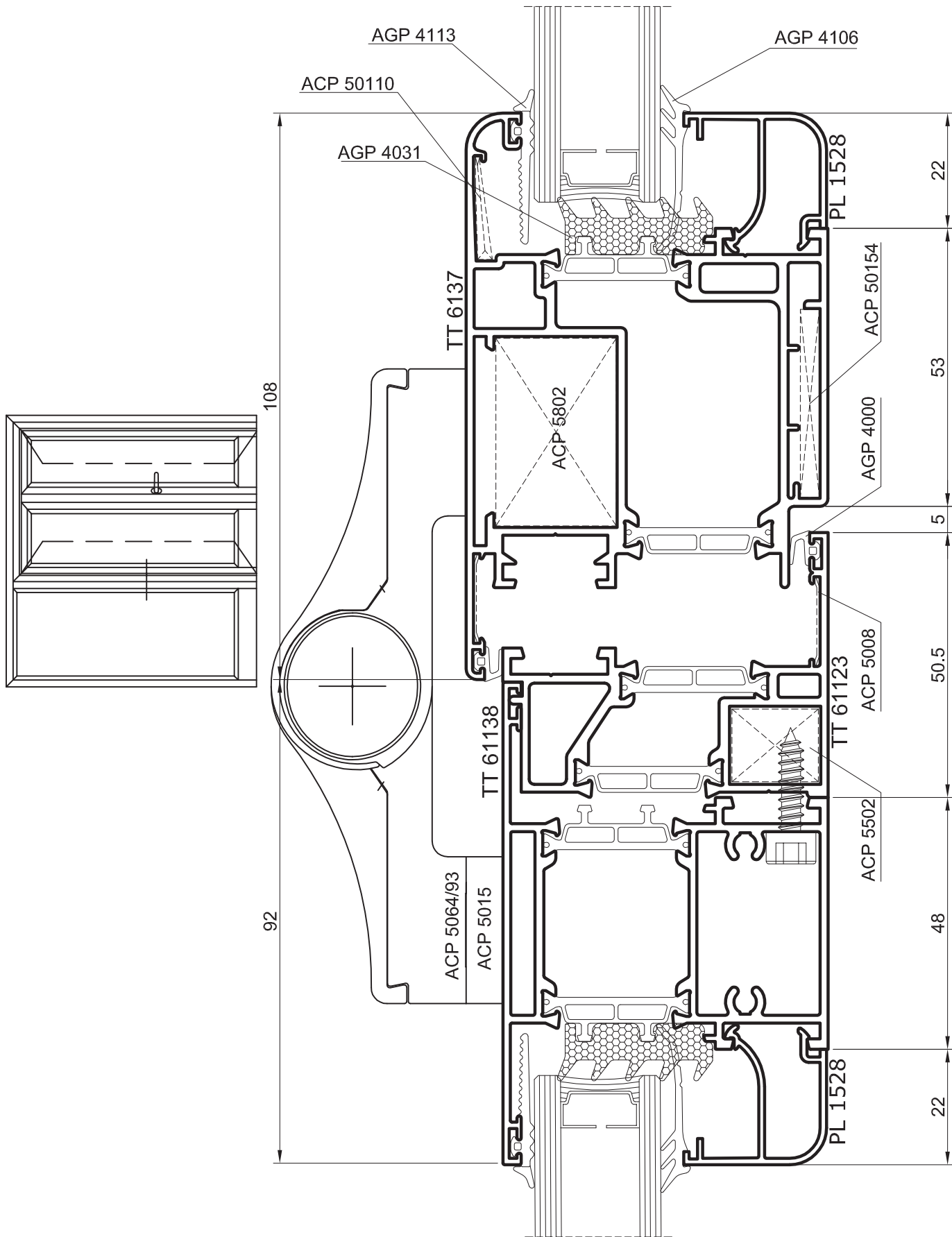

Open-out –casement door with window– lateral node

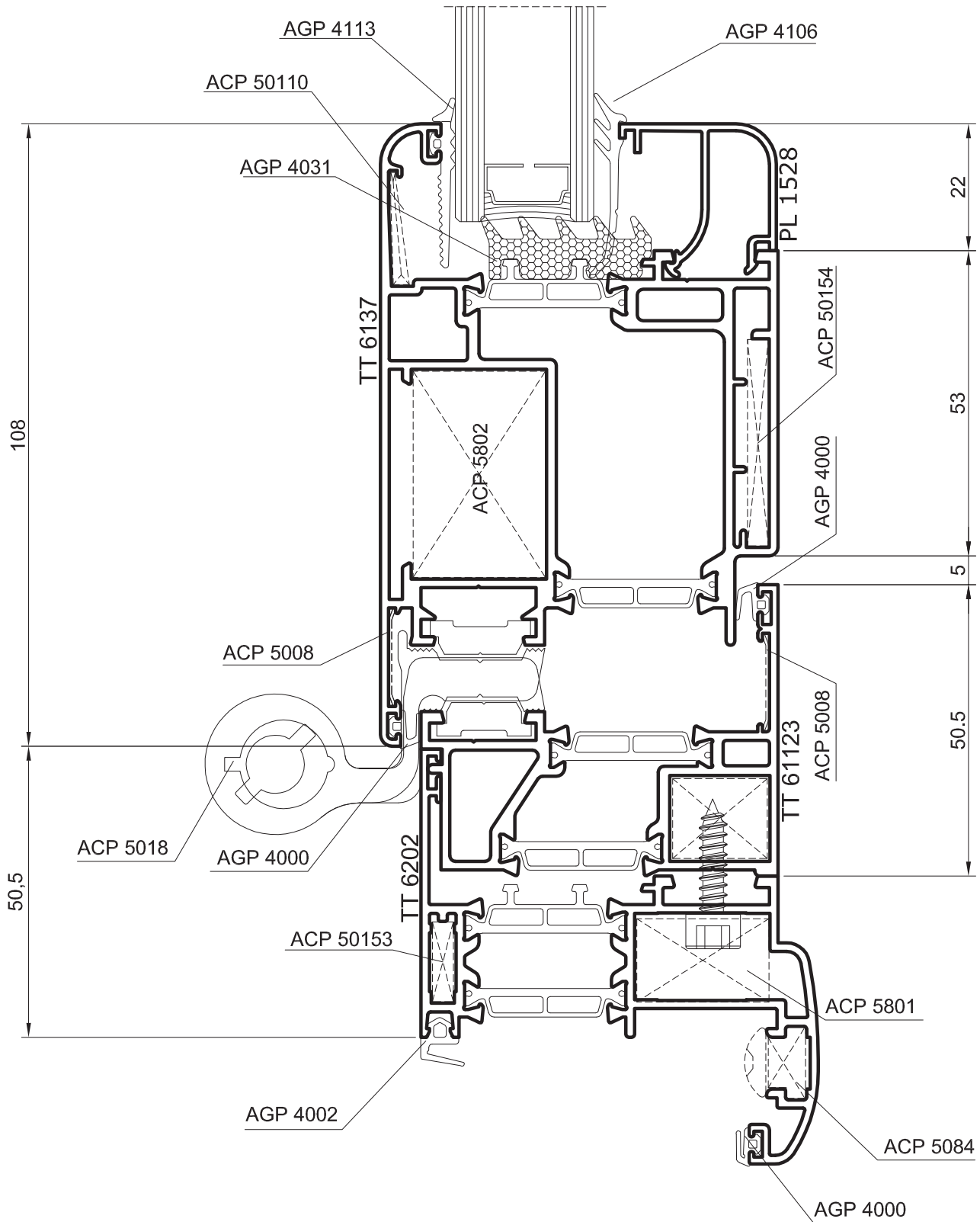

Open-in –casement window – sill node

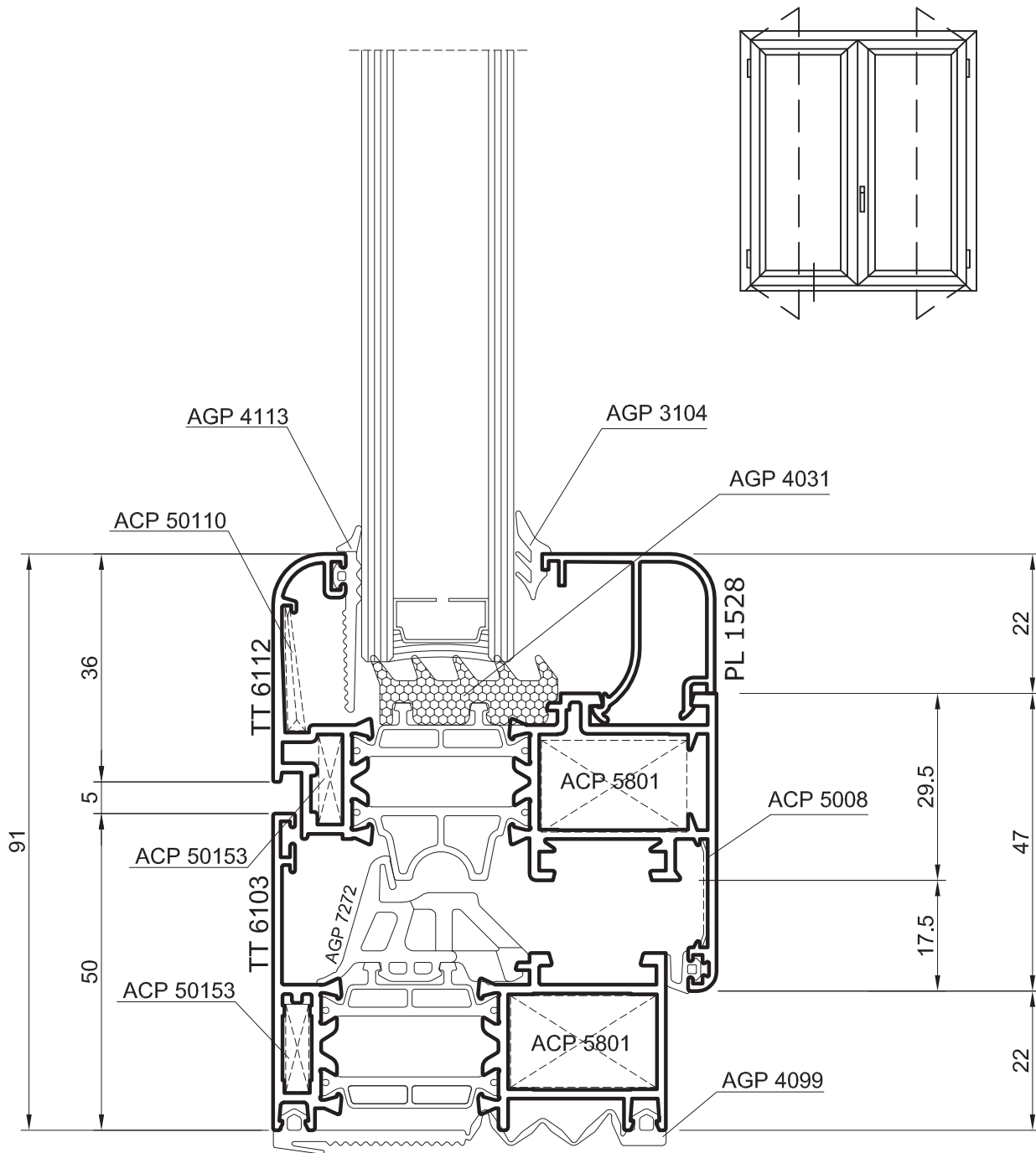

Open-in – glass door – threshold node

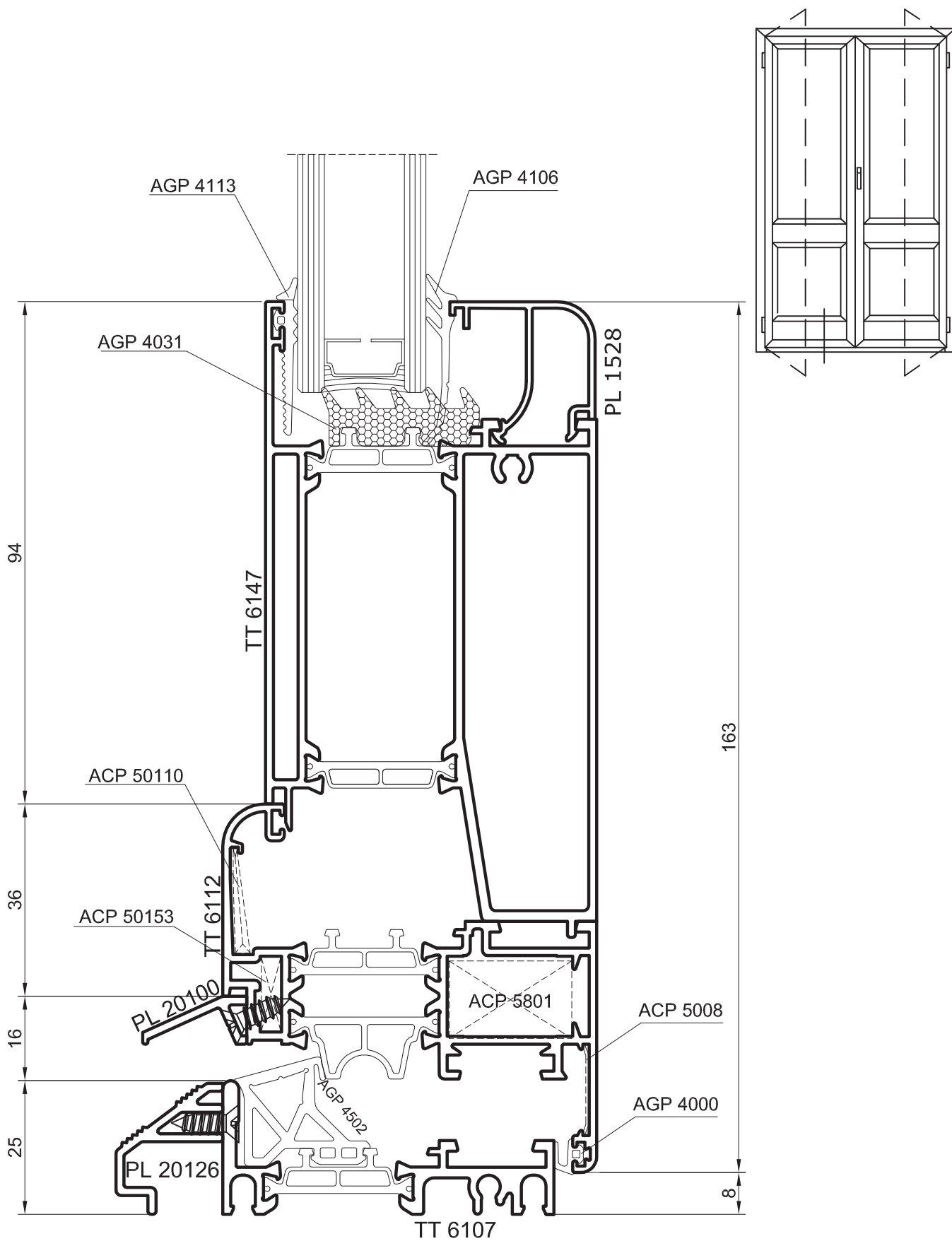

Open-in – glass door – threshold node

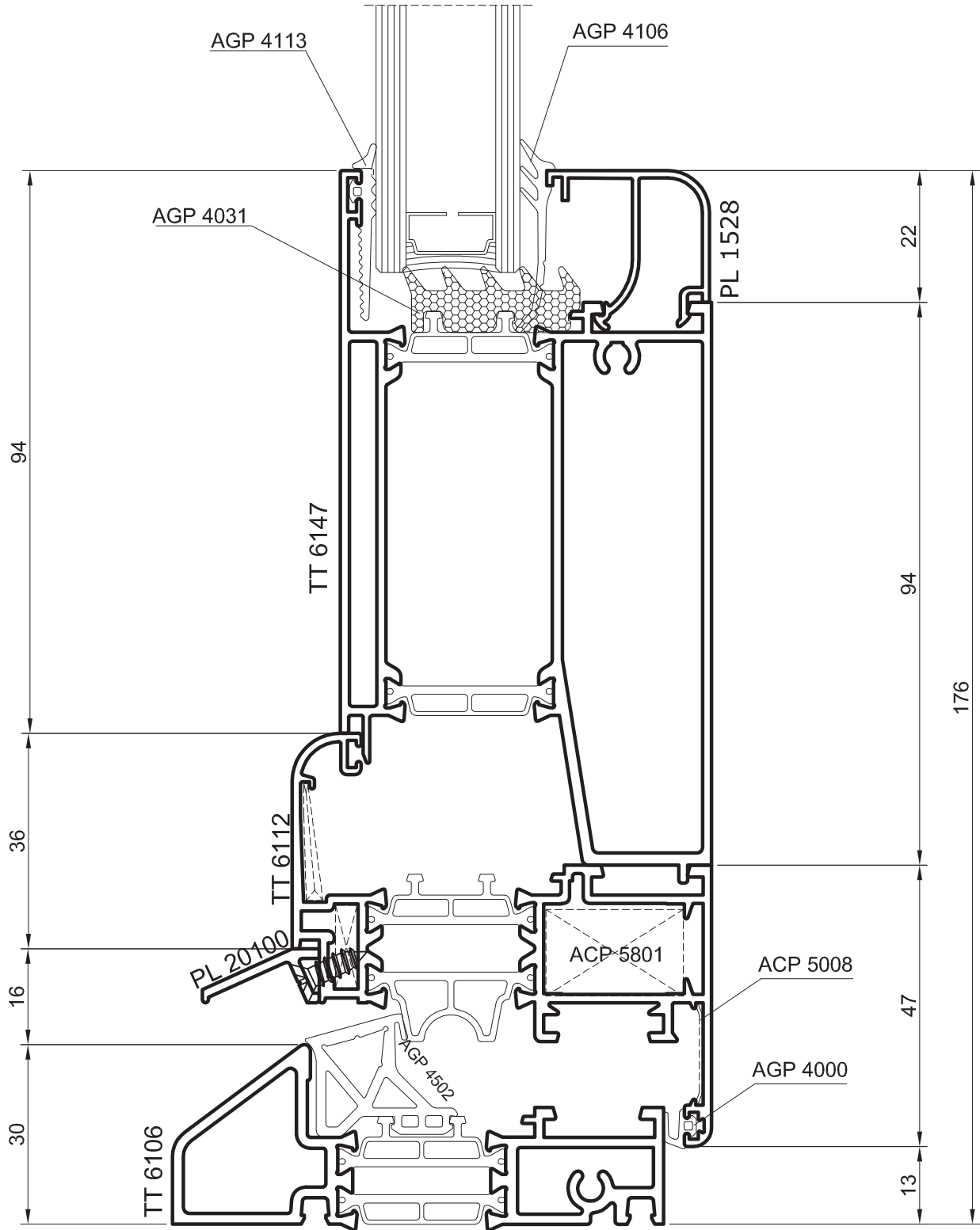

Open-in – casement window – sill node

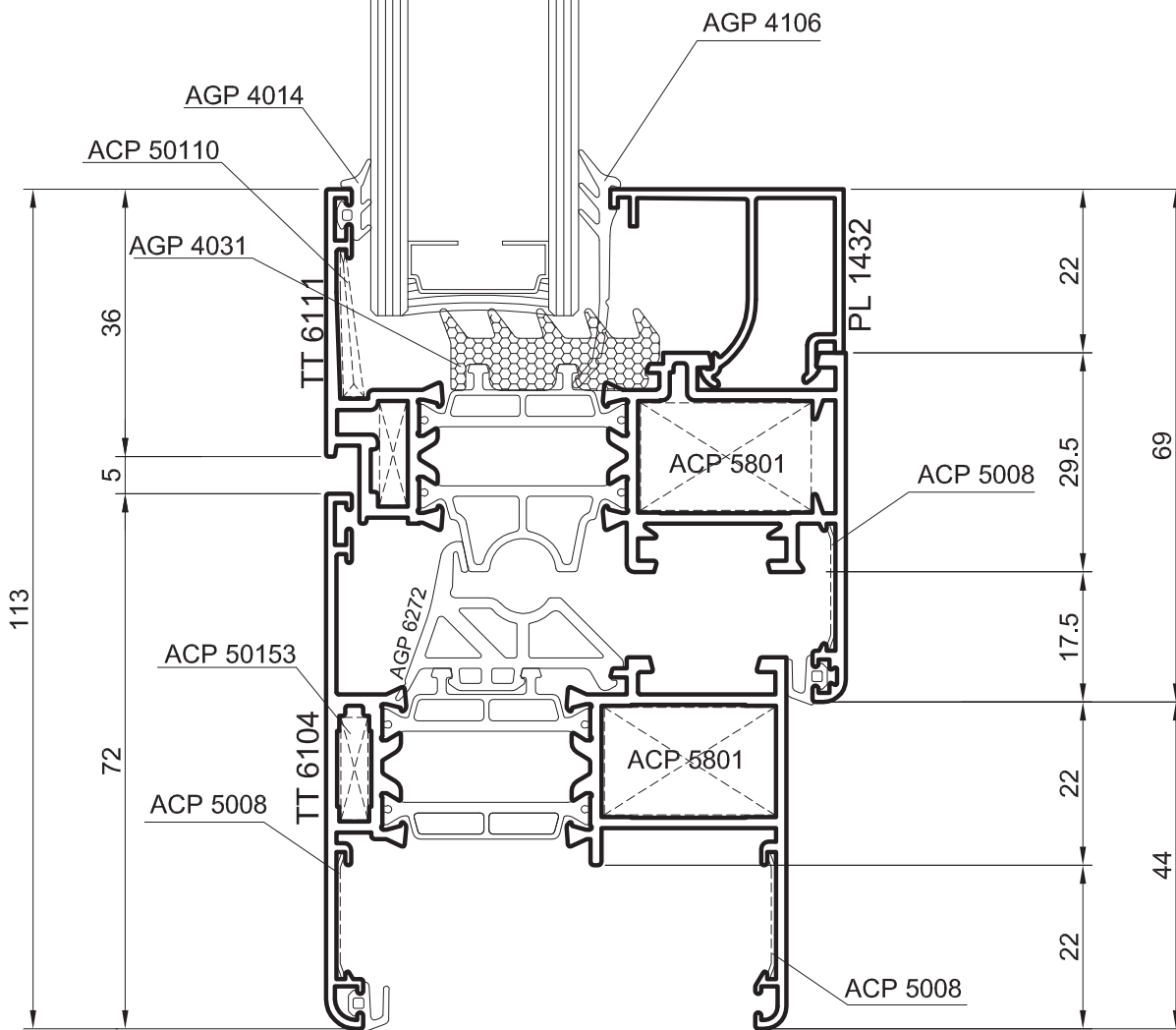
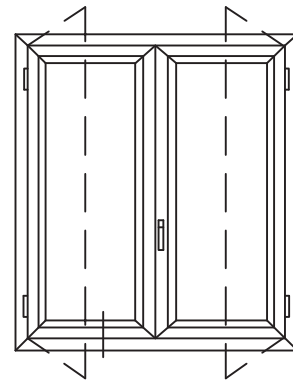

Open-in – casement glass door – threshold node

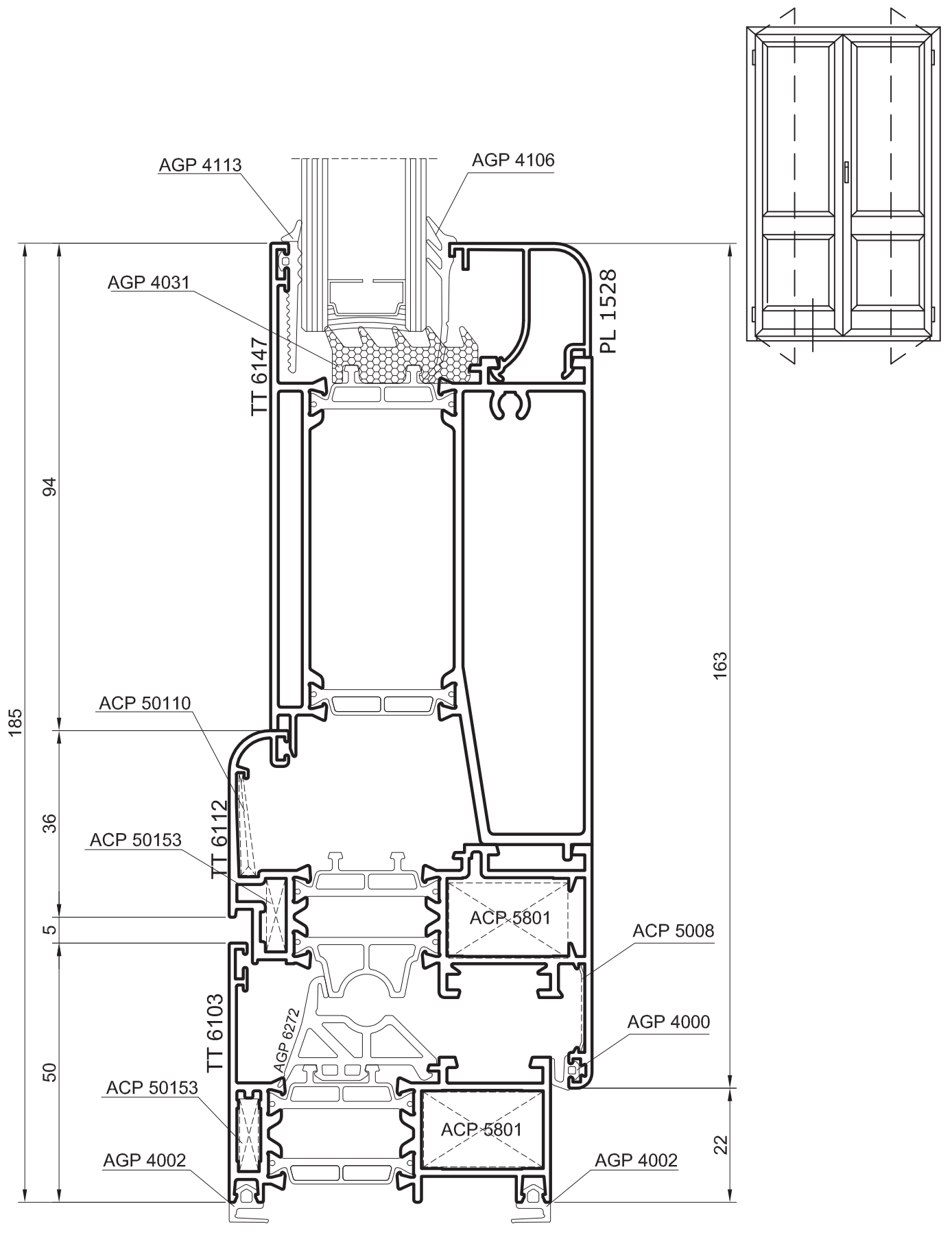

Open-in – casement window – sill node

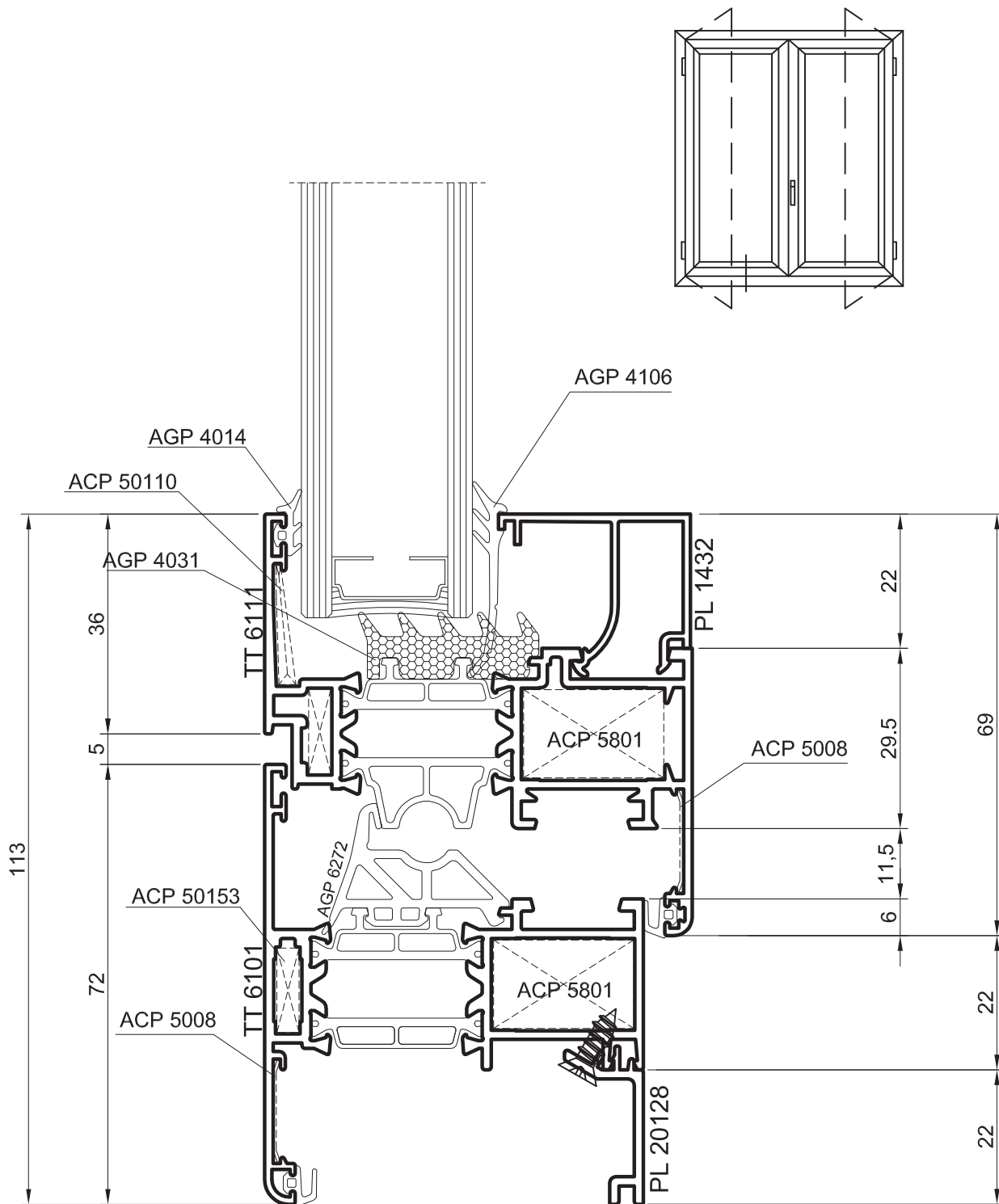

Open-in –casement door – lower node

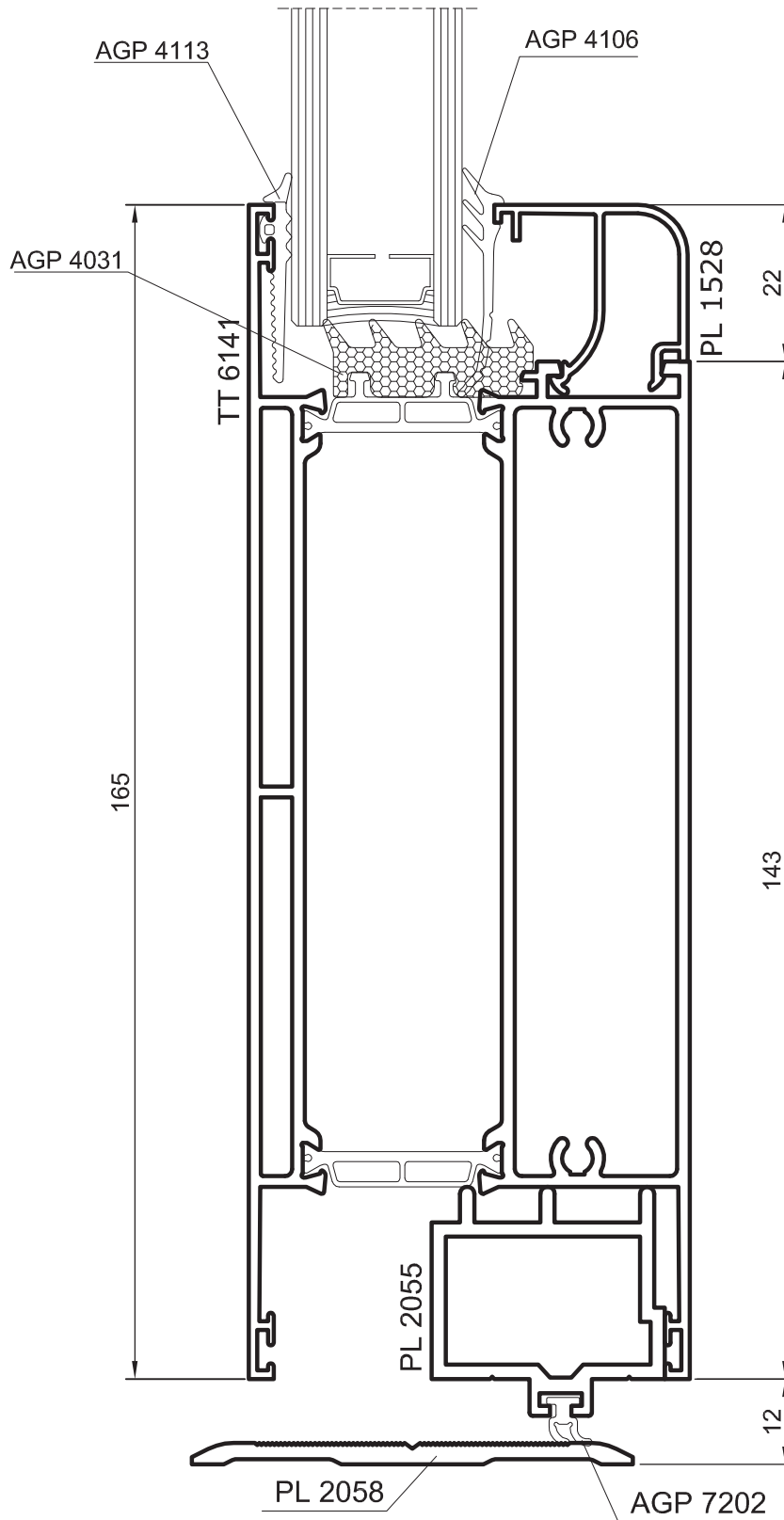
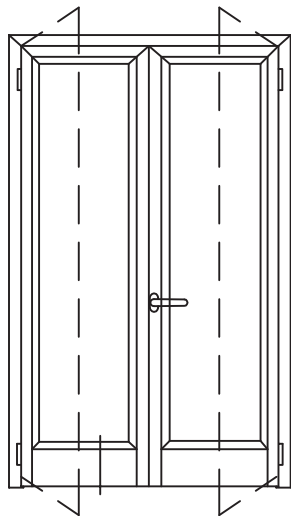

Combination node Slide range frame 106 mm

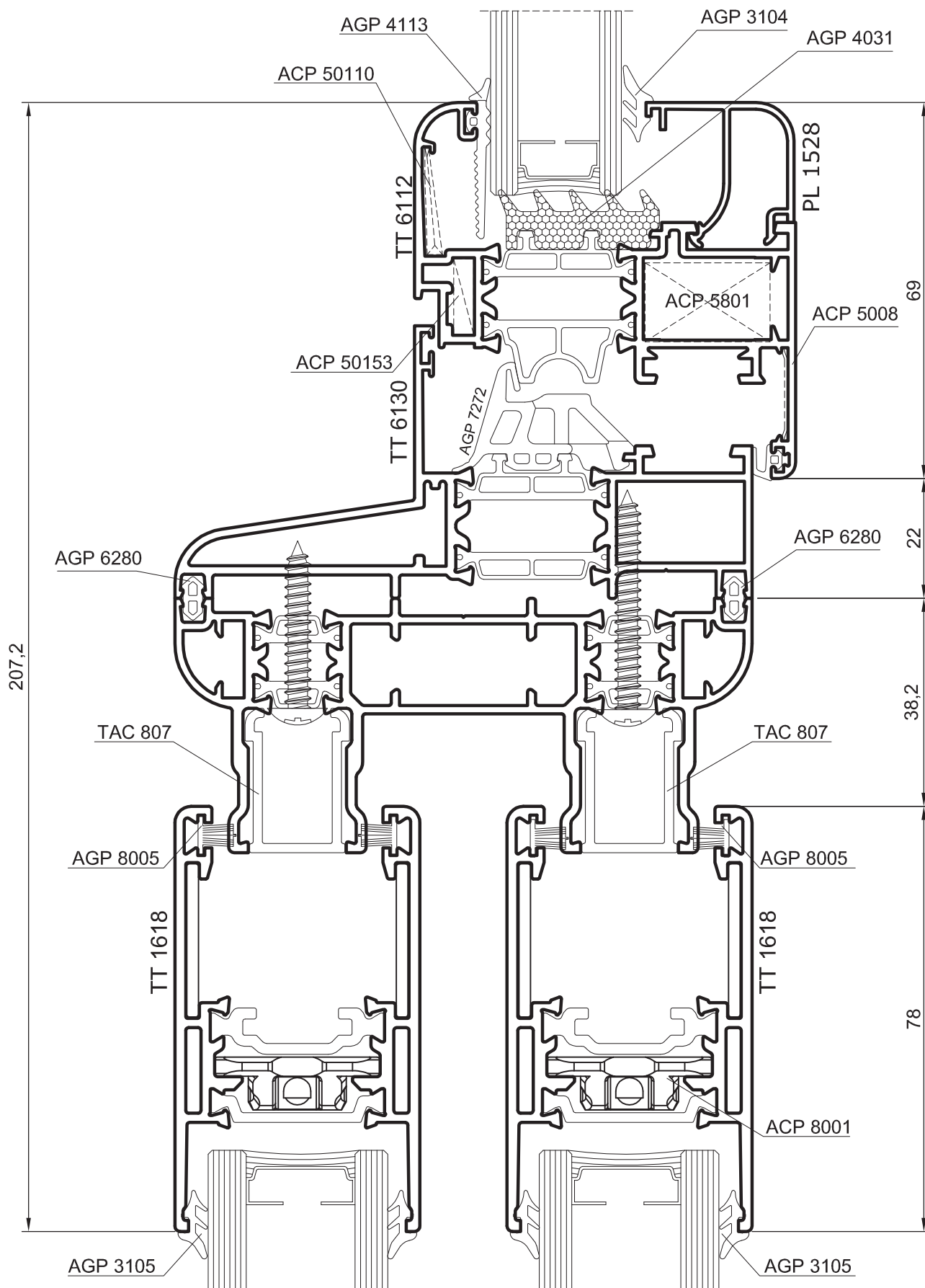

Combination node Slide range frame 80 mm

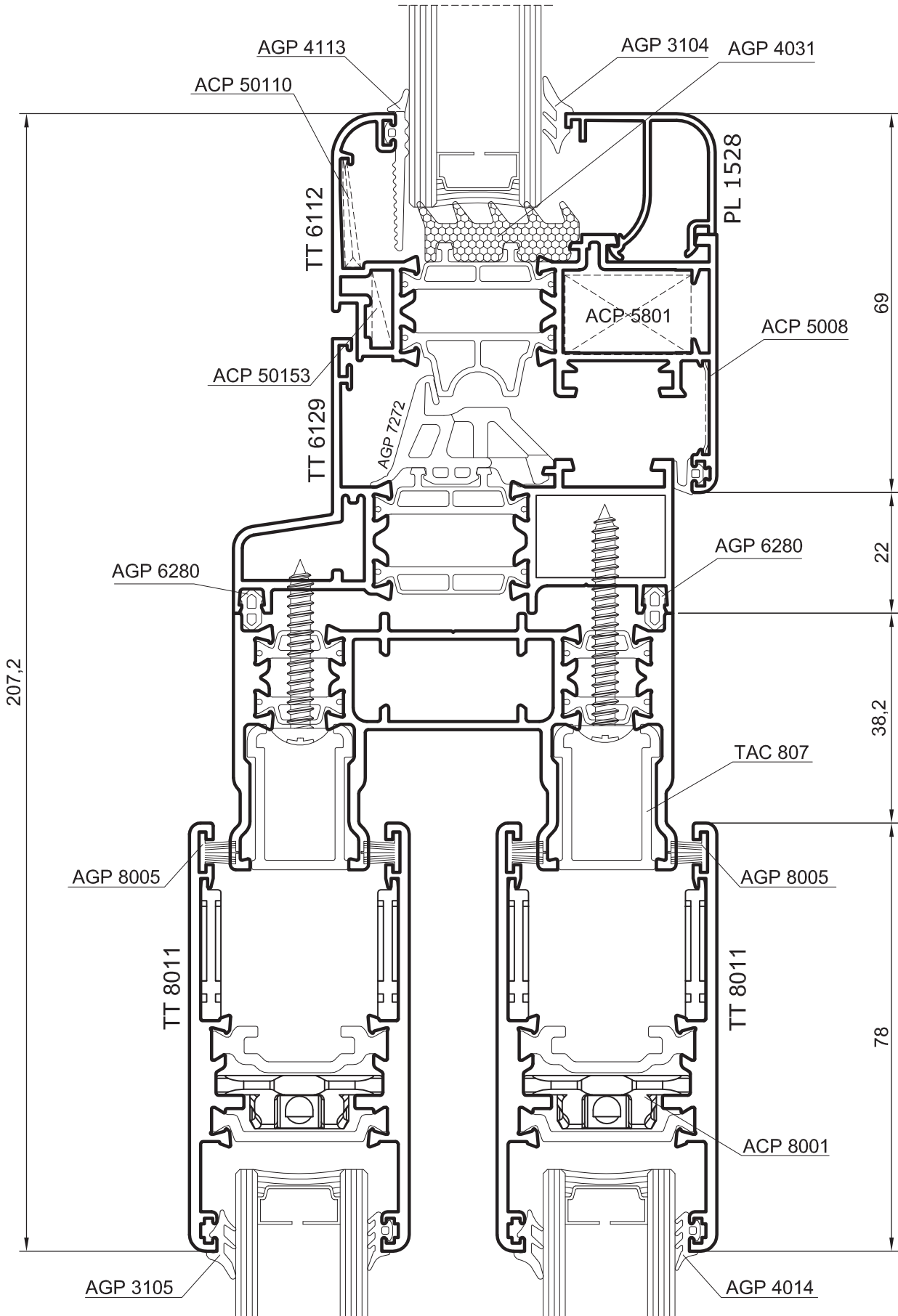

Open-in – casement window – central node

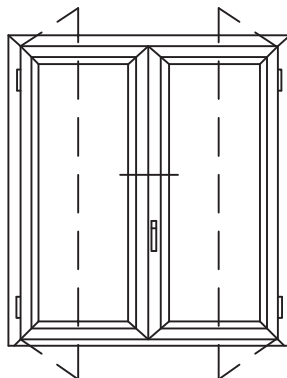
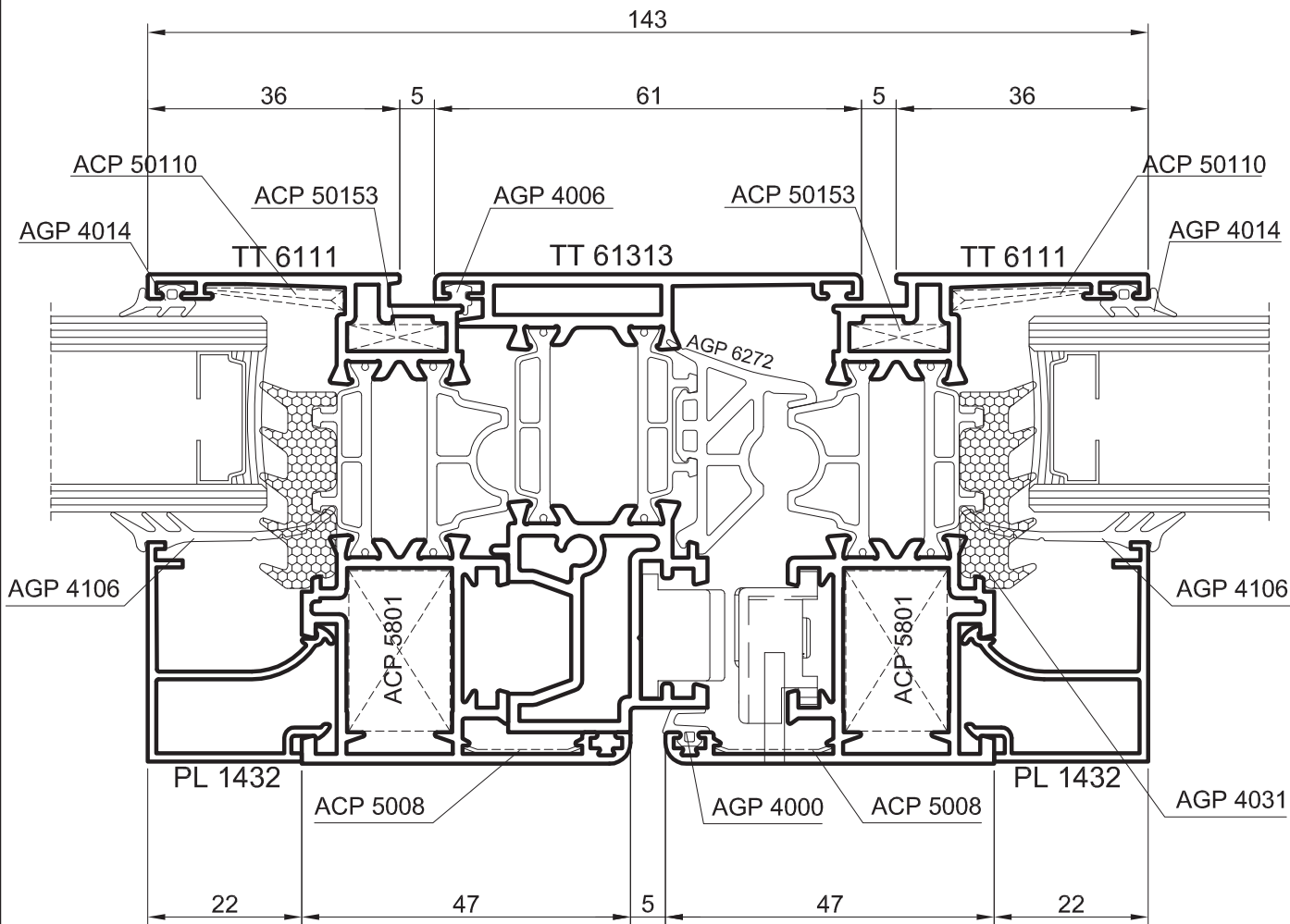

Open-in – casement window – central node

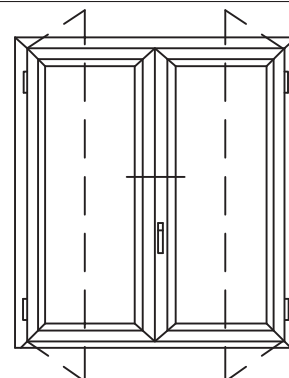
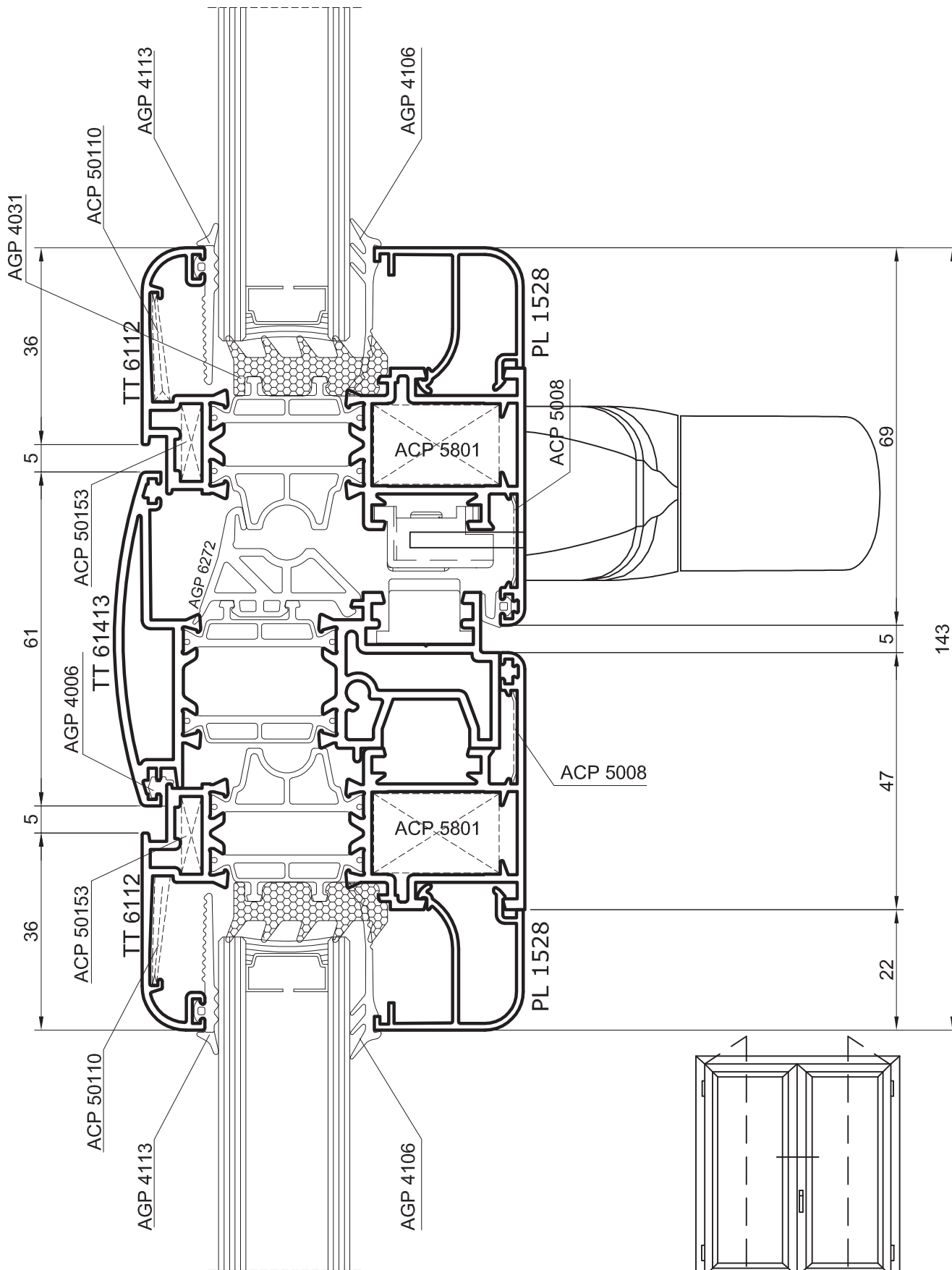

Open-out –casement door – central node

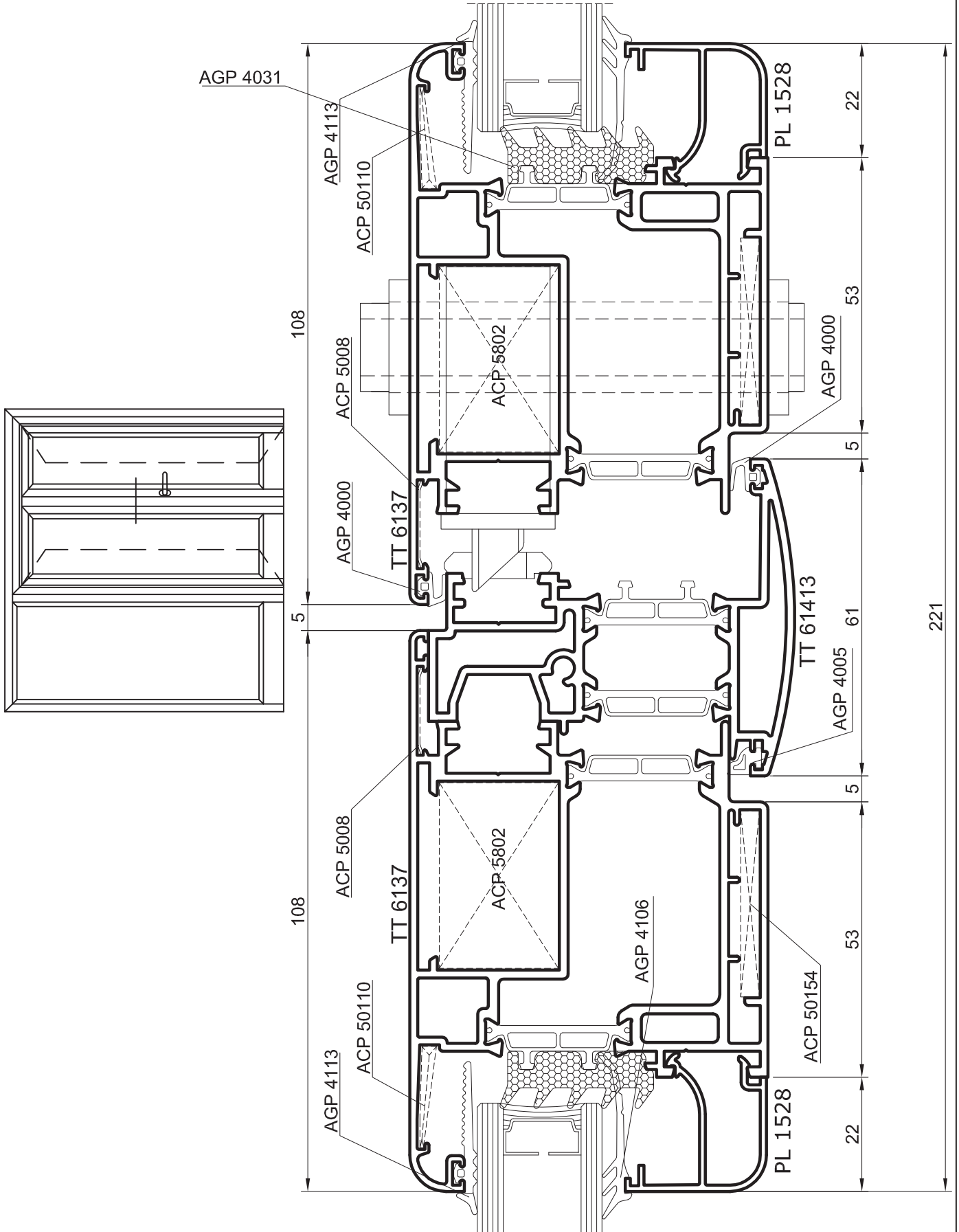

Open-in – casement glass door – central node

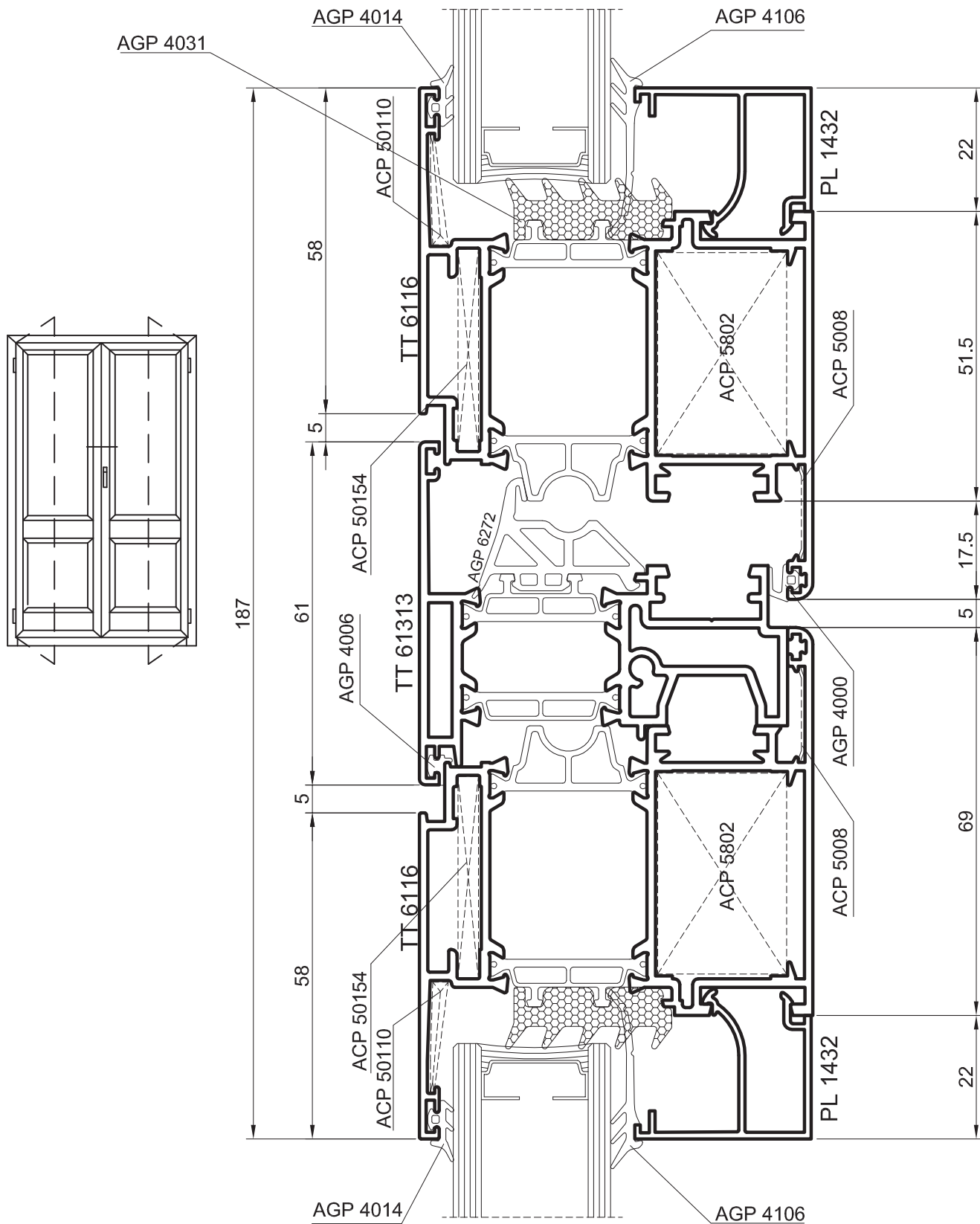

Pivot – lower perimeter node

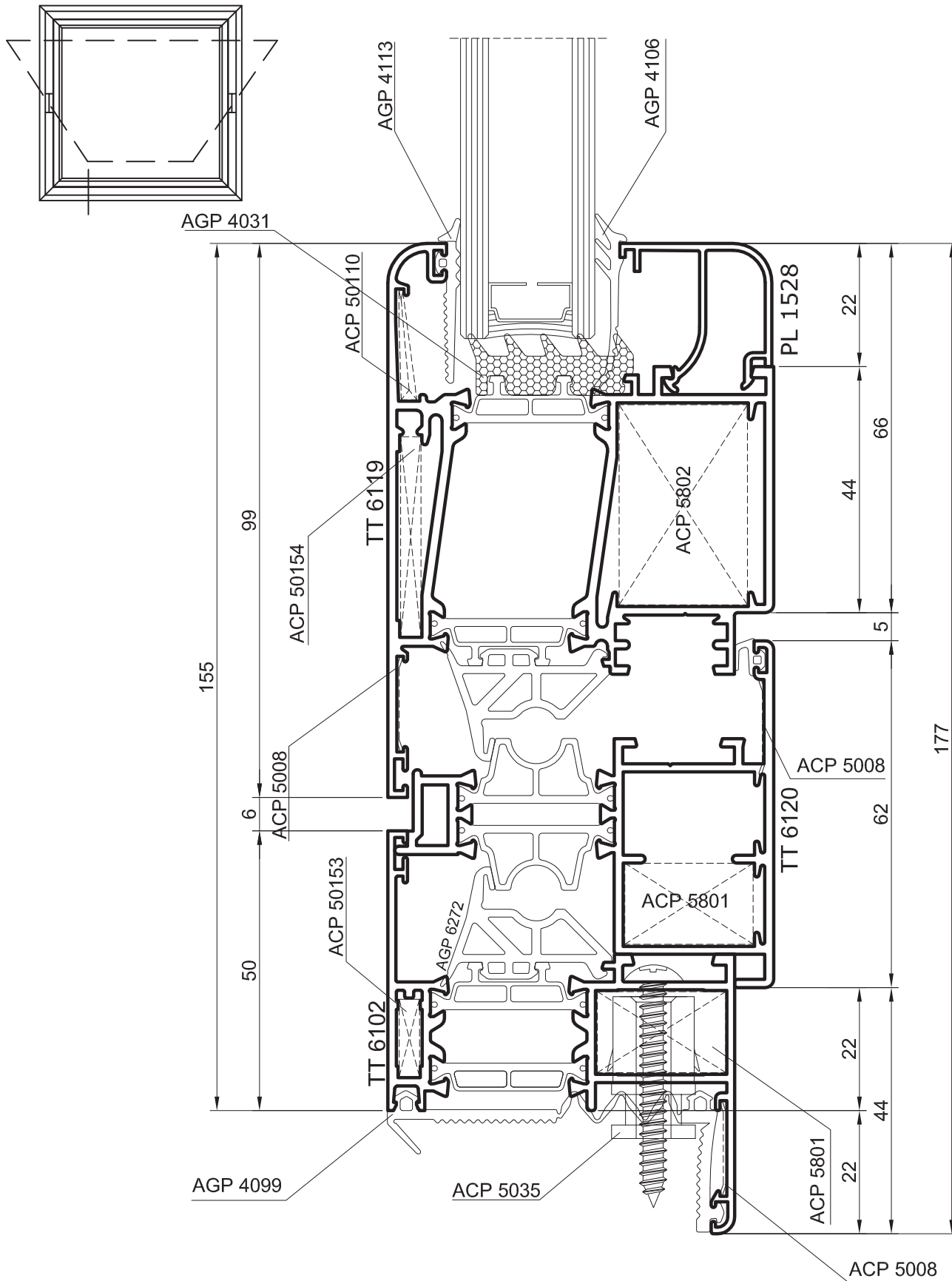

Industrial shed frame with wall profiles – perimeter node

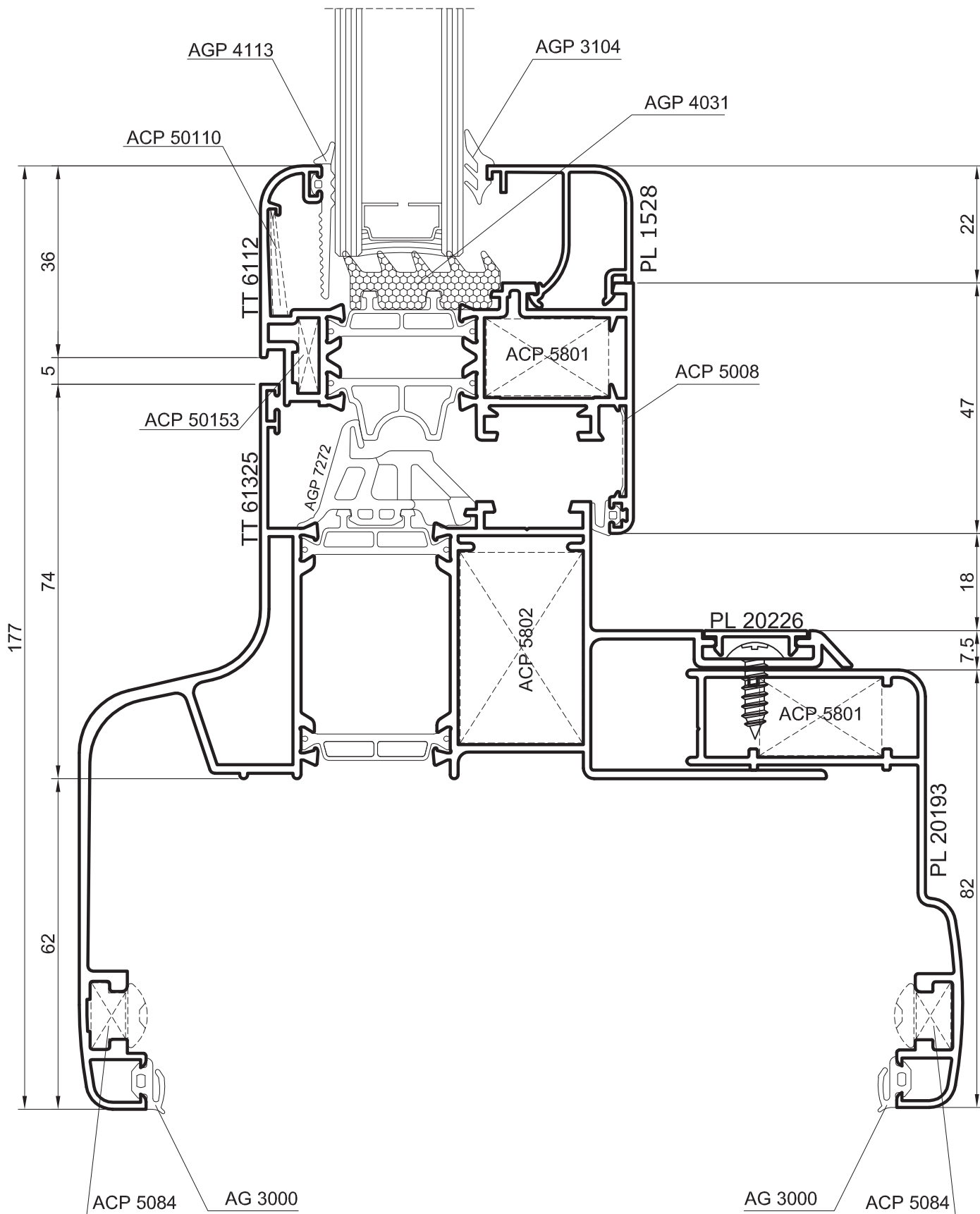

Industrial shed wall profiles – range of application

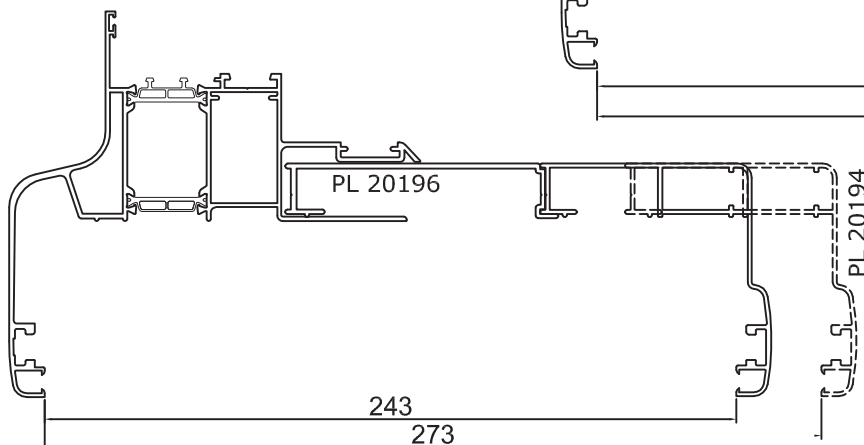
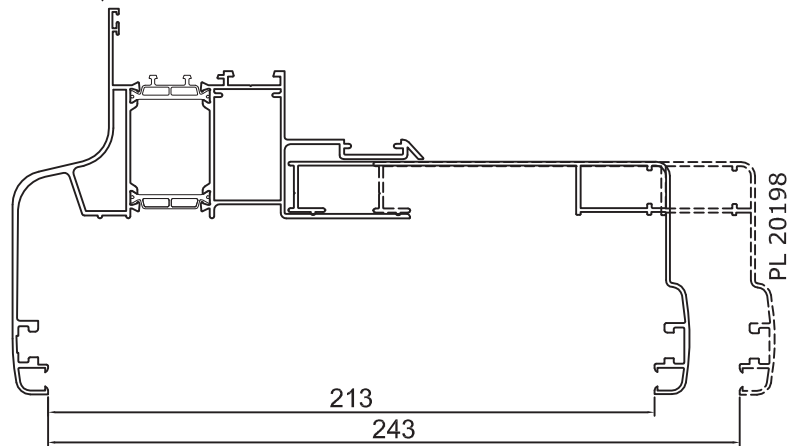
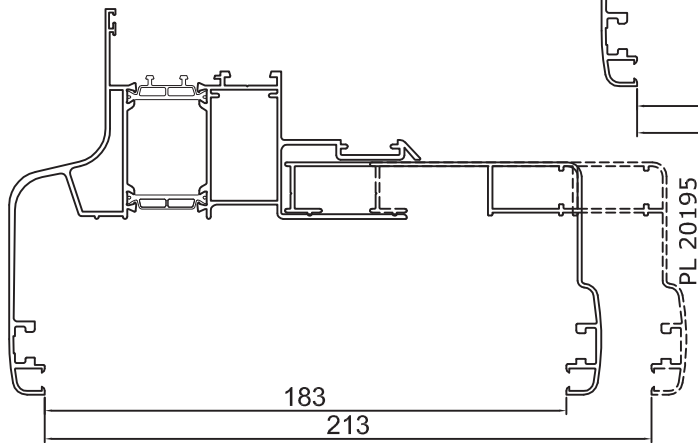
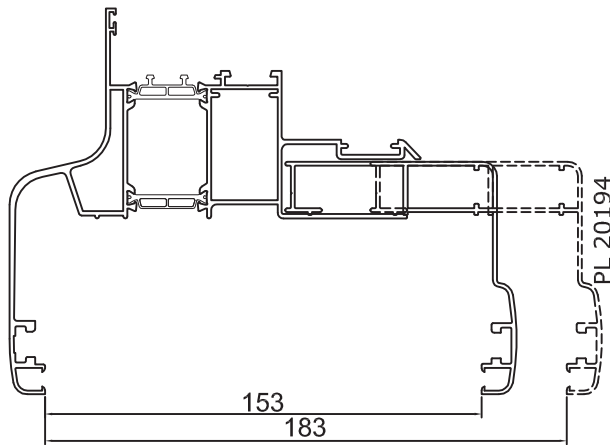
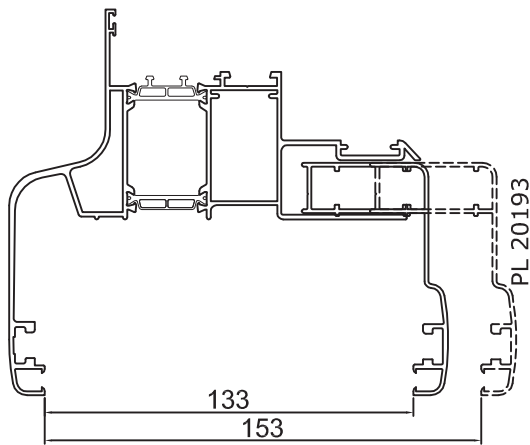

Industrial shed wall profiles – range of application

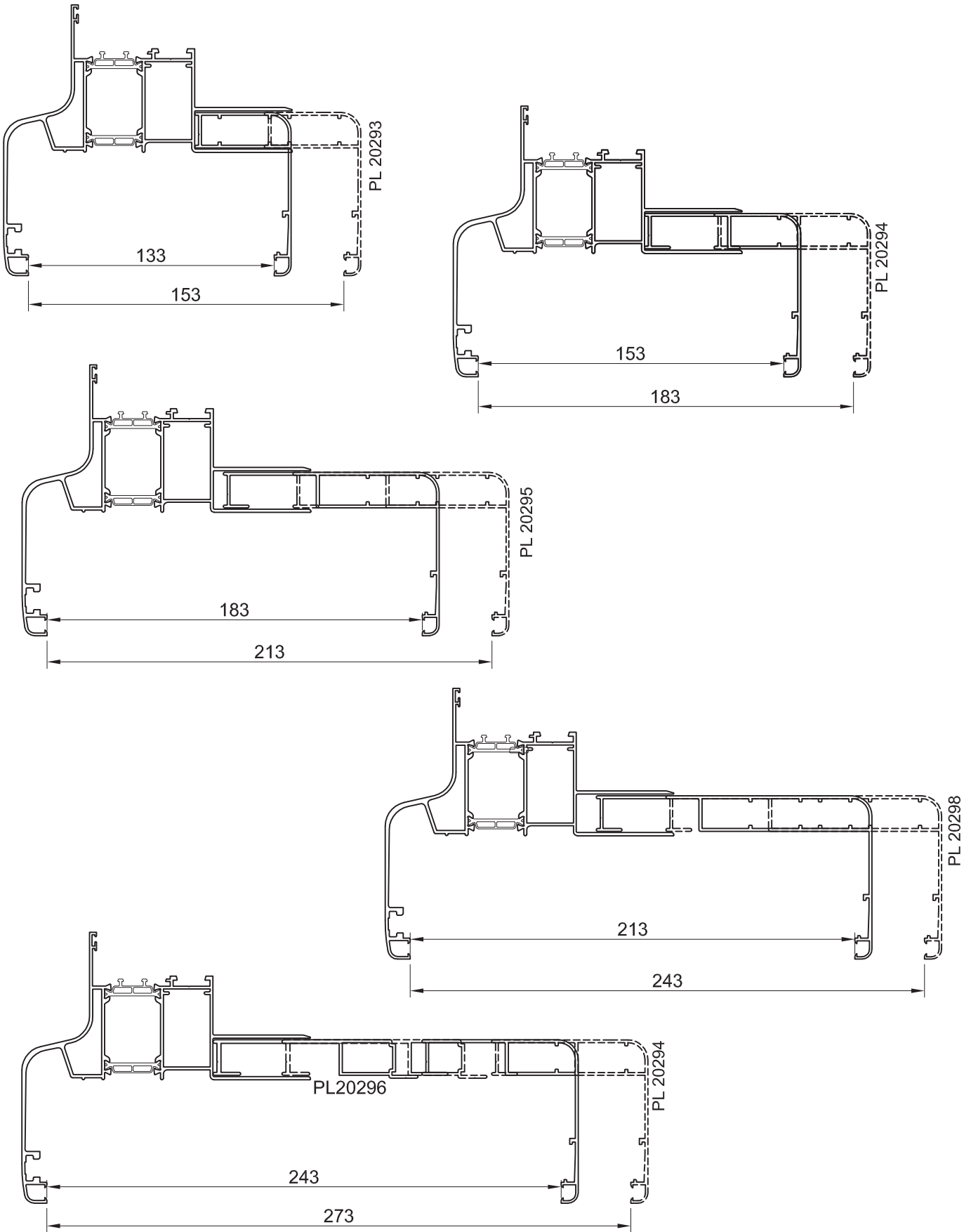

Ribbon windows – upper node

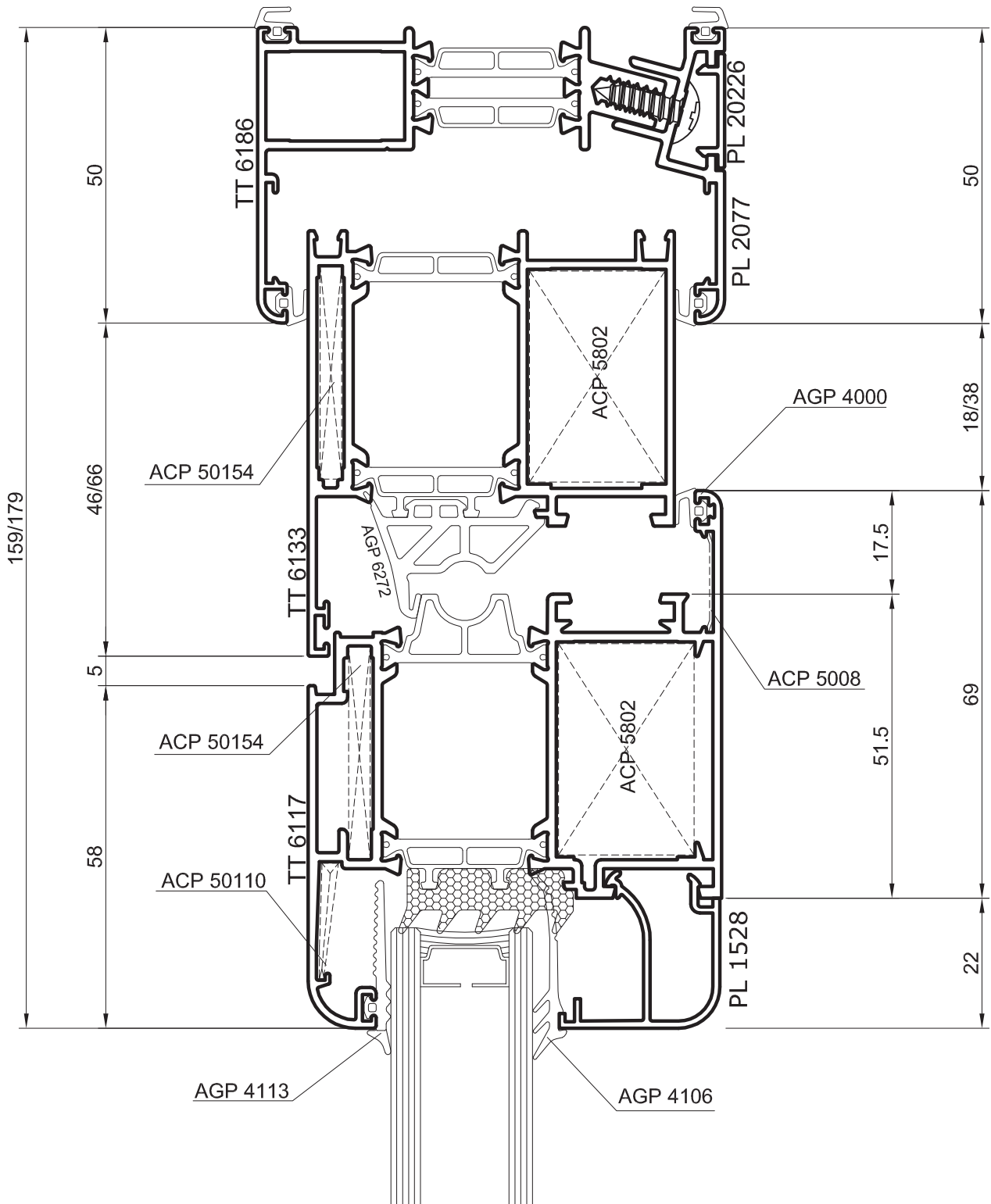

Ribbon windows – expansion joint

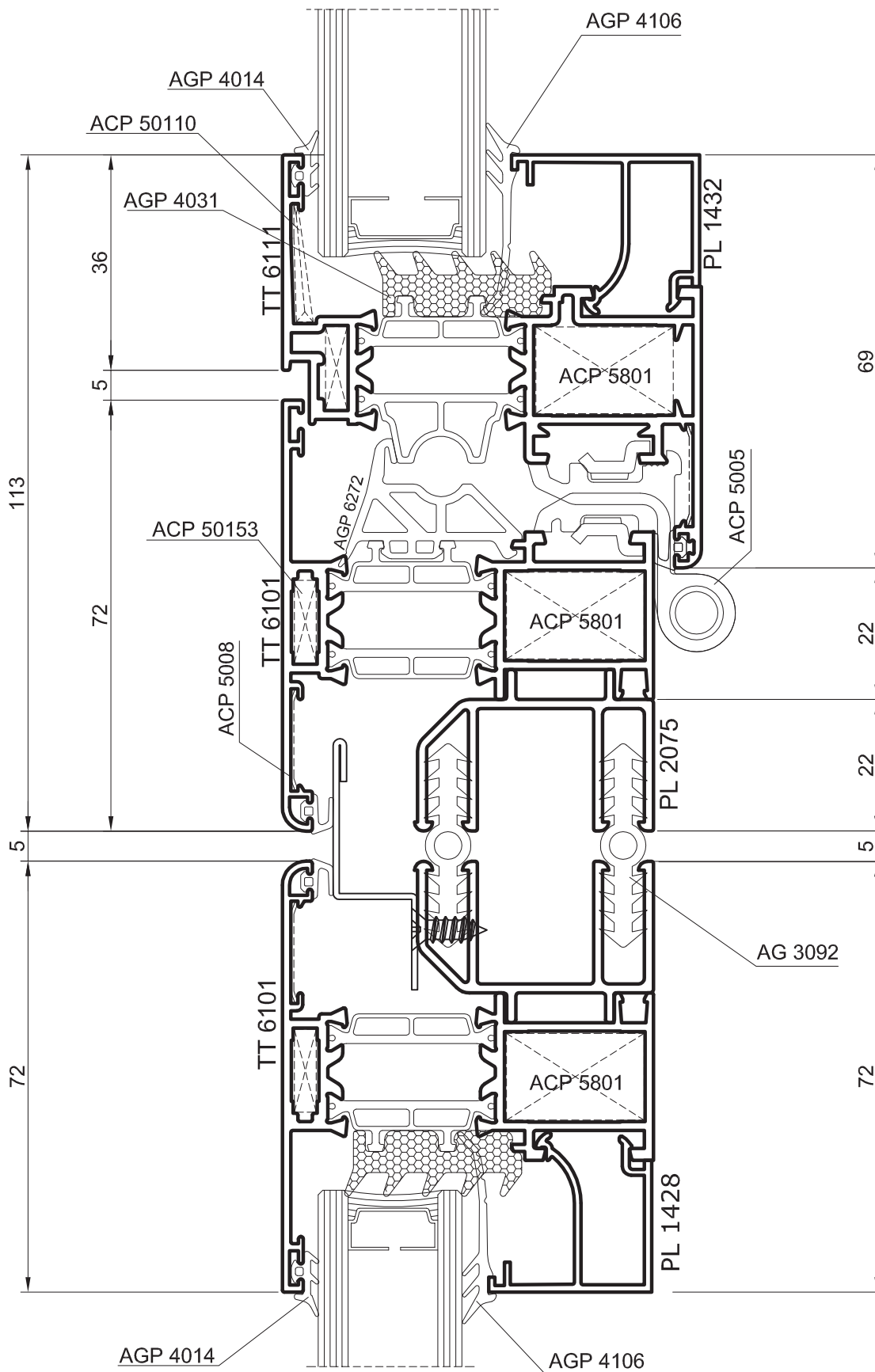

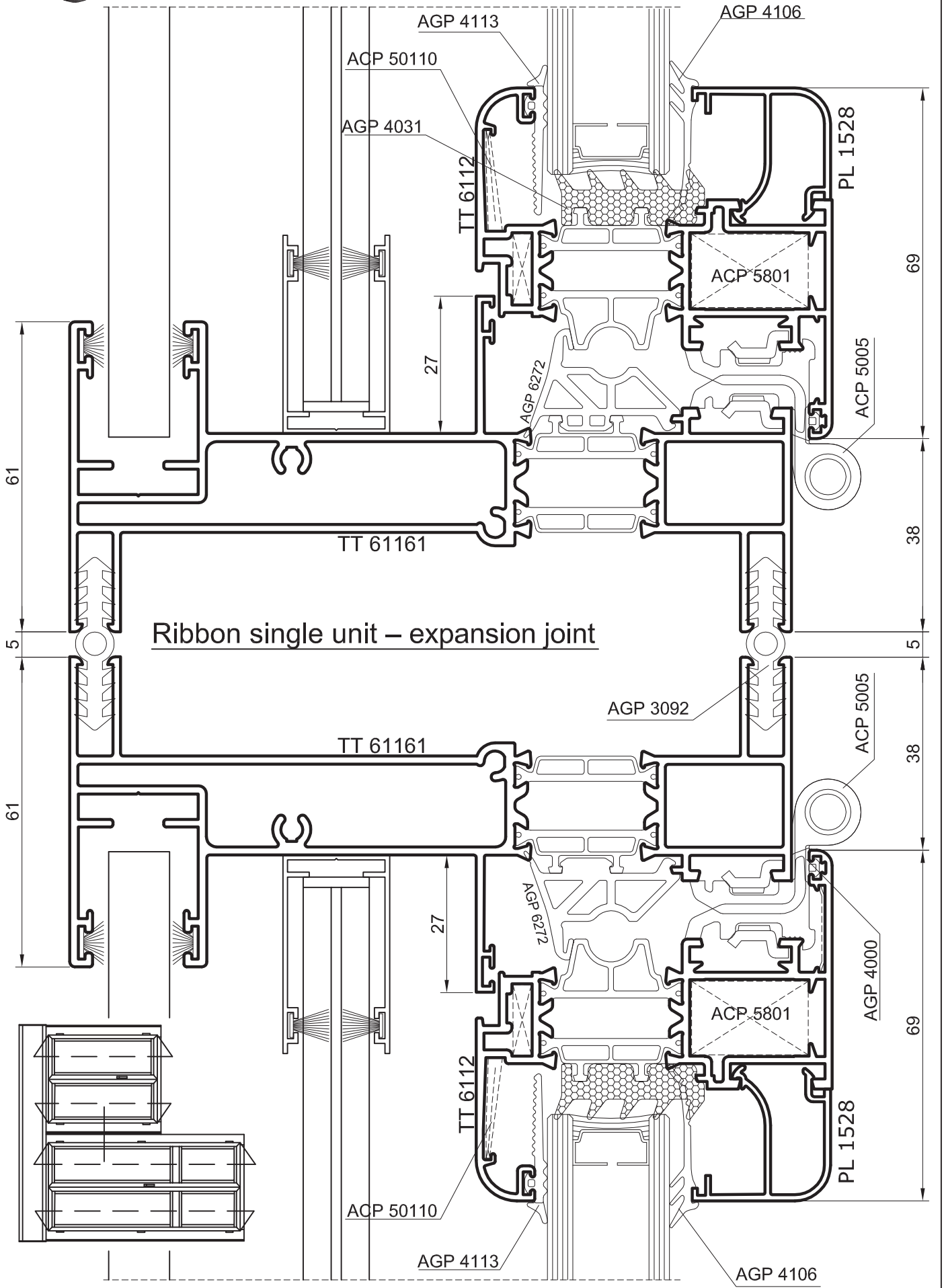

Tilt and turn single unit – lateral node

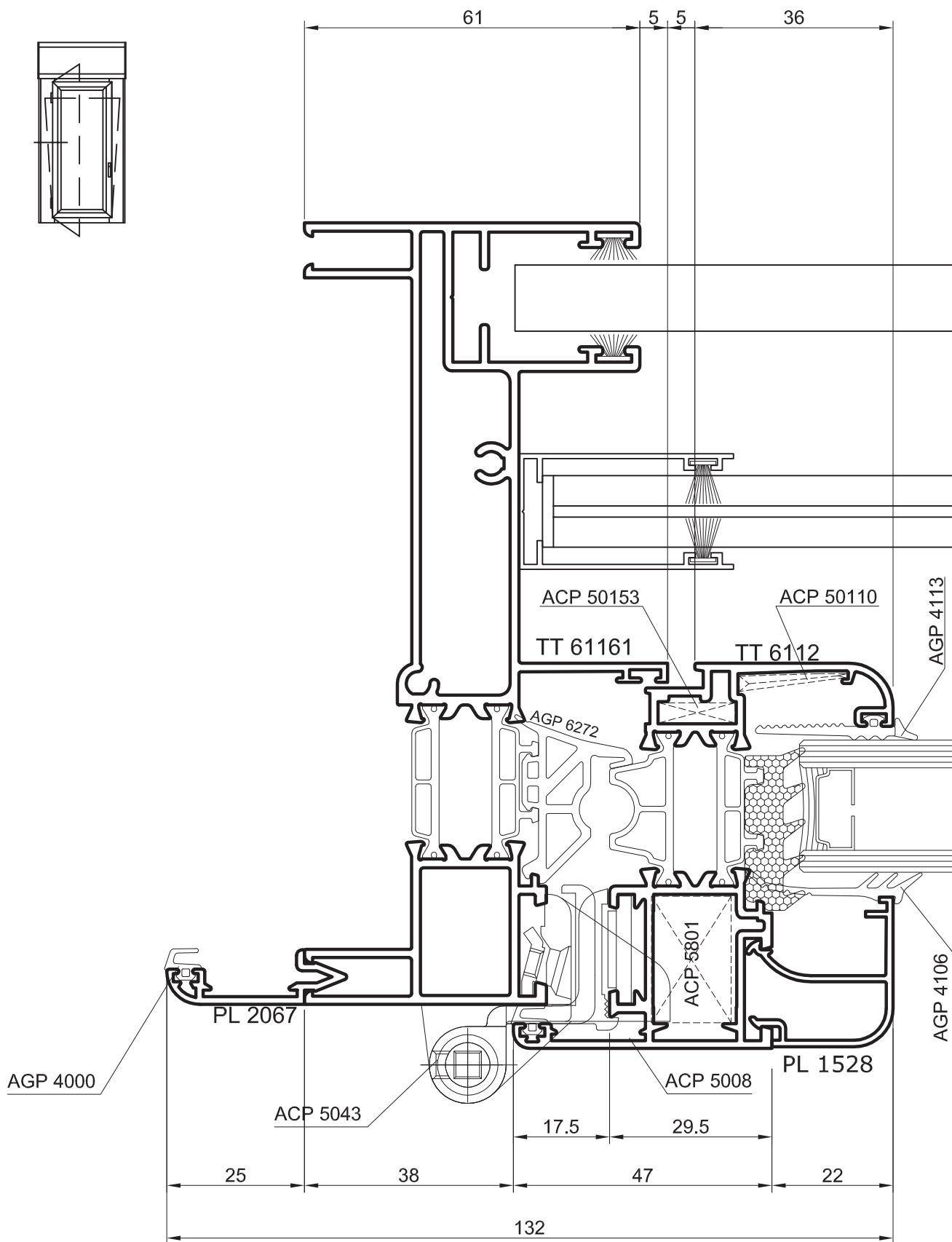

Tilt and turn single unit – lateral node

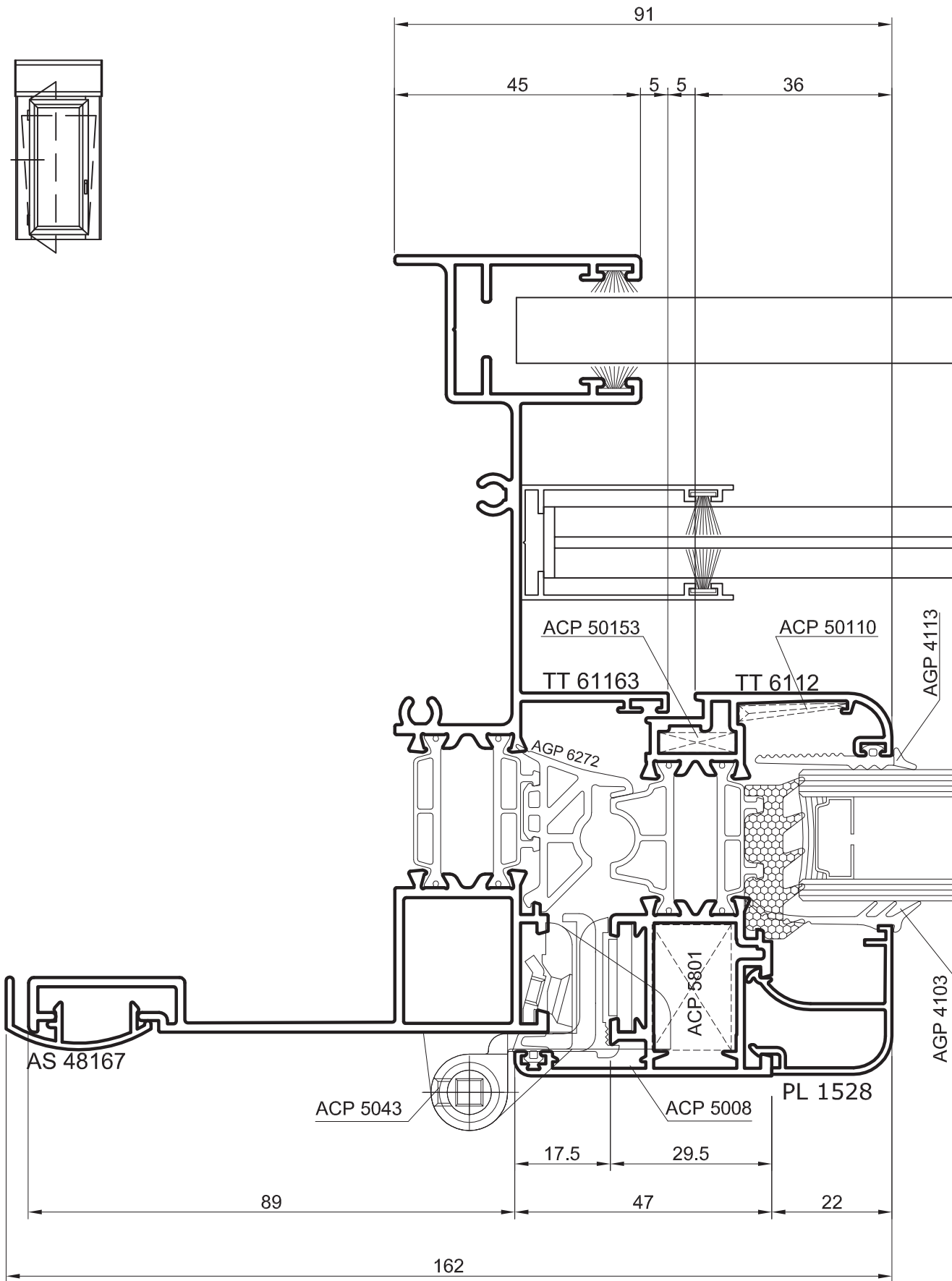

Single unit casement window – lateral node

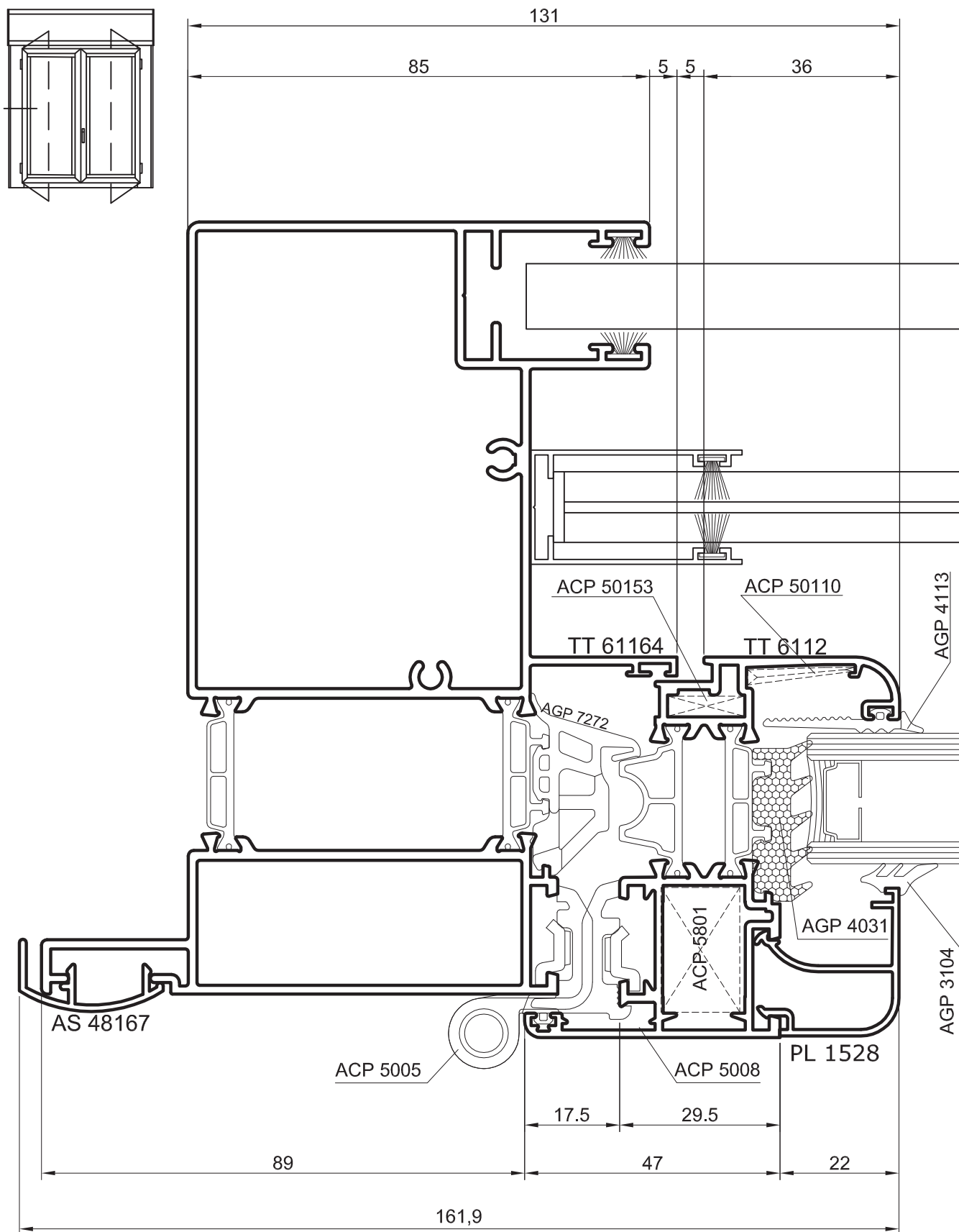

Single unit casement window – lateral node

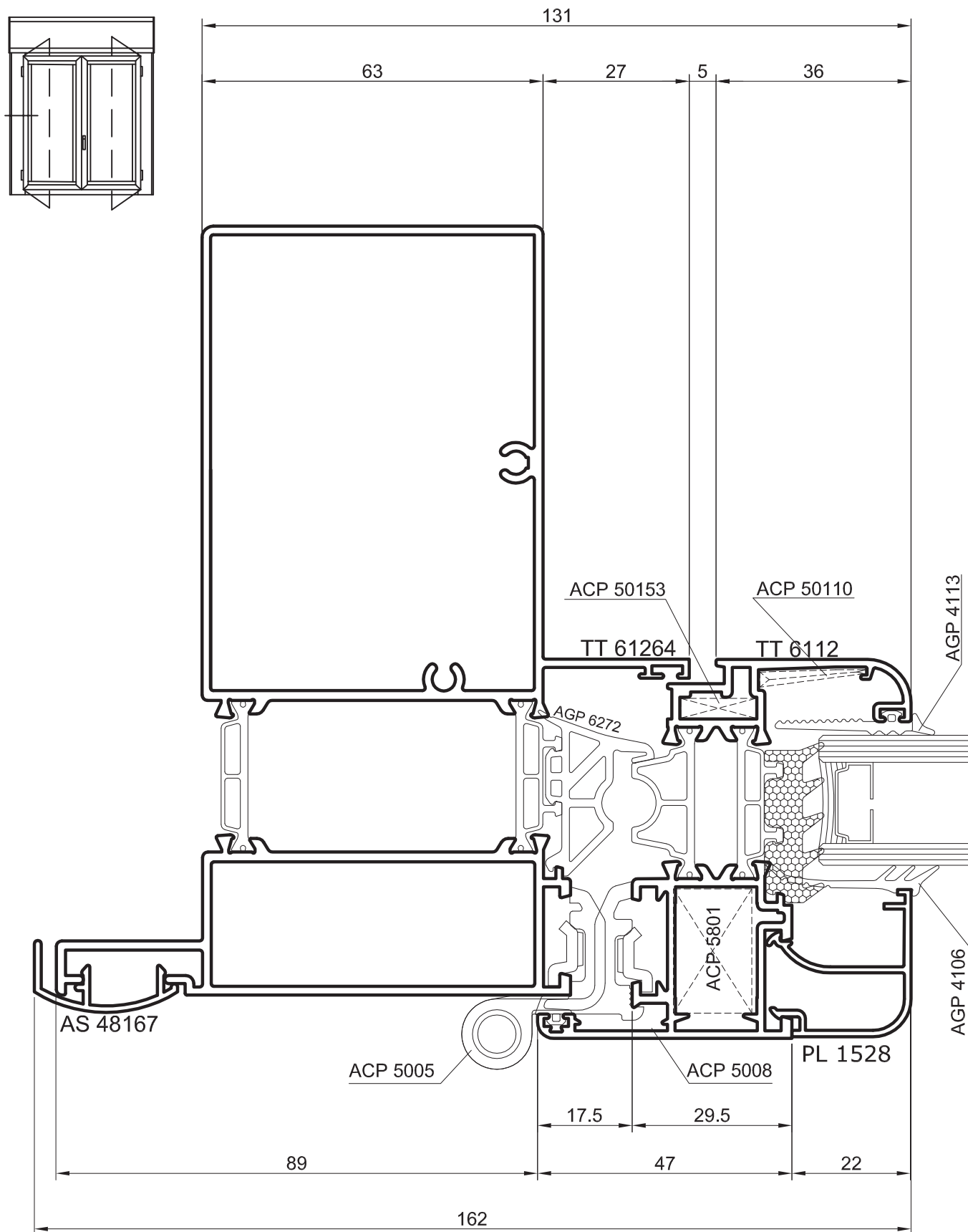

Ribbon window – half column

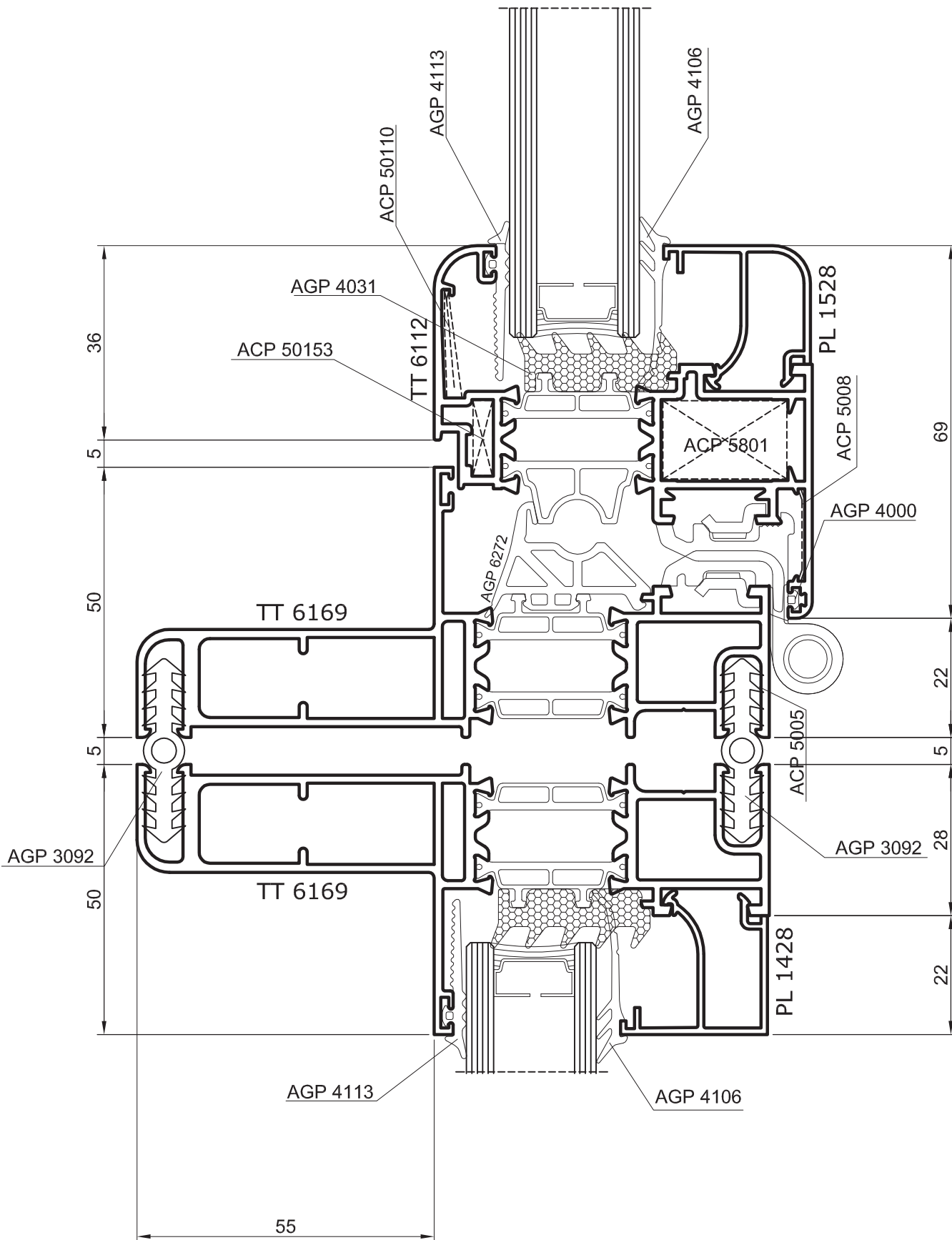

Single-unit casing

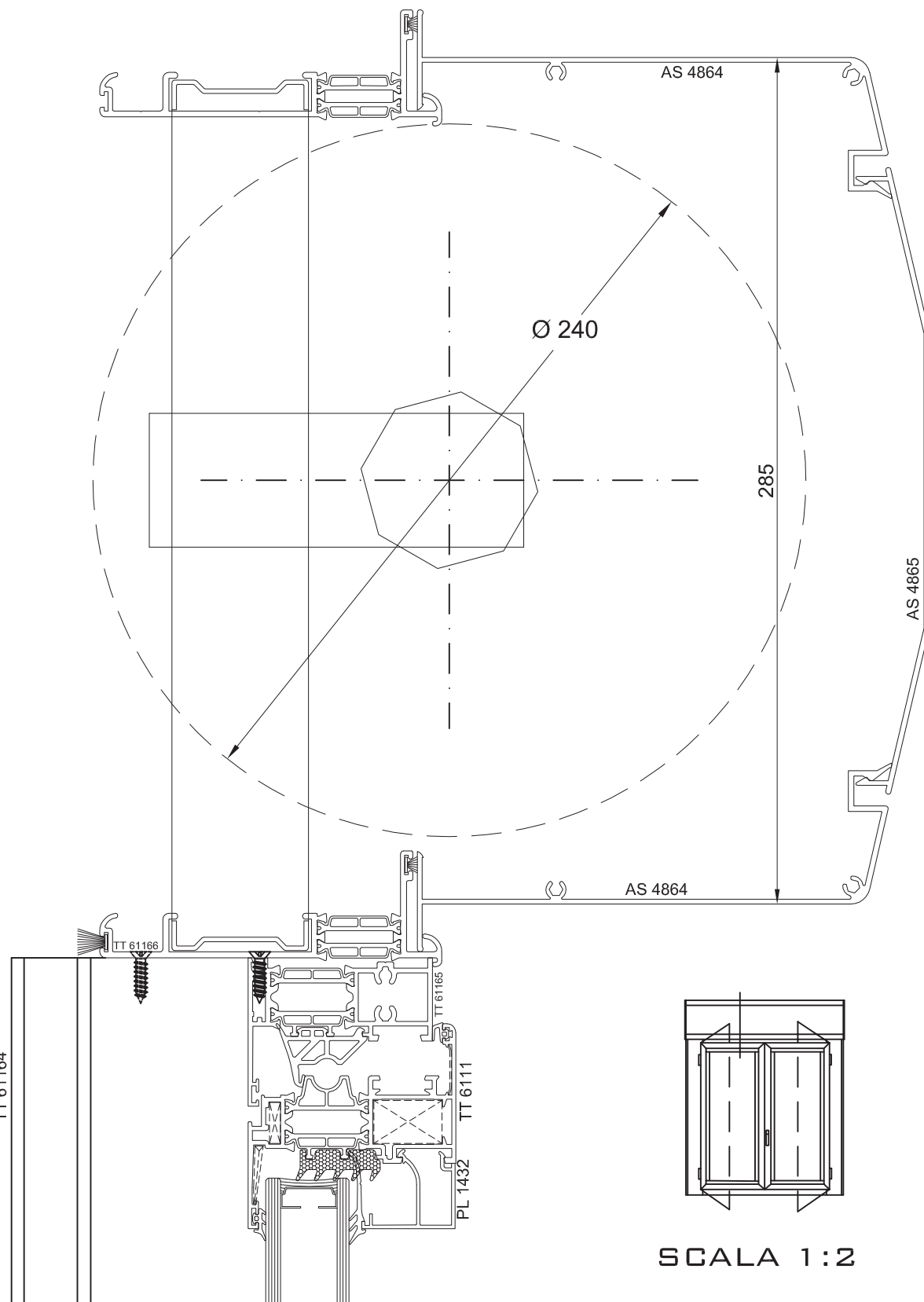

Parallel sliding – lower node

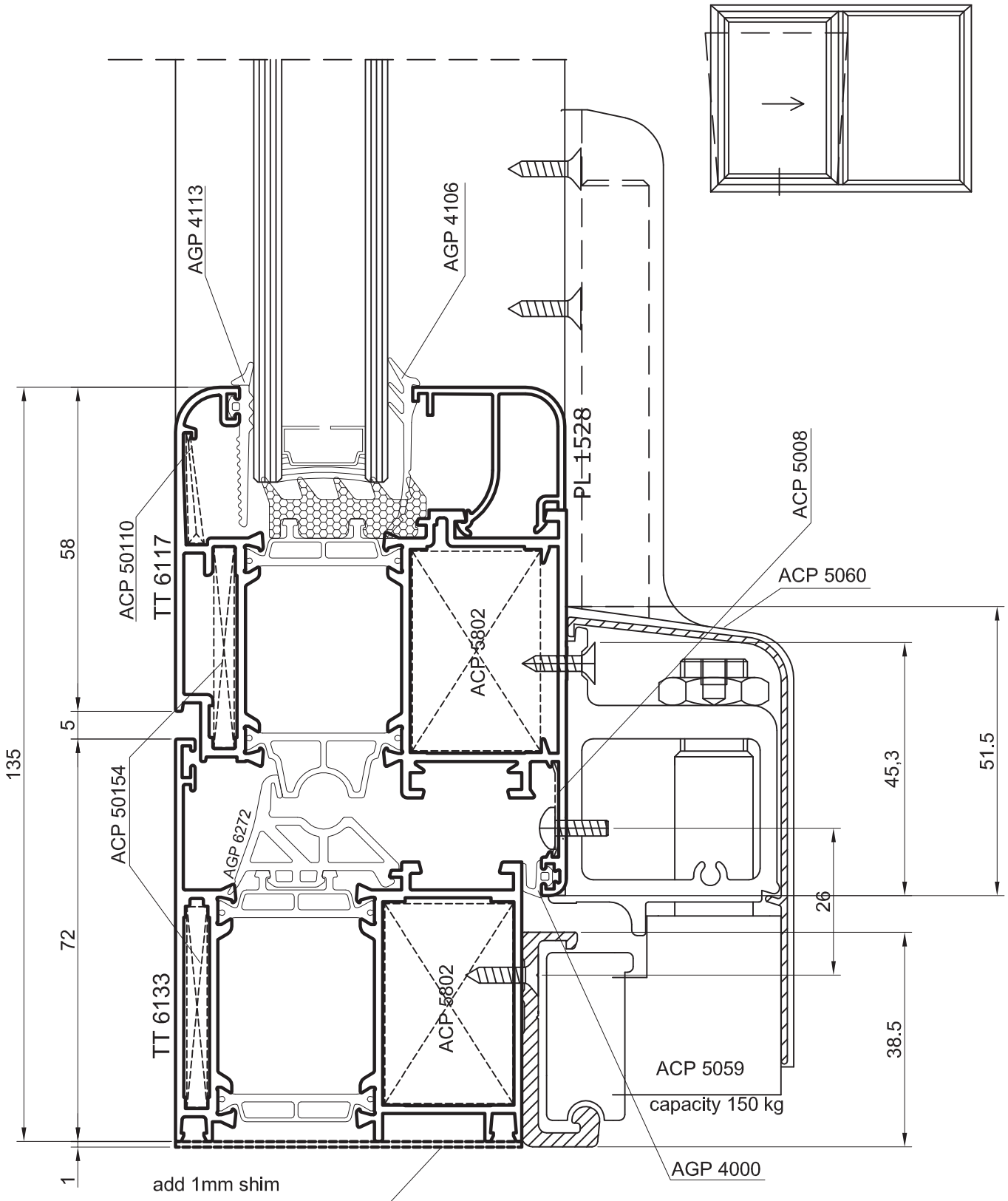

Ribbon windows – corner node

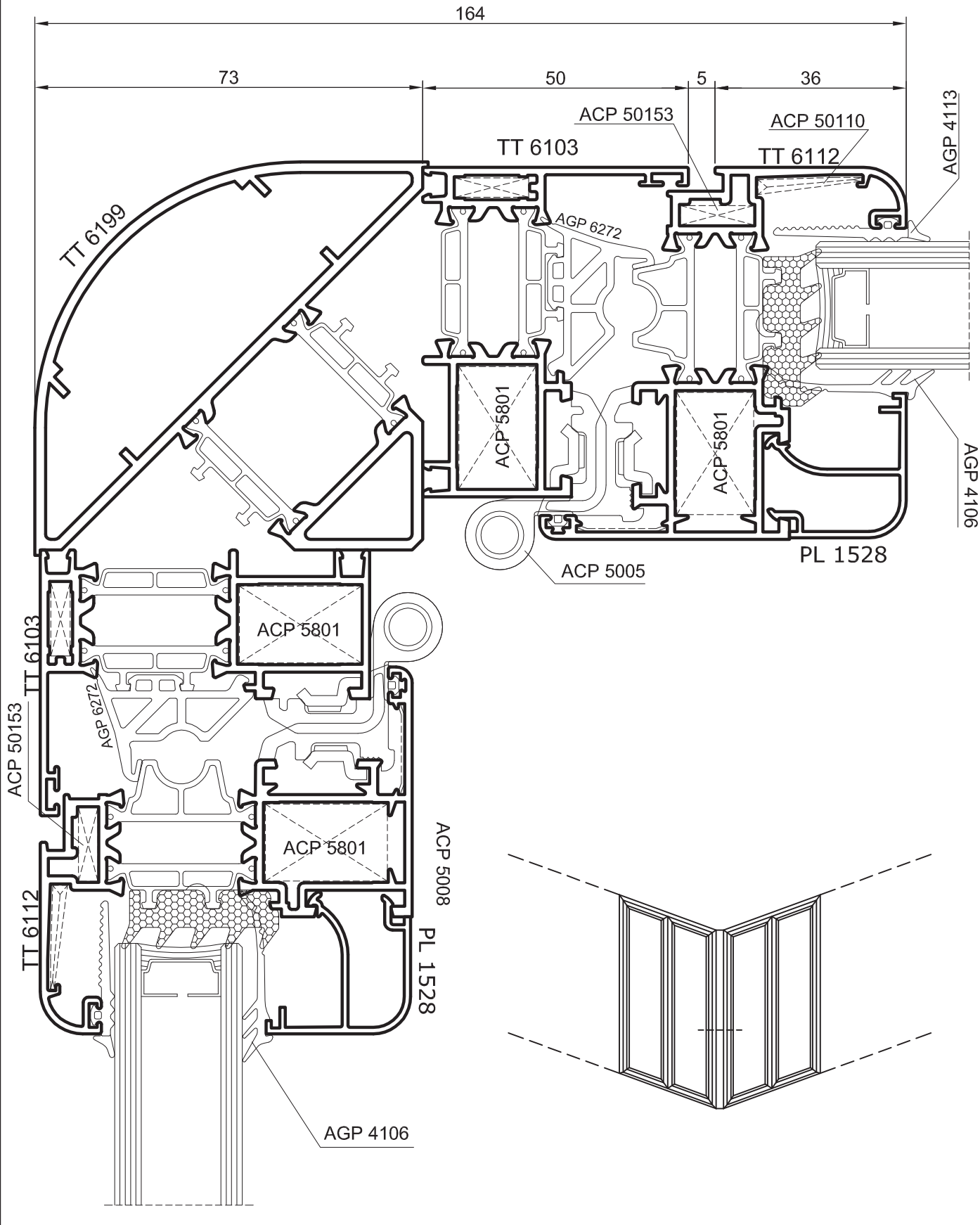

List of tools

	<p>MCT PL 319 06 01</p> <p>Partial punching machine for the Planet and Global range</p>		<p>MCT PL 402 02 28</p> <p>Complete kit for broaching-crimping profiles Planet 50TT and 62TT. Includes:</p> <ul style="list-style-type: none"> • 5 pairs of blades for Planet 50TT • 5 pairs of blades for Planet 62TT • 4 shim kits • Y iron <p>the kits can be used on broaching-crimping machines MAC210SC</p>
	<p>MCT PL 402 01 98</p> <p>Pneumatic machine for machining brackets with push-button 10.5mm</p>		<p>MCT PL 400 03 63</p> <p>Counterprofile for rounded glazing beads when a 45° cut is desired without using the angles the kit can be used on EM140G milling machines</p>
	<p>MCT PL 402 01 96</p> <p>Pneumatic machine for machining brackets to be pinned of the Planet range</p>		<p>MCT PL 319 06 35</p> <p>Portable punching machine for making the 3mm hole in the leaf for broaching the brackets ACP 50153 and ACP 50154</p>
	<p>MCT PL 319 06 05</p> <p>Punching machine for universal water drainage</p>		<p>MCT PL CIANFRINA</p> <p>Pair of blades for crimping the Planet range</p>
	<p>MCT PL 06PT</p> <p>Cutting machine for the Planet 62 TT range, only beadless glazing version</p>		<p>MCT PL JOLLY</p> <p>This punching machine performs all the specific machining for the Planet range: 45, 50TT, 62TT, Matic, Elite Door and partials Nathura and Slide</p>
	<p>MCT PL 08PT</p> <p>Cutting machine for the Planet 50TT and 62TT range, excluding the beadless glazing version</p>		<p>MCT PL PL01</p> <p>Punching machine for making the 3 mm hole in the leaf for broaching ACP 50153 and ACP 50154</p>
	<p>MCT PL 350 31/45</p> <p>Cutter stack for rounded glazing beads when a 45° cut is desired without using the angles the kit can be used on EM140G milling machines</p>		

Planet MCT PL 3190601 punching machine

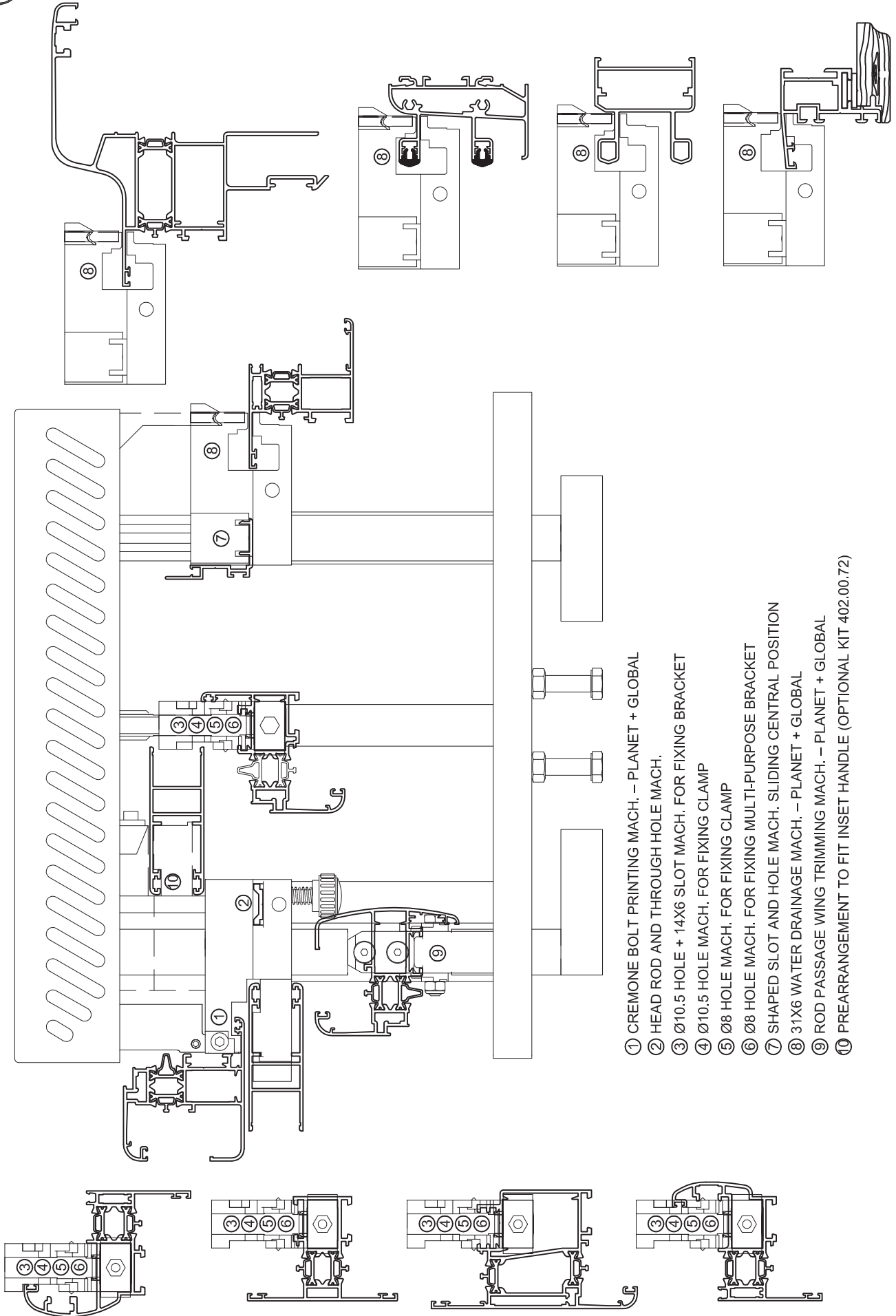

- ① CREMONE BOLT PRINTING MACH. – PLANET + GLOBAL
- ② HEAD ROD AND THROUGH HOLE MACH.
- ③ Ø10.5 HOLE + 14X6 SLOT MACH. FOR FIXING BRACKET
- ④ Ø10.5 HOLE MACH. FOR FIXING CLAMP
- ⑤ Ø8 HOLE MACH. FOR FIXING CLAMP
- ⑥ Ø8 HOLE MACH. FOR FIXING MULTI-PURPOSE BRACKET
- ⑦ SHAPED SLOT AND HOLE MACH. SLIDING CENTRAL POSITION
- ⑧ 31X6 WATER DRAINAGE MACH. – PLANET + GLOBAL
- ⑨ ROD PASSAGE WING TRIMMING MACH. – PLANET + GLOBAL
- ⑩ PREARRANGEMENT TO FIT INSET HANDLE (OPTIONAL KIT 402.00.72)

Planet MCT PL JOLLY punching machine

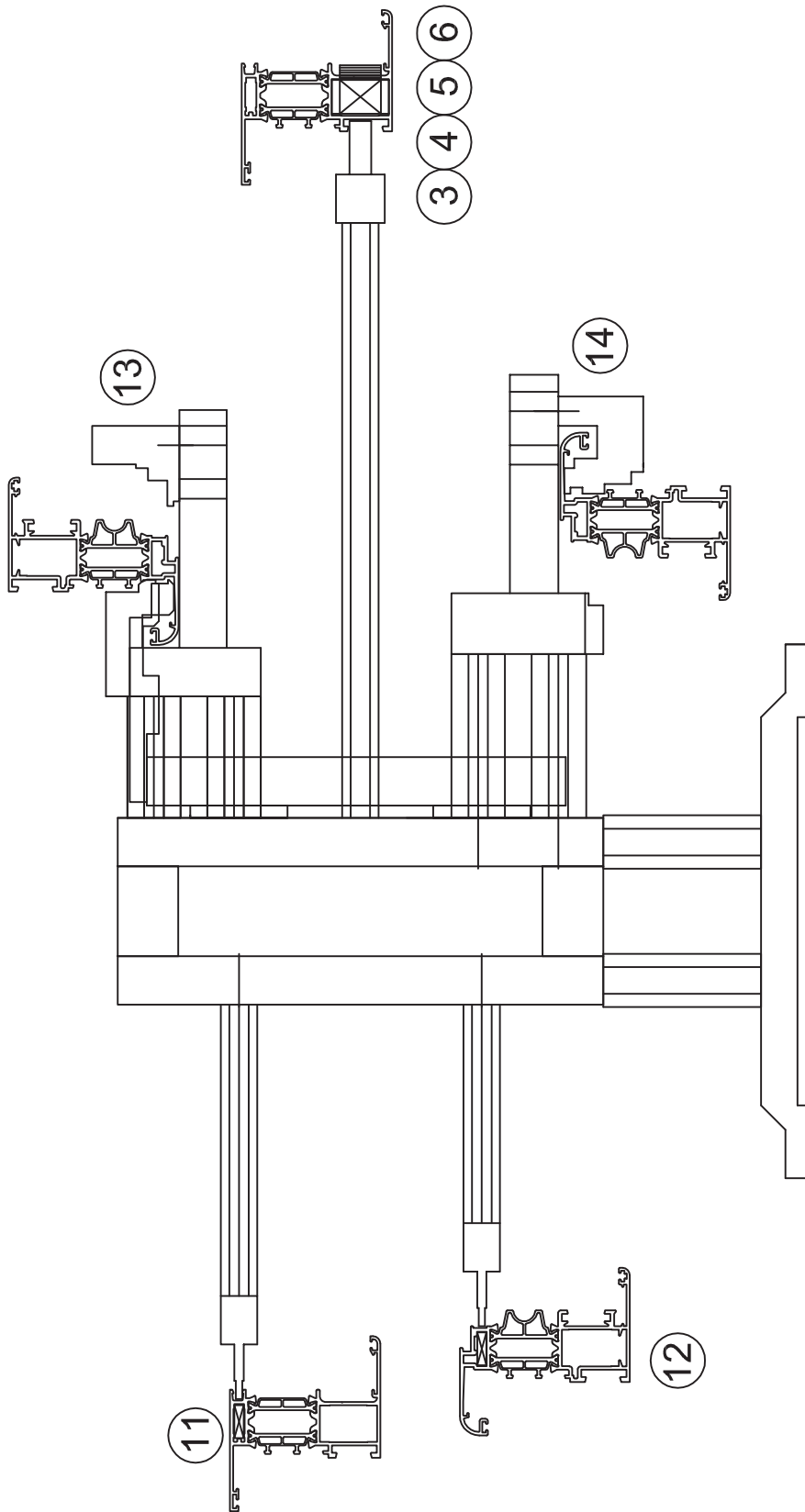

- ③ Ø10.5 HOLE + 14x6 SLOT MACHINING FOR FIXING BRACKET
- ④ Ø10.5 HOLE MACHINING FOR FIXING CLAMP
- ⑤ Ø8 HOLE MACH. FOR FIXING CLAMP
- ⑥ Ø8 HOLE MACH. FOR FIXING MULTI-PURPOSE BRACKET
- ⑦ Ø 3 mm HOLE FOR PIN ACP5030 BRACKET ACP 50153, ACP 50154
- ⑧ Ø 4 mm HOLE FOR SCREW ACP 50155 BRACKET ACP 50153, 50154
- ⑨ INTERNAL SLOT FOR LEAF VENTILATION
- ⑩ EXTERNAL SLOT FOR LEAF VENTILATION

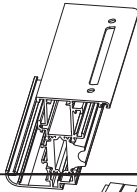
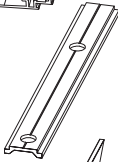
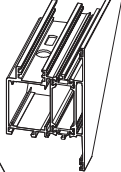
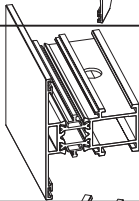
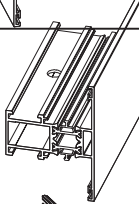
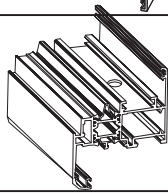
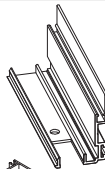
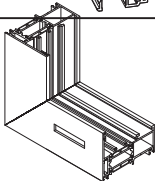
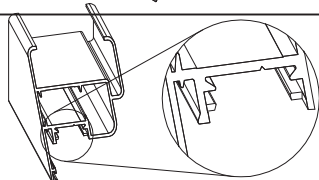
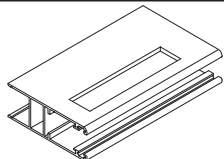
PRODUCT NUMBER	PRODUCT DESCRIPTION	MAGE OF PRODUCT	MACHINING WITH PUNCHING MACHINE MTC PL 3190601	MACHINING WITH PUNCHING MACHINE MCT PL JOLLY
1	SLOT AND HOLES LOCKING CREMONE BOLT CENTRE DISTANCE 104 mm OR 130 mm		yes	no
2	HOLE FOR HEAD ROD 8mm OR PASSING		yes	no
3	Ø10.5mm HOLE FOR FASTENING AND 14X6 SLOT FOR PUSH-BUTTON BRACKET KEY		yes	yes
4	Ø10.5mm HOLE FOR FIXING CLAMP		yes	yes
5	Ø 8 mm HOLE FOR FIXING CLAMP		yes	yes
6	Ø8mm HOLE FOR PIN OR SCREW MULTI-PURPOSE BRACKET		yes	yes
7	SLOT AND HOLE FOR PASSING GLOBAL SLIDING CONNECTION RAIL		yes	no
8	31X6 WATER DRAINAGE		yes	no
9	FIN TRIMMING ROD PASSAGE		yes	no
10	PREARRANGEMENT TO FIT GLOBAL SLIDING INSET HANDLE		yes	no

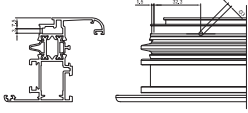
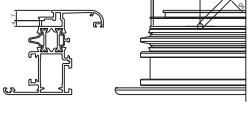
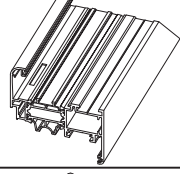
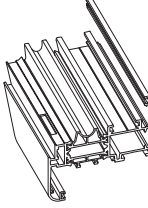
PRODUCT NUMBER	PRODUCT DESCRIPTION	IMAGE OF PRODUCT	MACHINING WITH PUNCHING MACHINE MTC PL 3190601	MACHINING WITH PUNCHING MACHINE MCT PL JOLLY
11	Ø 3 mm HOLE FOR PIN ACP5030 BRACKET ACP 50153, ACP 50154		no	yes
12	Ø 4 mm HOLE FOR SCREW ACP 50155 BRACKET ACP 50153, 50154		no	yes
13	INTERNAL SLOT FOR LEAF VENTILATION		no	yes
14	EXTERNAL SLOT FOR LEAF VENTILATION		no	yes

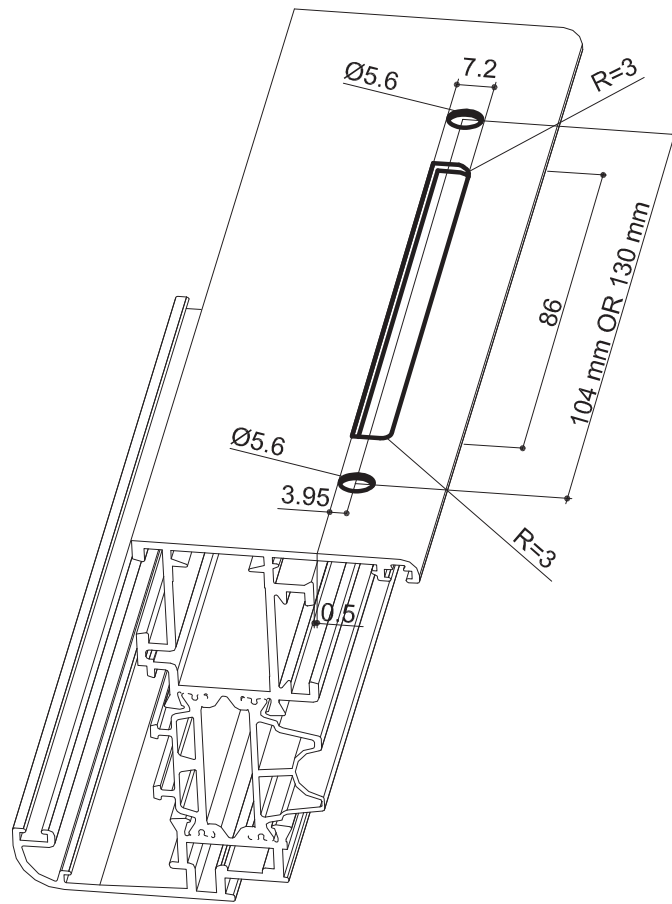

1

SLOT AND HOLES
LOCKING
CREMONE BOLT CENTRE
DISTANCE
104 mm OR 130 mm

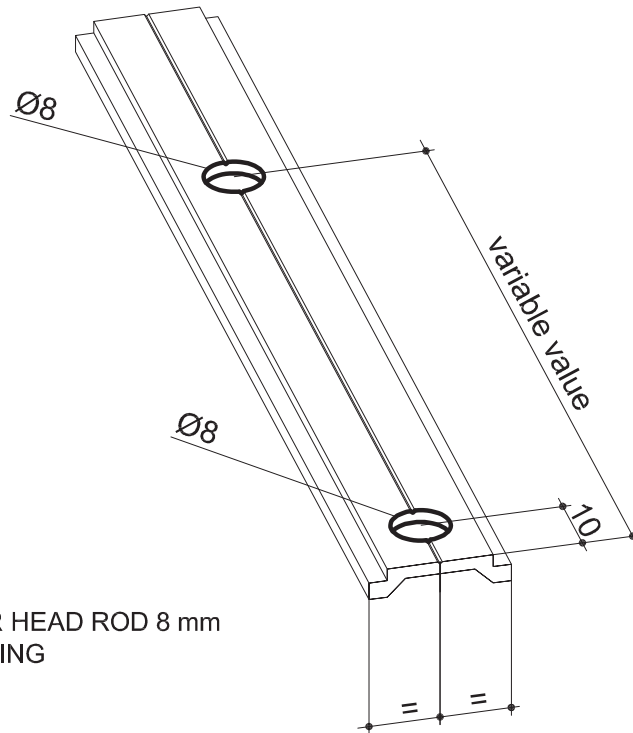

2

HOD FOR HEAD ROD 8 mm
OR PASSING

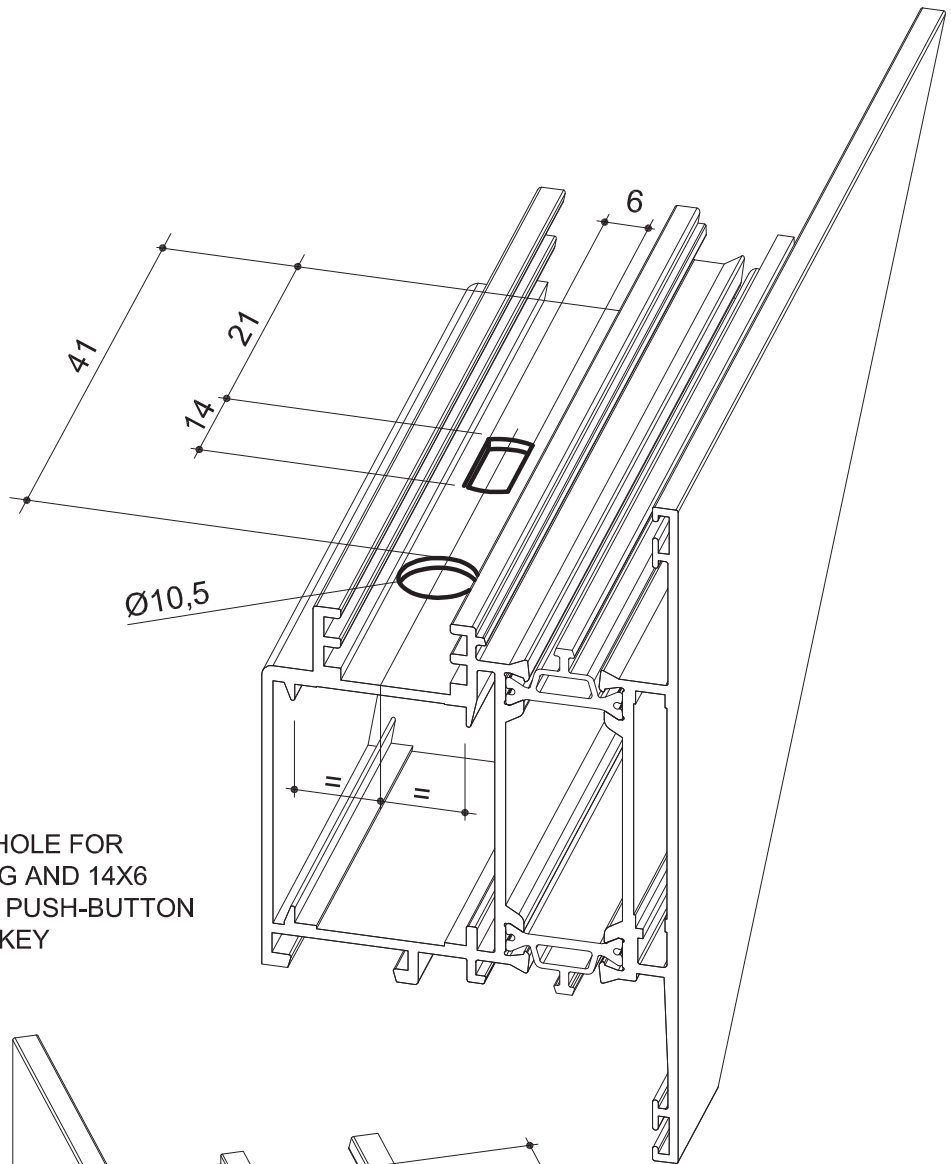

3

Ø10.5mm HOLE FOR FASTENING AND 14X6 SLOT FOR PUSH-BUTTON BRACKET KEY

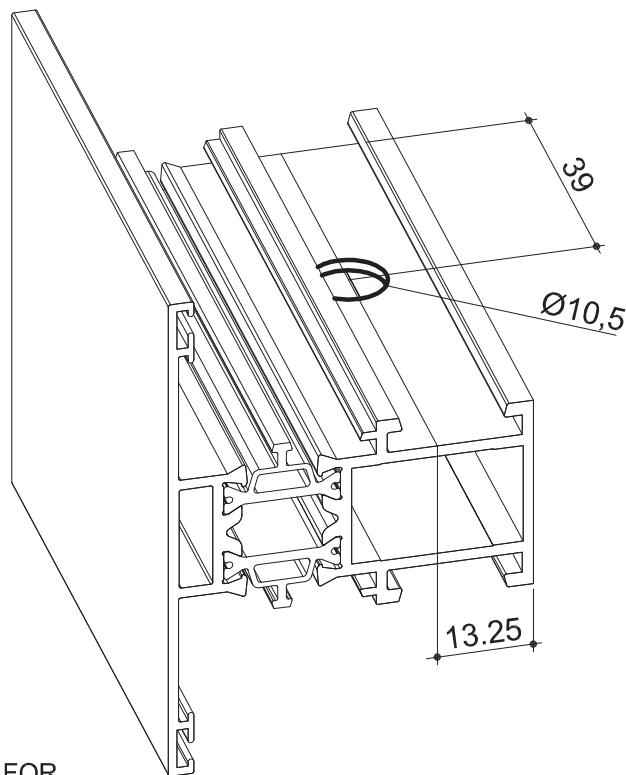

4

Ø10.5mm HOLE FOR CLAMP FASTENING

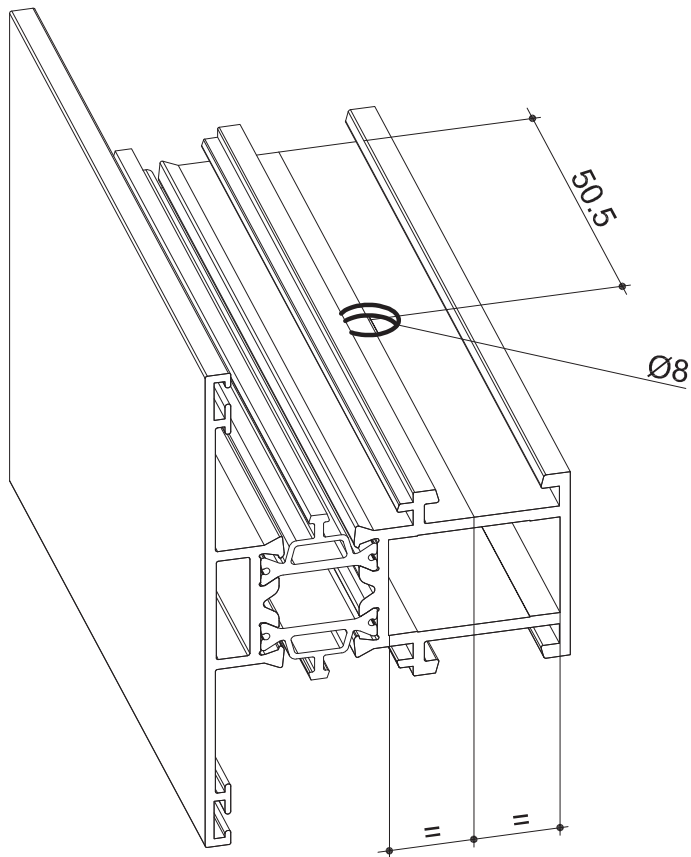

5

Ø 8 mm HOLE FOR CLAMP FASTENING

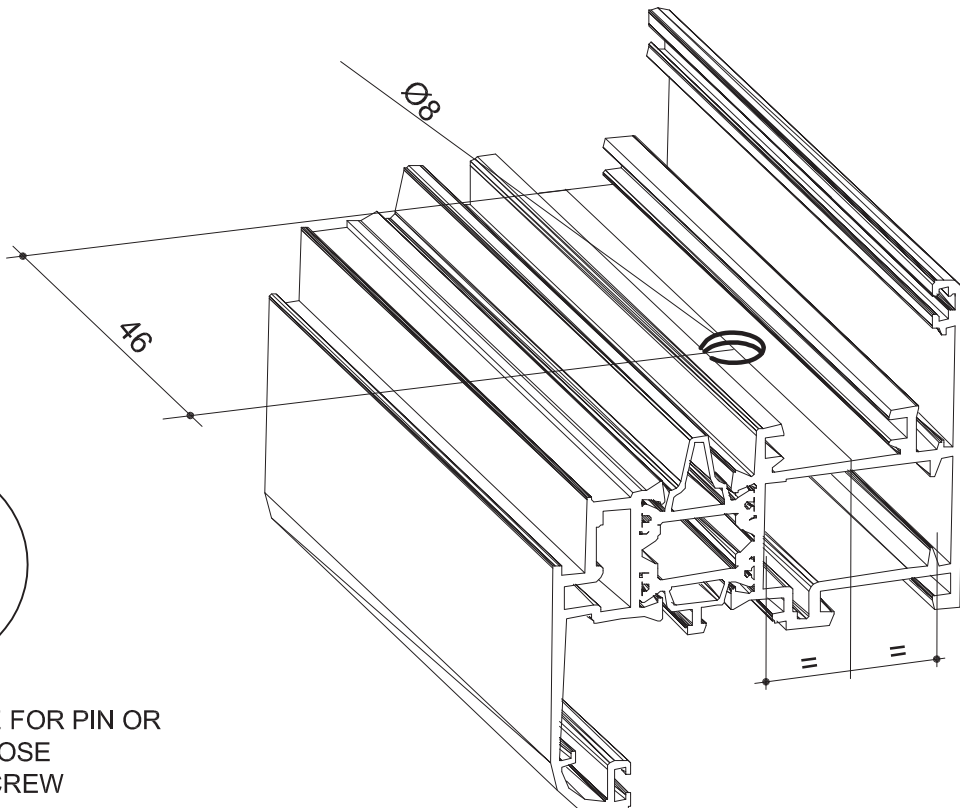

6

Ø8 mm HOLE FOR PIN OR MULTI-PURPOSE BRACKET SCREW

7

SLOT AND PASSING HOLE FOR GLOBAL SLIDING CONNECTION FRAME

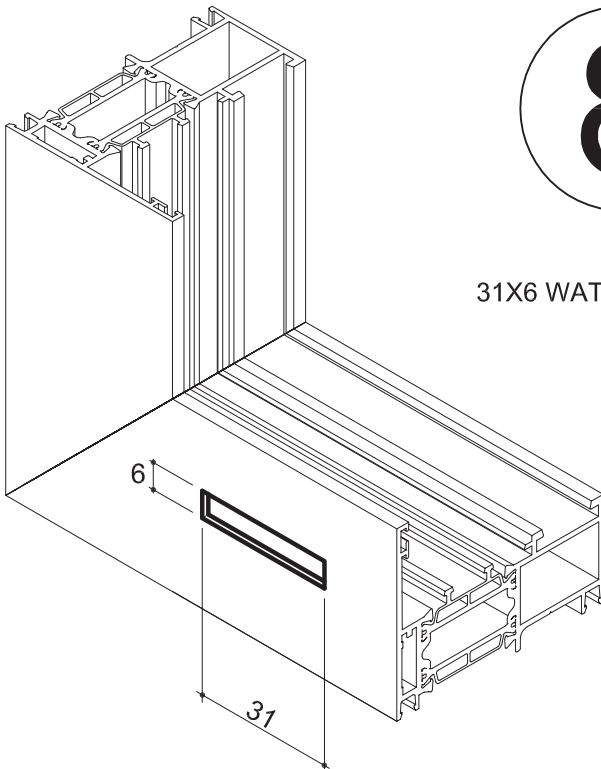
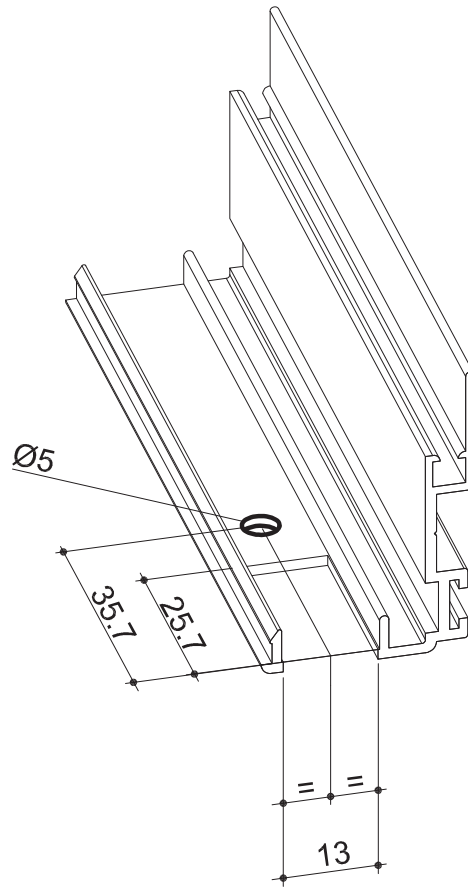

8

31X6 WATER DRAINAGE

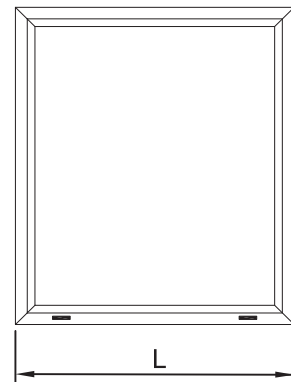

DIMENSIONS L	QUANTITY DRAINAGES
UP TO 1000	2
FROM 1000 TO 1500	3
OVER 1500	4

9

TRIMMINGS OF ROD
PASSAGE FINS

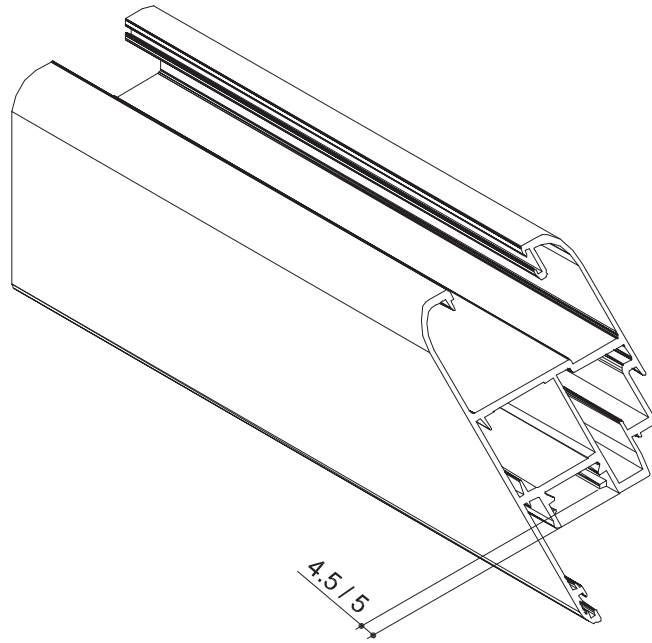

10

PREARRANGEMENT TO
FIT GLOBAL SLIDING
INSET HANDLE

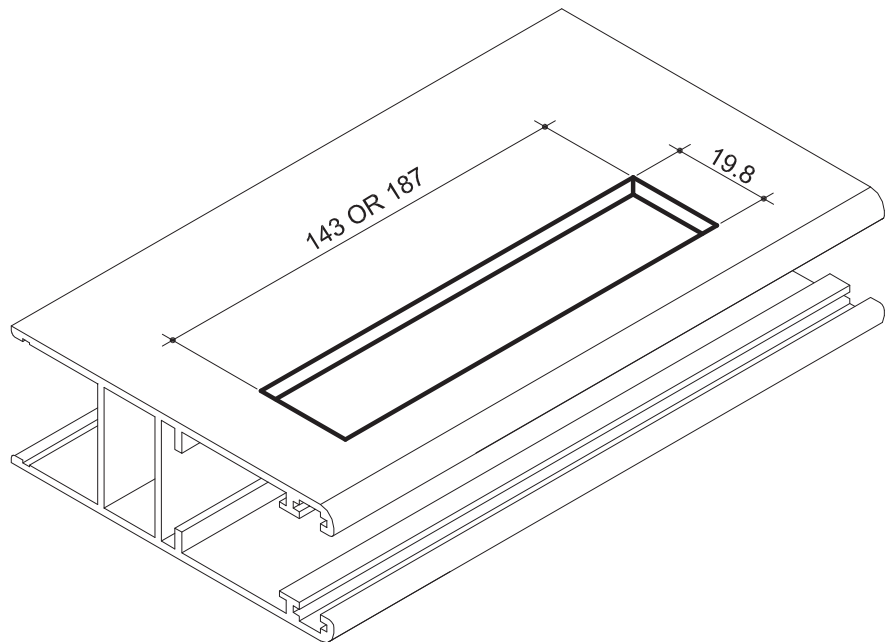

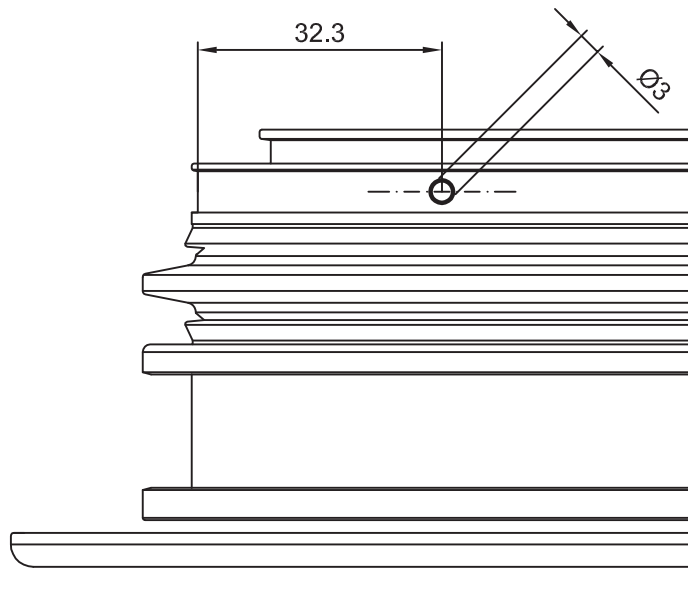
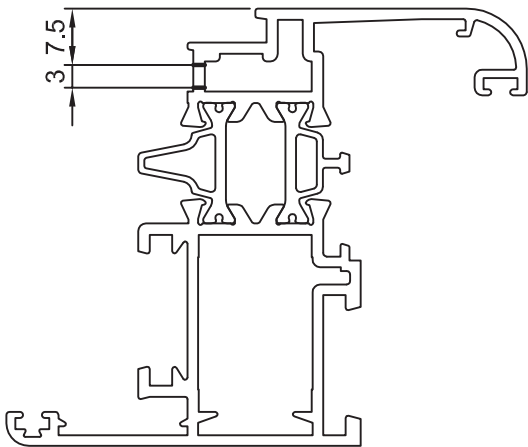

11

Ø 3 mm HOLE FOR PIN
ACP 5030 BRACKET ACP
50153, ACP 50154

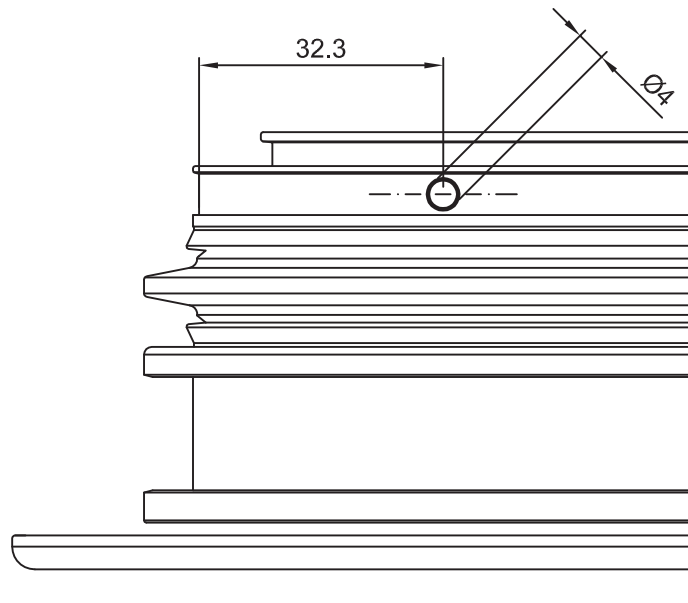
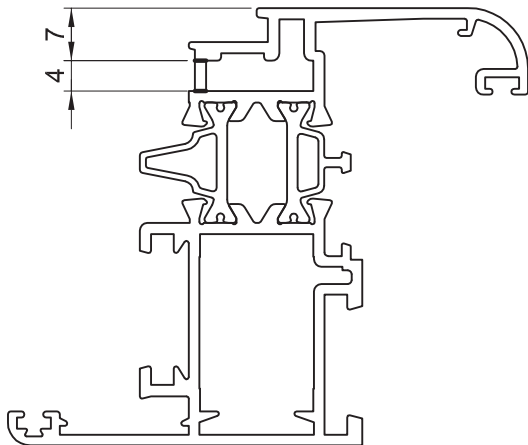

12

Ø 4 mm HOLE FOR SCREW
ACP 50155 BRACKET ACP
50153, ACP 50154

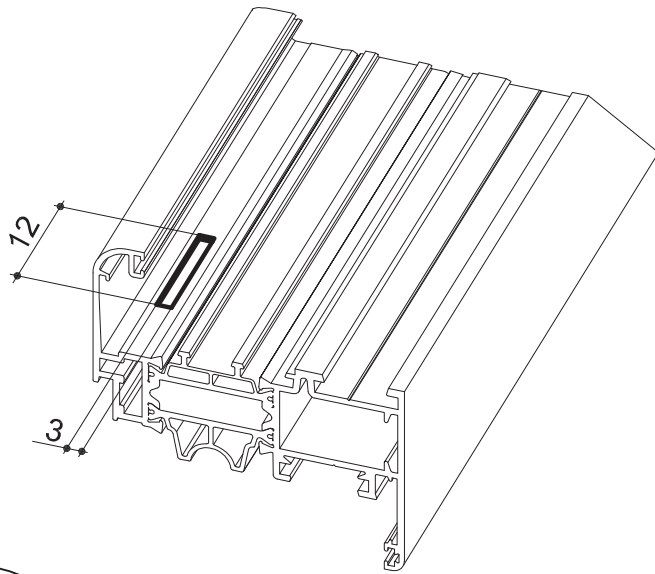

13

INTERNAL SLOT FOR LEAF VENTILATION

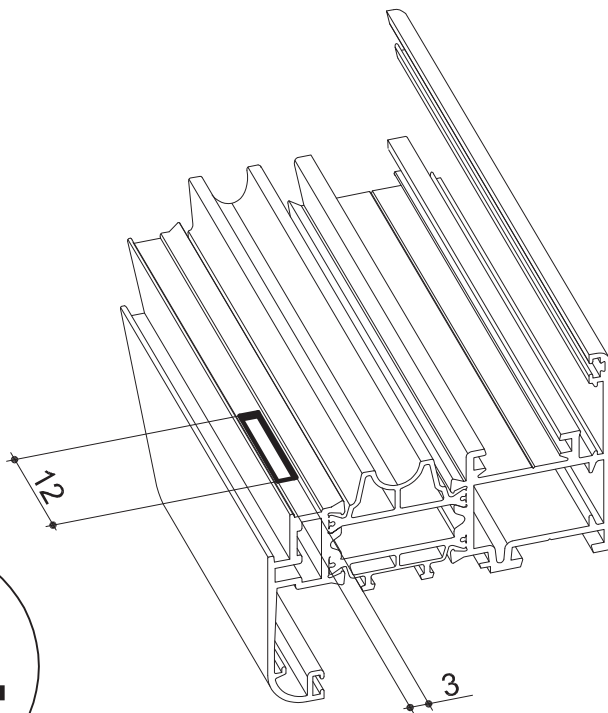
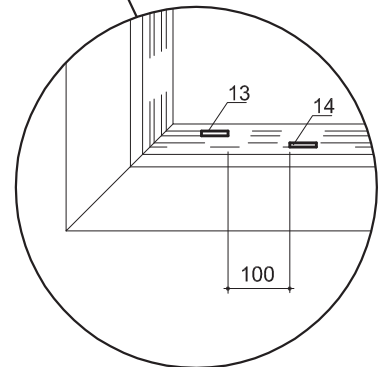
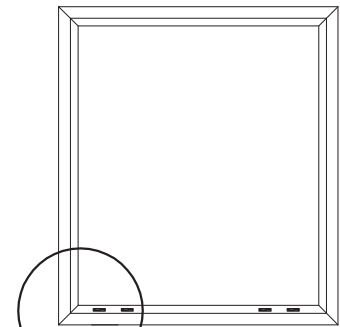

14

EXTERNAL SLOT FOR LEAF VENTILATION

Cutter unit MCT PL 08 PT

This cutter unit works on all Planet 50 and Planet 62 profiles except for those for the 58mm, 70mm smooth leaves and beadless glazing

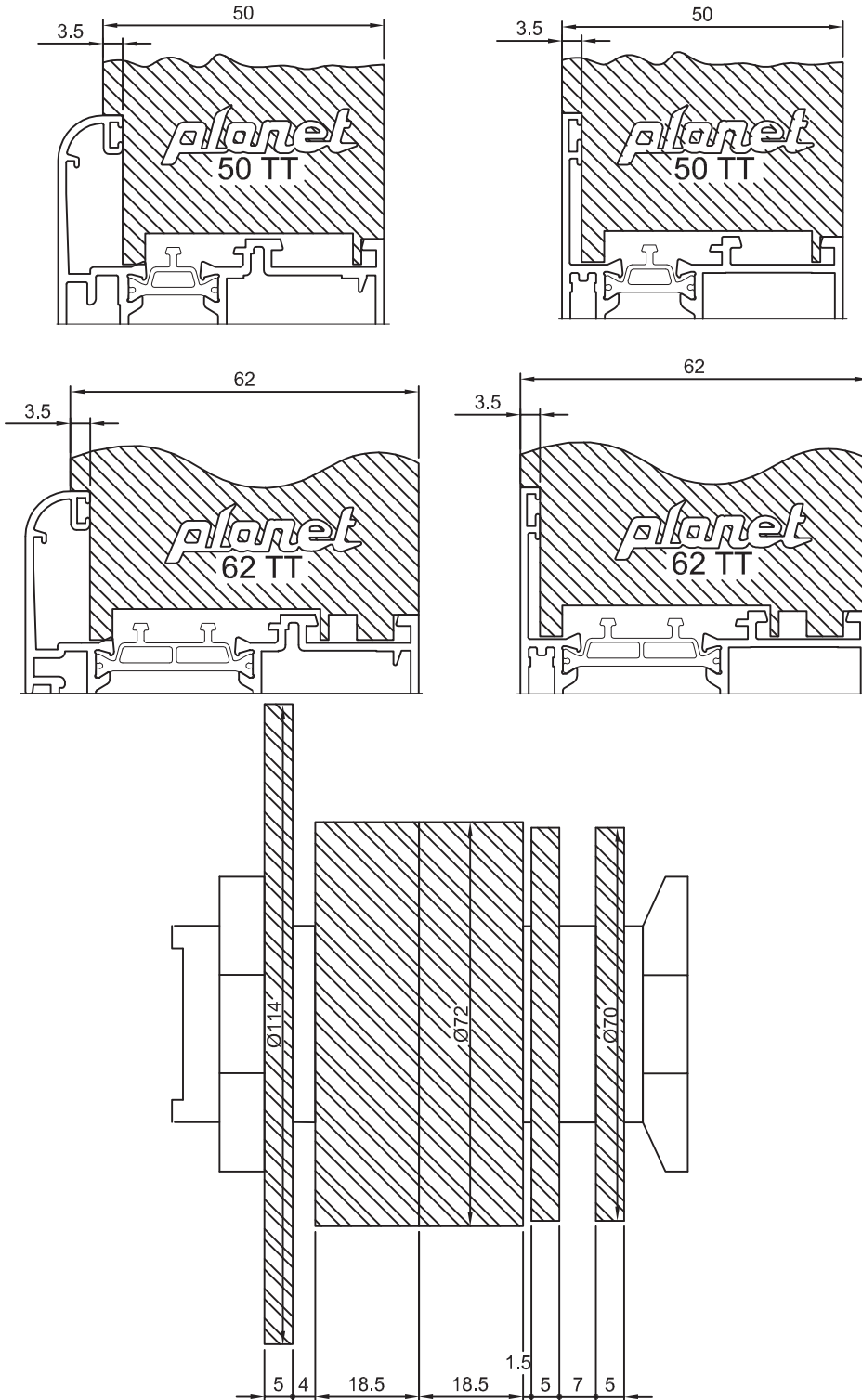

cutter unit MCT PL 08 PT

this cutter unit works exclusively on the profiles for smooth leaves in the Planet 50 58mm and planet 62 70mm ranges

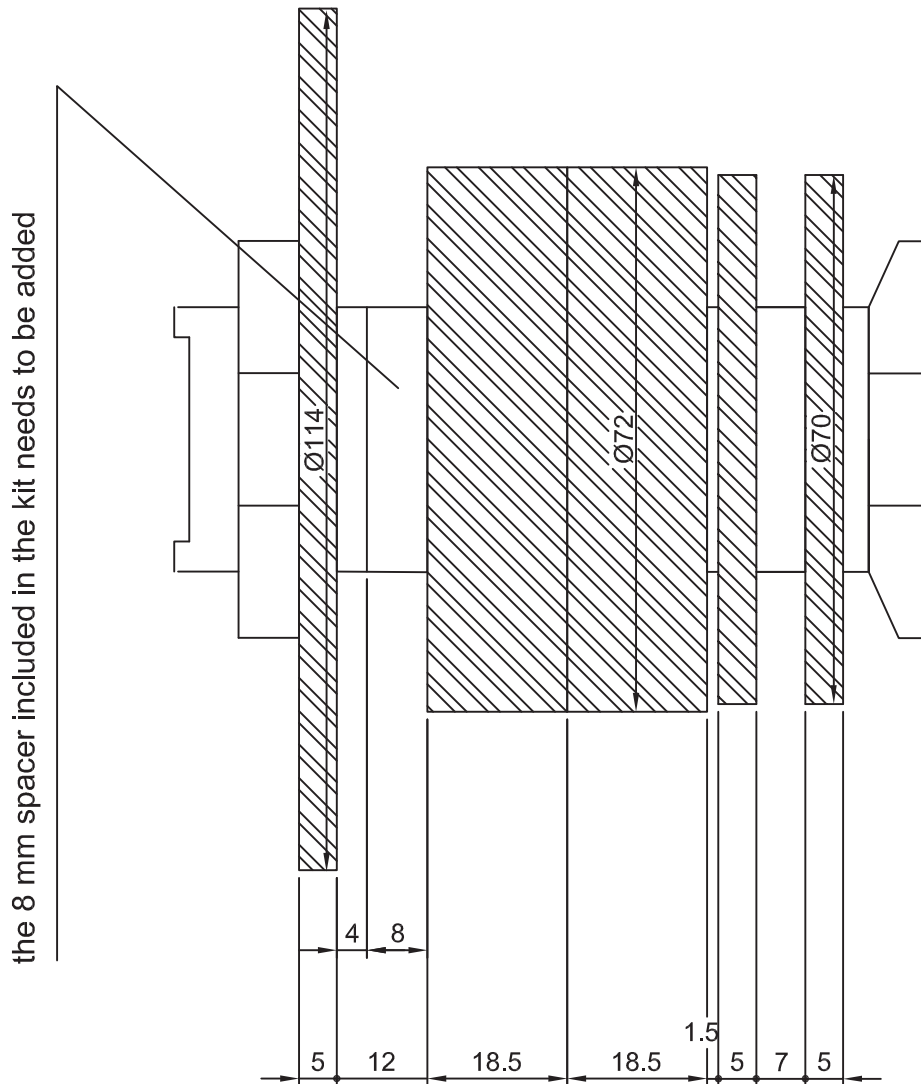
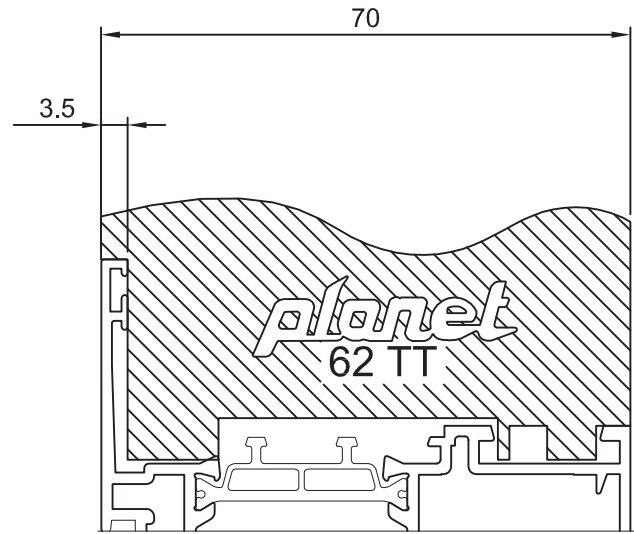
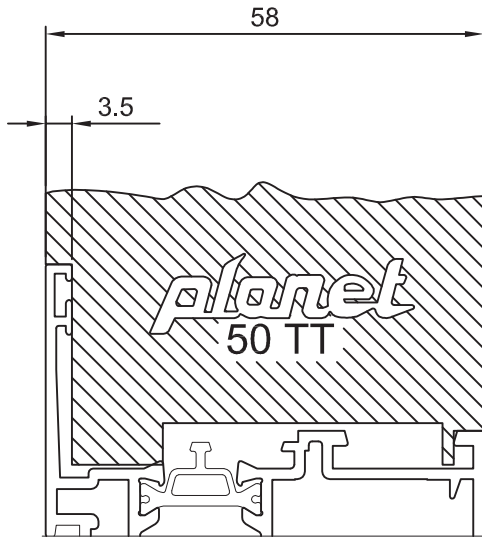

cutter unit MCT PL 06 PT

this cutter unit works exclusively on the profiles for the glass insert leaves in the planet 50TT/62TT range with glass space 30mm

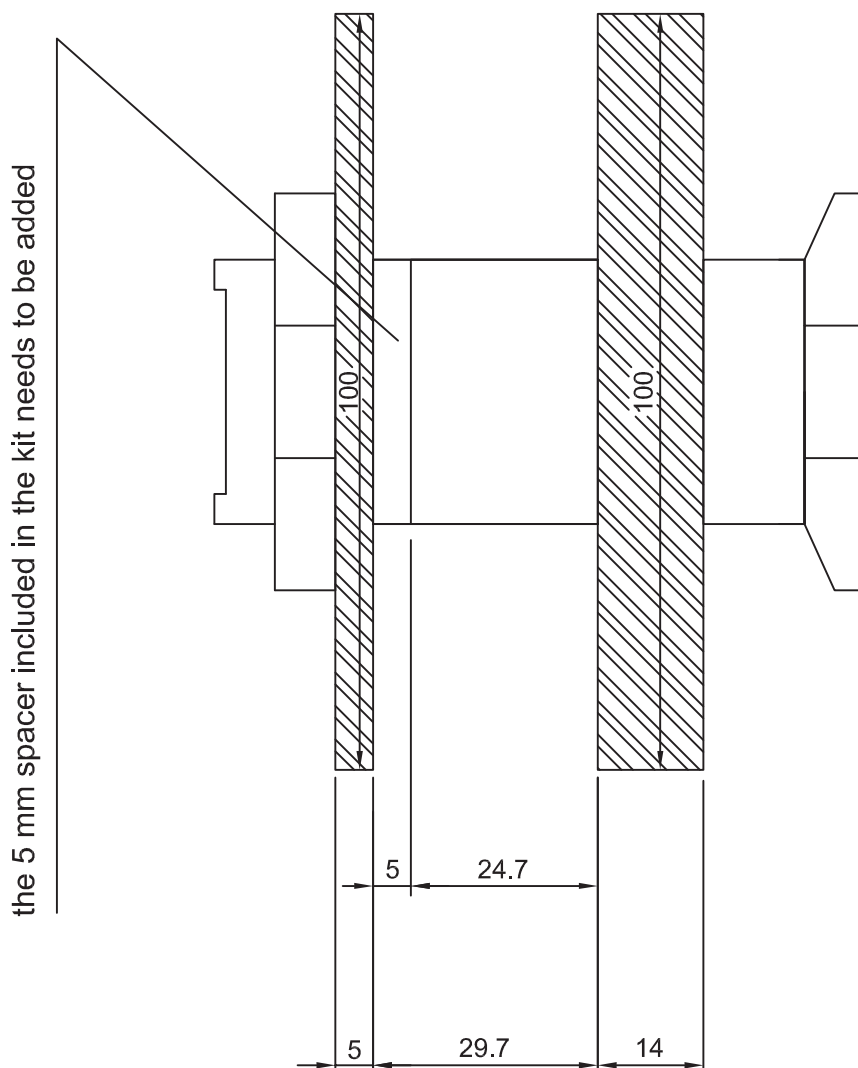
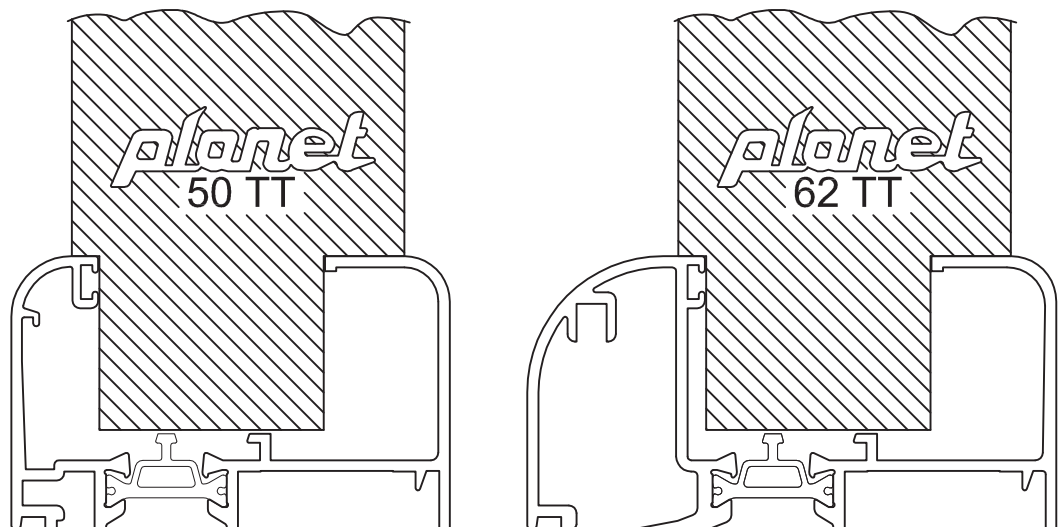

machining of single-unit shoulder

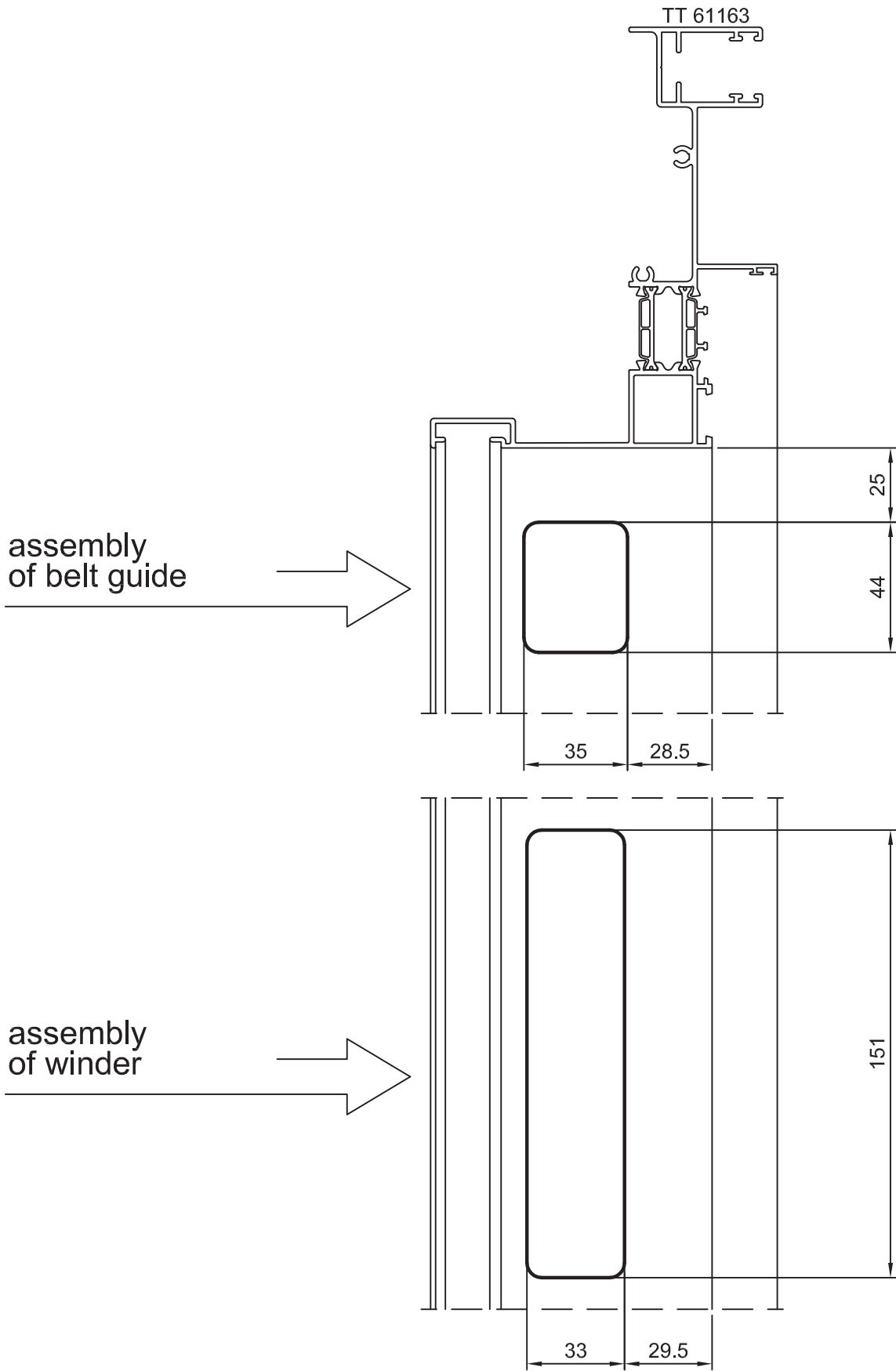

**QUICK-FIT DOOR 2-WING
HINGE ACP 5018**

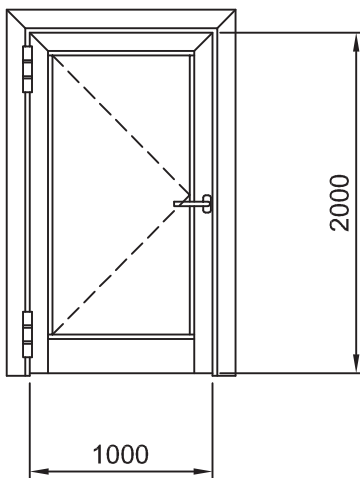
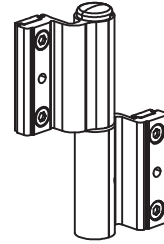
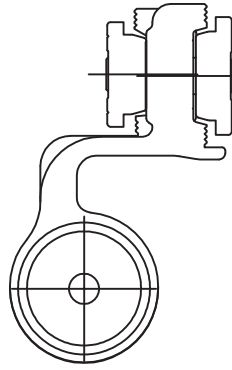

Type	Capacity
Doors for residential use	100 Kg
Doors for public use	90 Kg
Doors for public use with door closer	80 Kg

1. The hinges must be mounted at the upper and lower ends of the door
2. The height/width ratio of the door must be greater than or equal to 2.
For lower height/width ratios, the capacity is reduced by 10 % for every 0.1 reduction in ratio.
3. Increase in capacity for third hinge fitted at the top, near to the upper hinge: 15 %.
No increase in capacity for third hinge mounted at the centre of the door.
4. Under no circumstances must the door exceed the dimension and weight limits of the profile indicated by Al sistem.

**QUICK-FIT DOOR 3-WING
HINGE ACP 5028**



0049
CPD 40-720012
EN 1935:2002
31714101141111

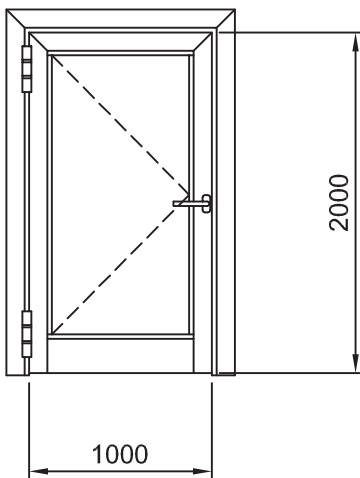
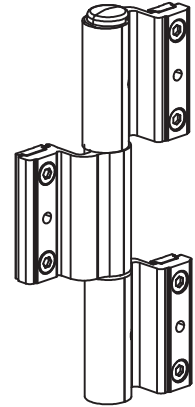
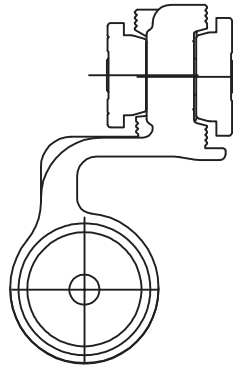

Type	Capacity
Doors for residential use	120 Kg
Doors for public use	110 Kg
Doors for public use with door closer	100 Kg

1. The hinges must be mounted at the upper and lower ends of the door
2. The height/width ratio of the door must be greater than or equal to 2.
For lower height/width ratios, the capacity is reduced by 10 % for every 0.1 reduction in ratio.
3. Increase in capacity for third hinge fitted at the top, near to the upper hinge: 15 %.
No increase in capacity for third hinge mounted at the centre of the door.
4. Under no circumstances must the door exceed the dimension and weight limits of the profile indicated by Al sistem.

2-WING FRONT FITTED DOOR
HINGE ACP 5064/60 and ACP
5064/93



0333
CPD 40-720015
EN 1935:2002 + AC:2003
41710114114

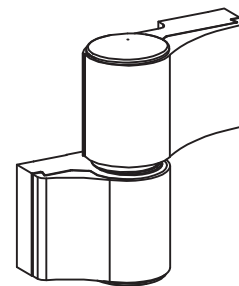
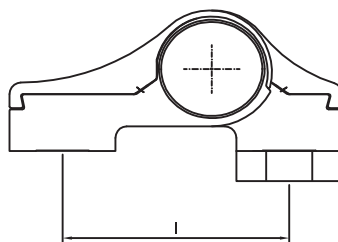

centre distance I from 41 mm to 99 mm

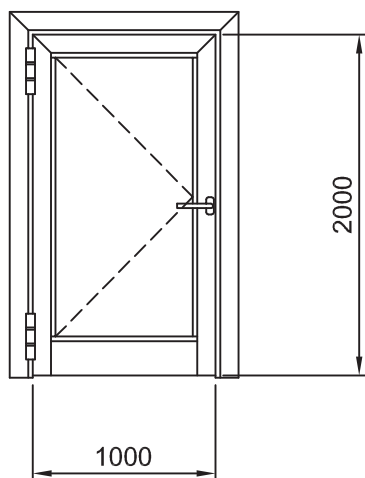

Type	Capacity
Doors for residential use	160 Kg
Doors for public use	145 Kg
Doors for public use with door closer without brake	130 Kg
Doors for public use with door closer with brake	115 Kg

1. The hinges must be mounted at the upper and lower ends of the door
2. The height/width ratio of the door must be greater than or equal to 2.
For lower height/width ratios, the capacity is reduced by 10 % for every 0.1 reduction in ratio.
3. Increase in capacity for third hinge mounted at the top, near to the upper hinge: 15 %.
No increase in capacity for third hinge mounted at the centre of the door.
4. Under no circumstances must the door exceed the dimension and weight limits of the profile indicated by AI sistem.
5. For applications with spacers, the capacity is reduced by 15 %.

3-WING FRONT FITTED DOOR
HINGE ACP 5064/60 and ACP
5064/93



0049
CPD 40-720012
EN 1935:2002
374014111

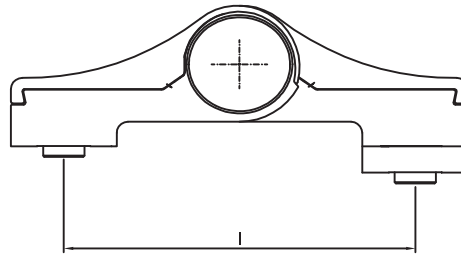

centre distance I from 41 mm to
99 mm

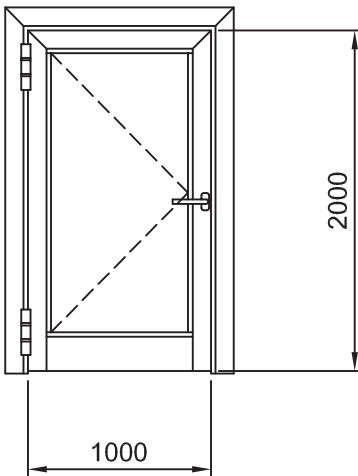
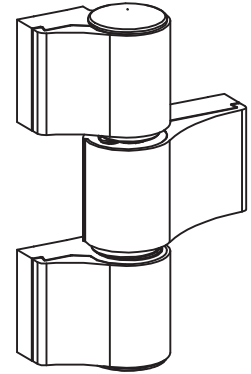

Type	Capacity
Doors for residential use	160 Kg
Doors for public use	150 Kg
Doors for public use with door closer without brake	140 Kg
Doors for public use with door closer with brake	130 Kg

1. The hinges must be mounted at the upper and lower ends of the door
2. The height/width ratio of the door must be greater than or equal to 2.
For lower height/width ratios, the capacity is reduced by 10 % for every 0.1 reduction in ratio.
3. Increase in capacity for third hinge mounted at the top, near to the upper hinge: 15 %.
No increase in capacity for third hinge mounted at the centre of the door.
4. Under no circumstances must the door exceed the dimension and weight limits of the profile indicated by Al sistem.

application of front hinges ACP 5064/60 and ACP 5063/60
centre distance 60mm

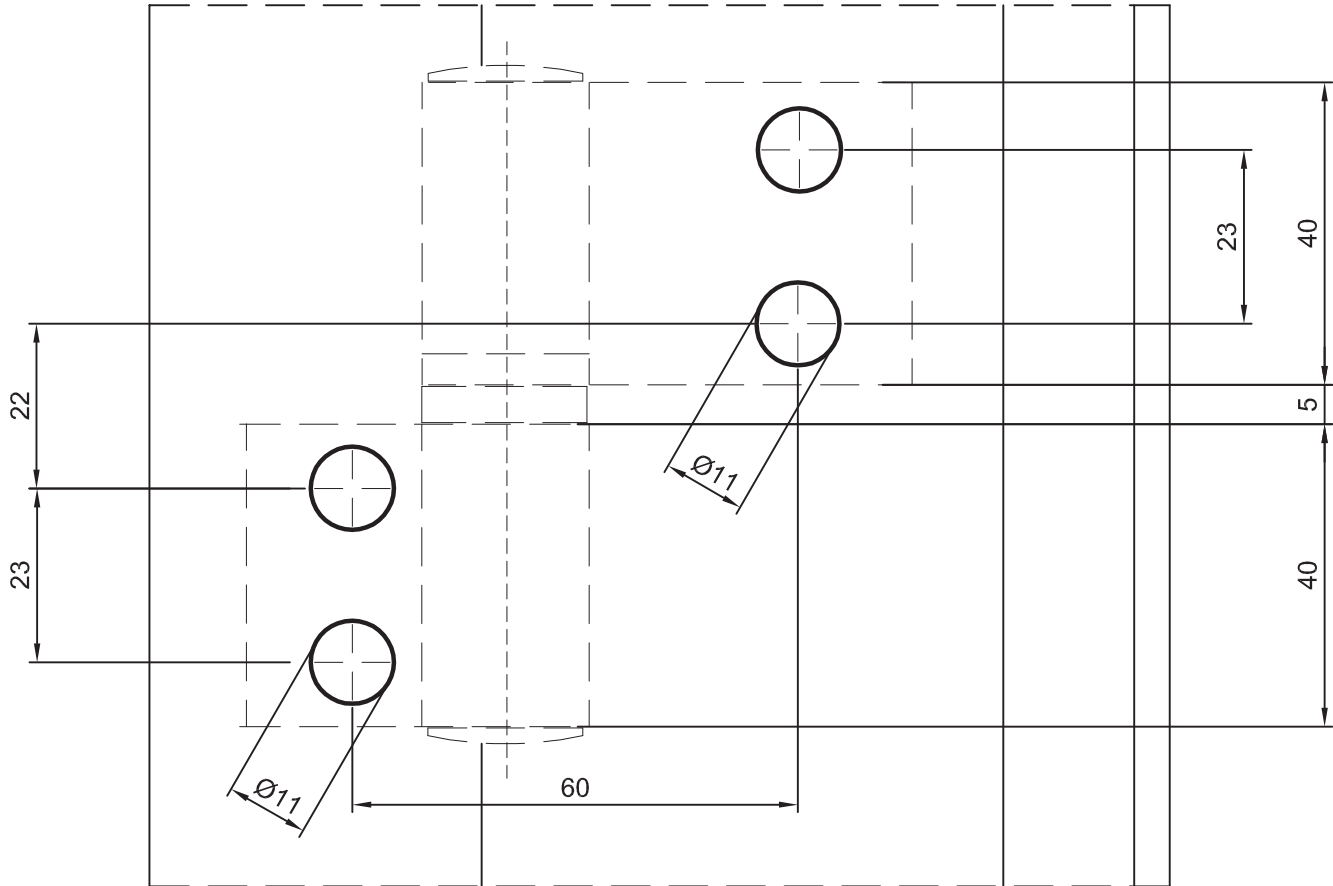

TT 6133

TT 6117

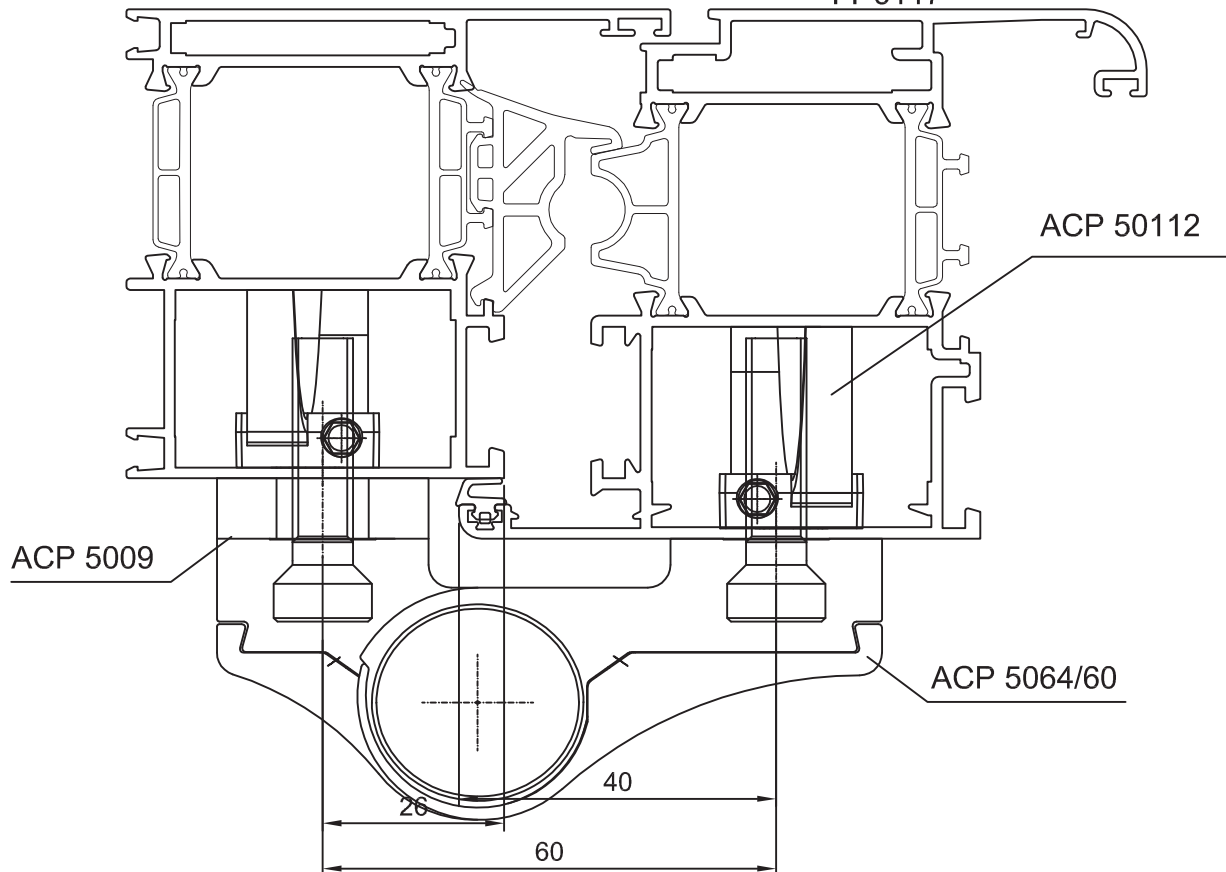

application of front hinges ACP 5064/93 and ACP 5063/93
centre distance 93mm

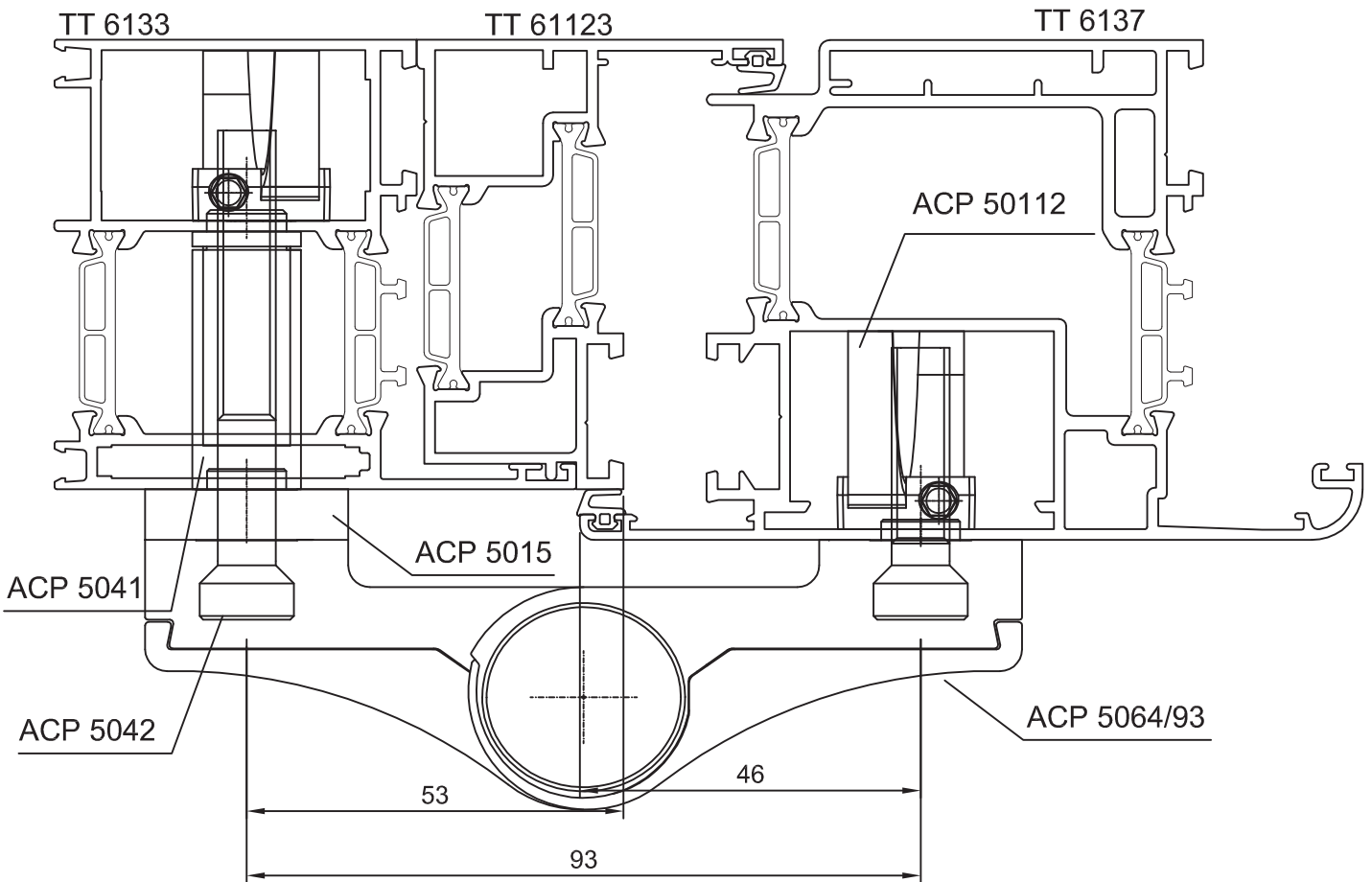
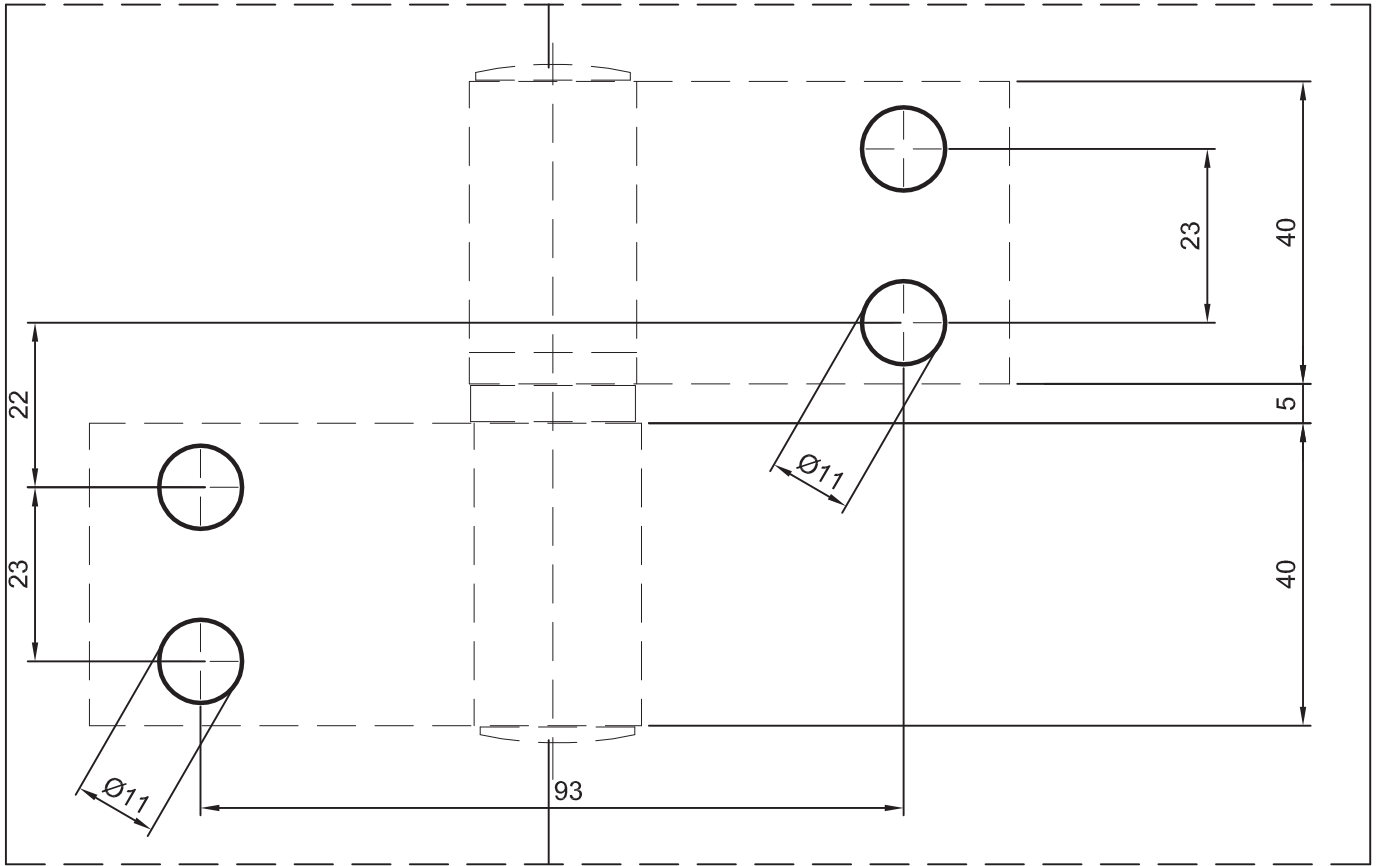

application ACP 50153 – ACP 50154

application ACP 50153 - ACP 50154

profile holes with punching machine MCT PL JOLLY. Insert bracket ACP 50153 - ACP 50154 and close the corner by choosing from the following options:

- 1) crimping using the appropriate kit
- 2) broaching using pin ACP 5030 with disposable stem \varnothing 3 hole
- 3) screwing with screw ACP 50155 \varnothing 4 hole (cannot be used on frame profiles).

HOLE CENTRE DISTANCE: mm 32.3

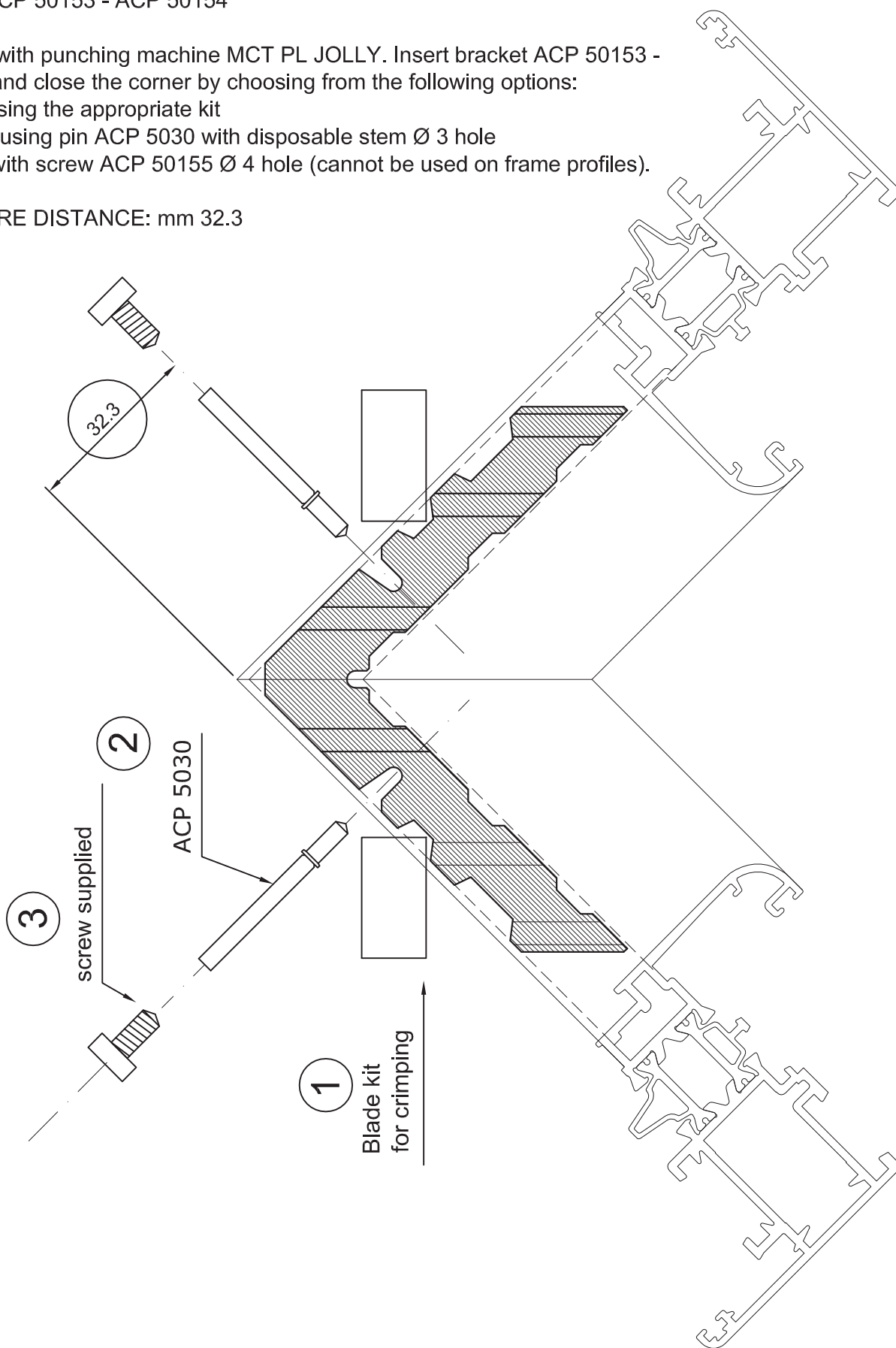

application ACP 5801 – ACP 5802 – ACP 7001

Foapplication ACP 5801 - ACP 5802 - ACP 7001

Pre-pin holes with punching machine. D=8 mm. (machining no.6)

Insert bracket ACP 5801 and close the corner by choosing from the following options:

- 1) crimping using the appropriate kit
- 2) broaching using pin ACP 5800.
- 3) screwing with screw ACP 5001.

HOLE CENTRE DISTANCE: mm 46

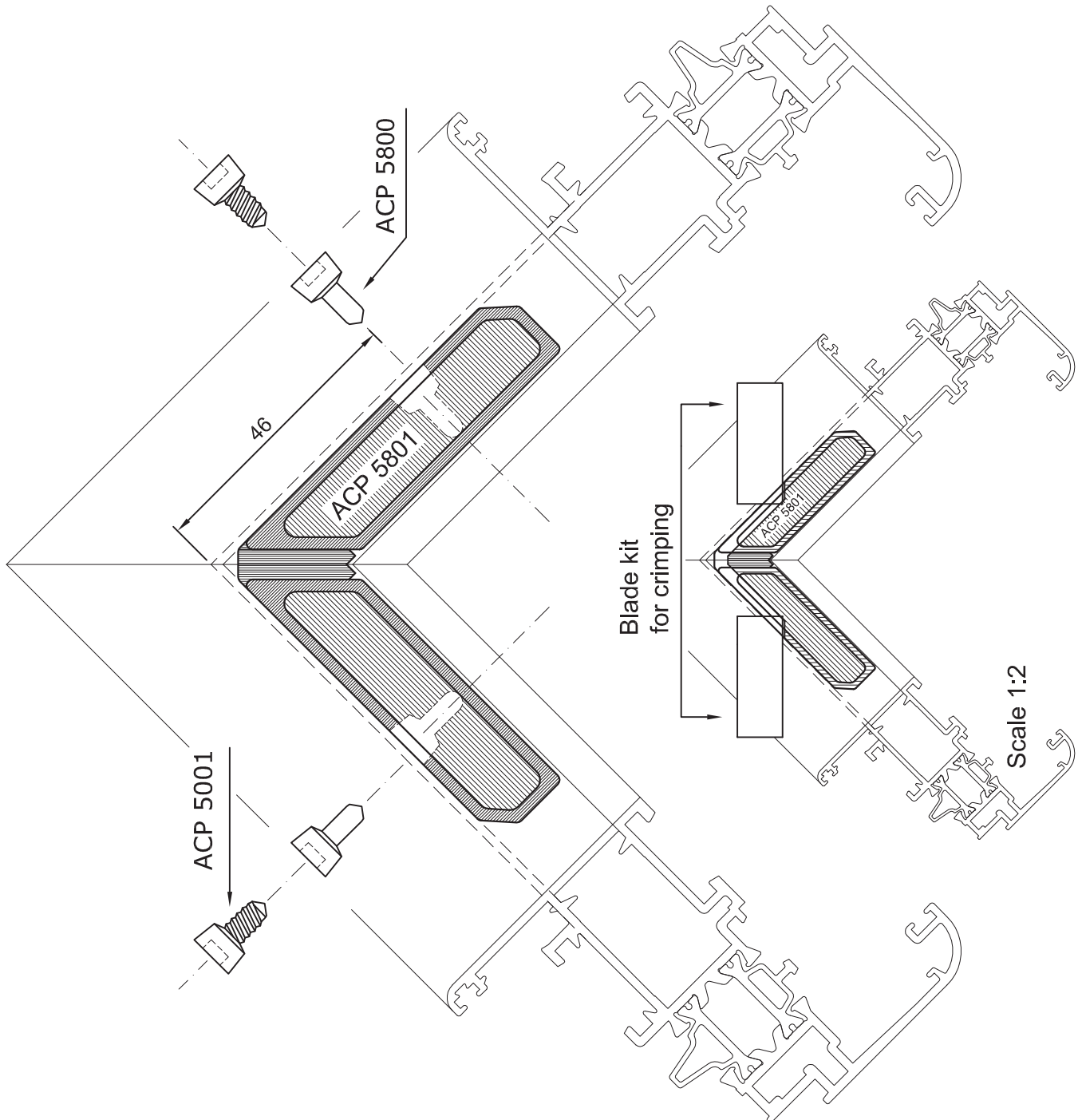

machining of holes to fit variable corner brackets ACP 5504 / ACP 5805:

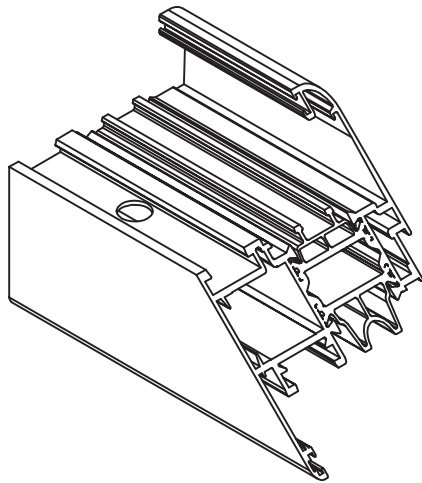

Procedure for ACP 5504

- Once the profile cut angle has been established, measure value A or determine it theoretically by applying the following formula $A = B \times \tan(\text{alfa})$
- Add to or subtract from the coefficient C half of value A (previously determined) to obtain the external drilling distance X1 or the internal drilling distance X2
- Given the wide range of adjustment of the brackets the measurement obtained can be rounded + 0 - to the mm.

Procedure for ACP 5805

- For this bracket the same rules apply for the calculation of A, whereas for X1 the coefficient to be added is always 41 mm.

THEREFORE:

$$X1 = A + 41$$

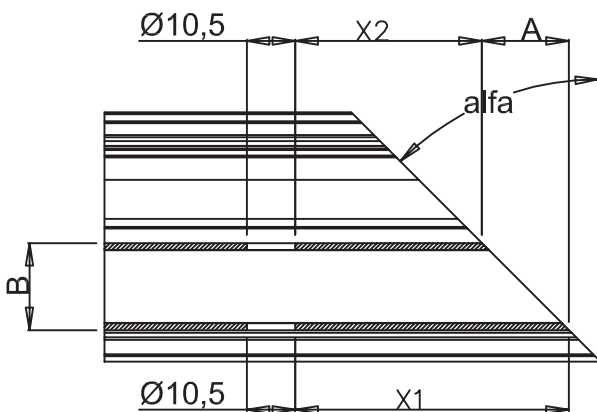

Angle = alfa
 $A = B \times \tan(\text{alfa})$
 $C = 65$
 $X1 = C + (A/2)$
 $X2 = C - (A/2)$

Example with cutting angle $\text{alfa} = 55^\circ$

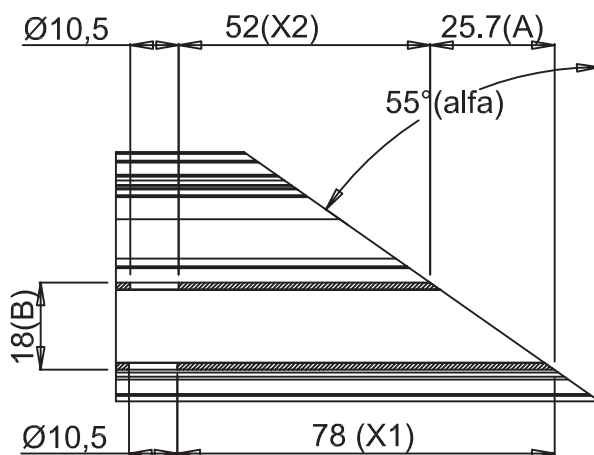

Angle = 55
 $A = 18 \times (\tan \text{ di } 55)$
 $C = 65 \text{ (art. 0910.10)}$
 $X1 = 65 + (25.71/2) = 77.85 \text{ circa}$
 $X2 = 65 - (25.71/2) = 52.15 \text{ circa}$
 round up/down
 $X1 = 78$
 $X2 = 52$

sloping wall spacer

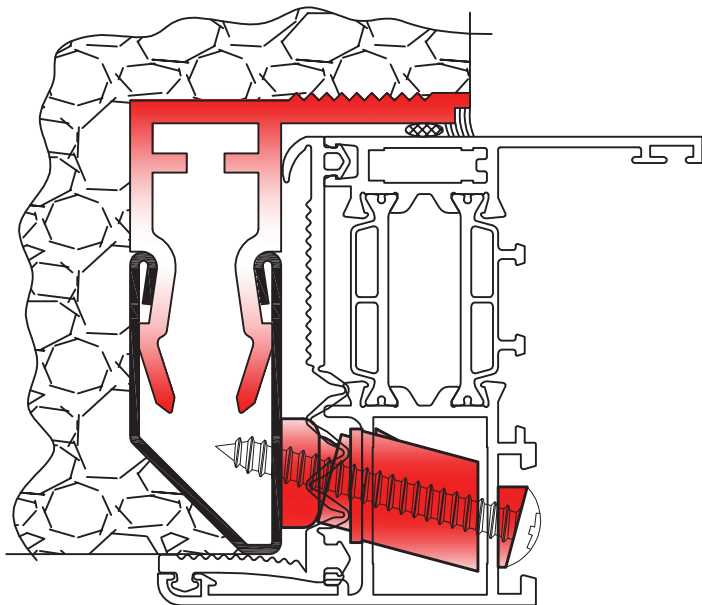

for a correct and safe fixing to the counter-frame it is always necessary to use the wall spacer.

The sloping spacer ACP 50536 can be used on Planet frames with a standard chamber . This spacer prevents the plaster from cracking as a result of too peripheral a fixing caused by normal guides

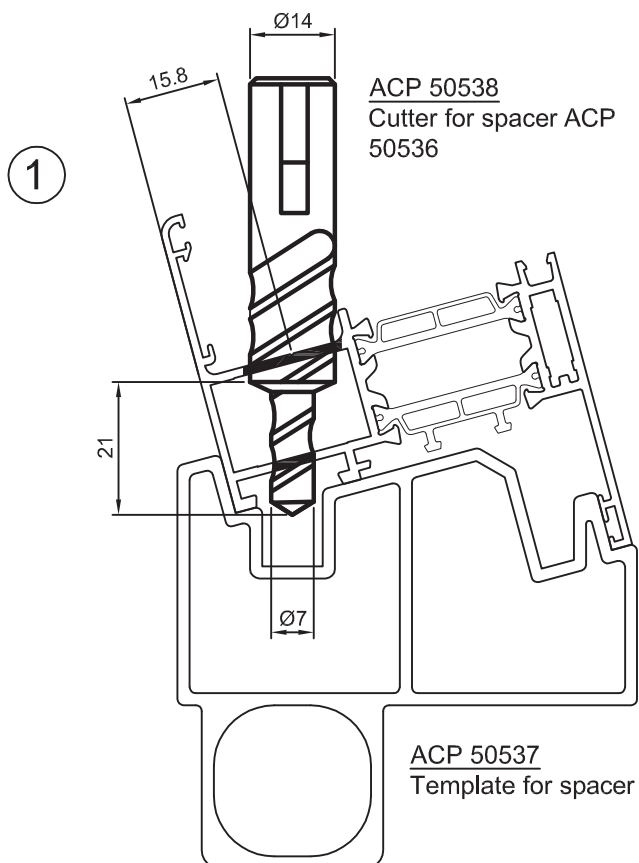

Make a hole in the tubularity of the frame with cutter ACP 50538, using template ACP 50537 as a support base

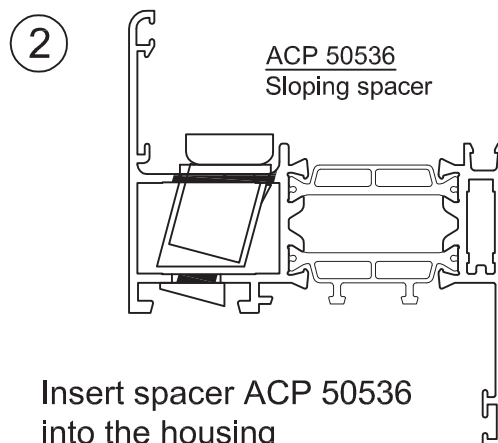

Leaf closure rod cutting

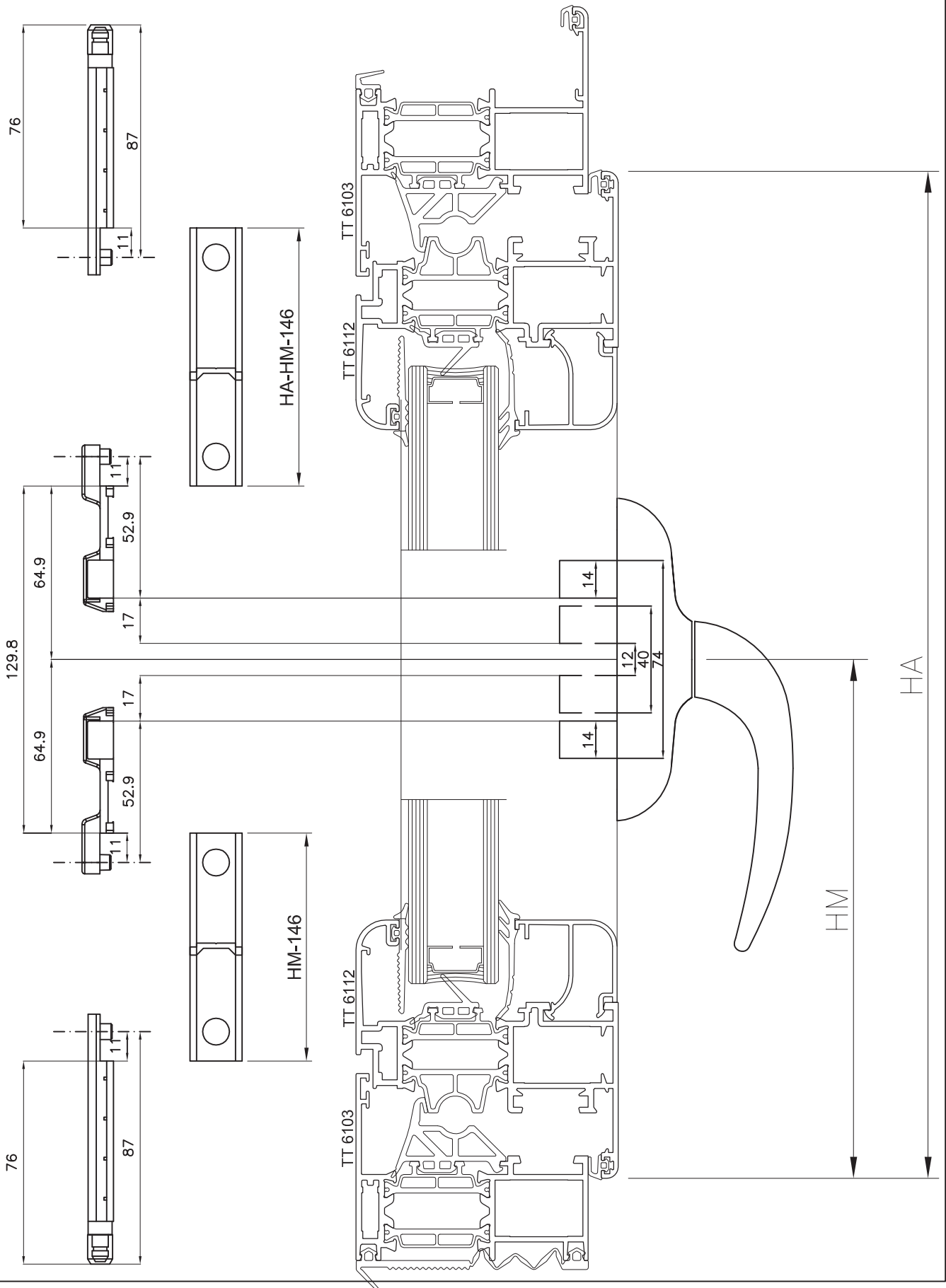

Fitting the central connection profile cap

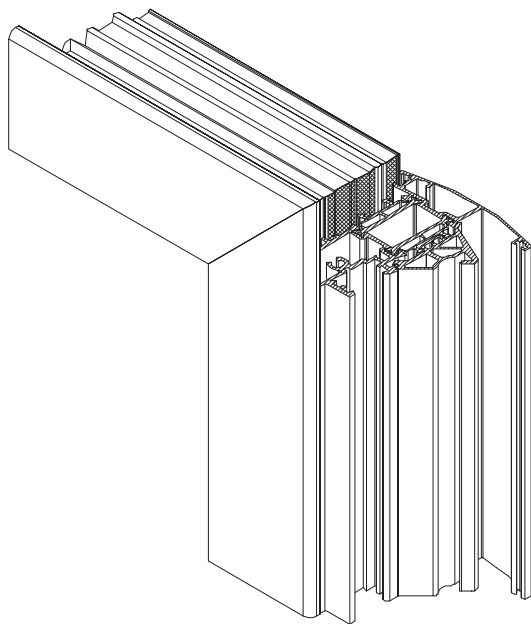

Seal the areas shown in the drawing before fitting the central connection profile cap

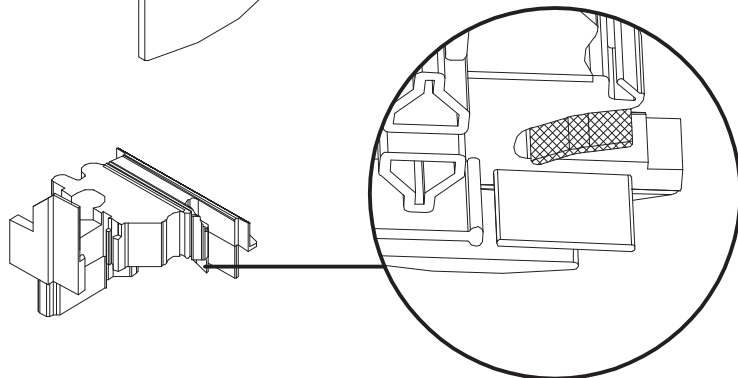
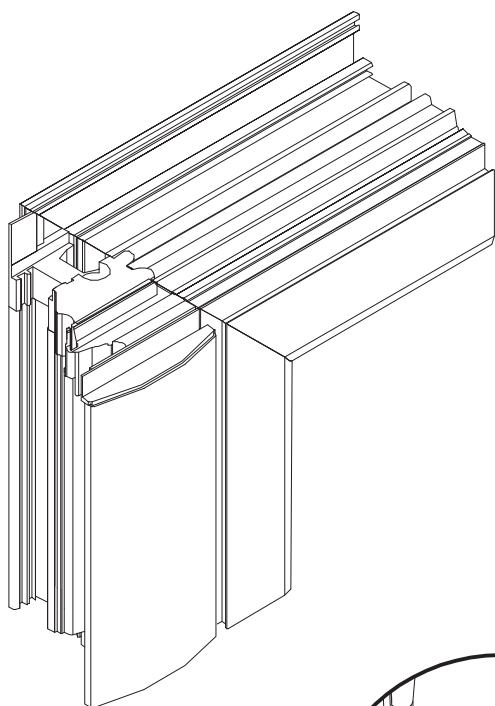
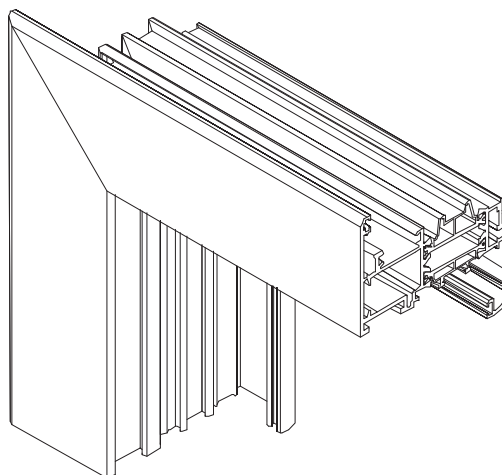

After fitting the cap, place the central fin, gluing the contact area.

Assembly of glazing bead angles

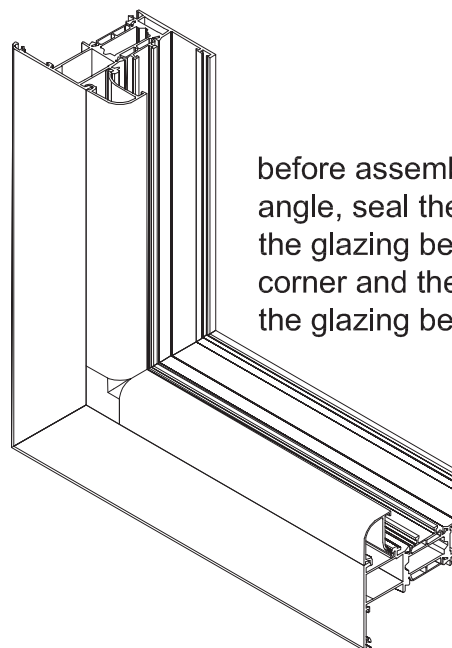
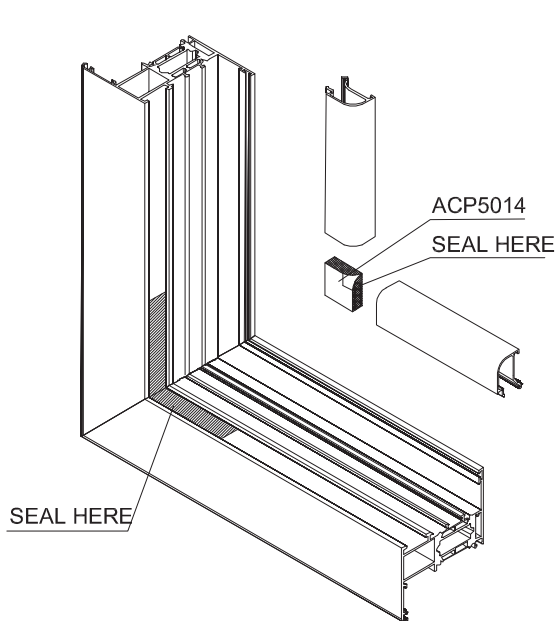

before assembling the angle, seal the housing of the glazing bead in the corner and the joints with the glazing beads

assembly of anti-roll plate

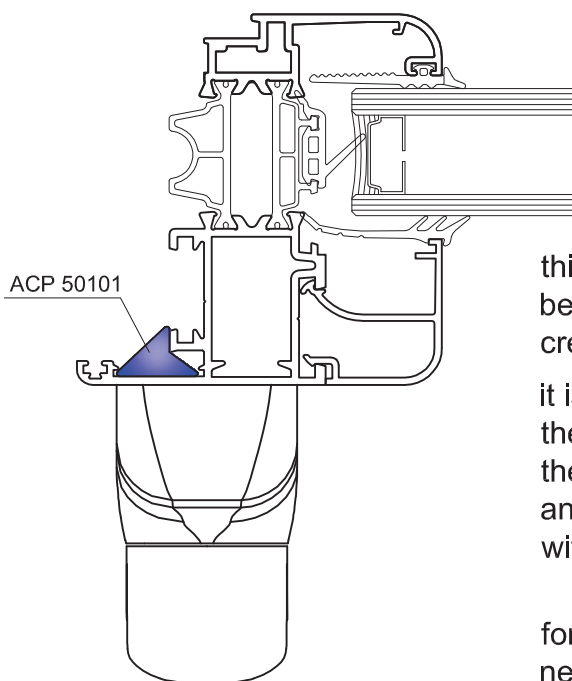

this accessory gives better stability to the cremone bolt

it is applied in place of the plate supplied with the cremone bolt itself and sold separately with code ACP 50101

for some profiles it is necessary to use longer fastening screws



assembly of vulcanised corner

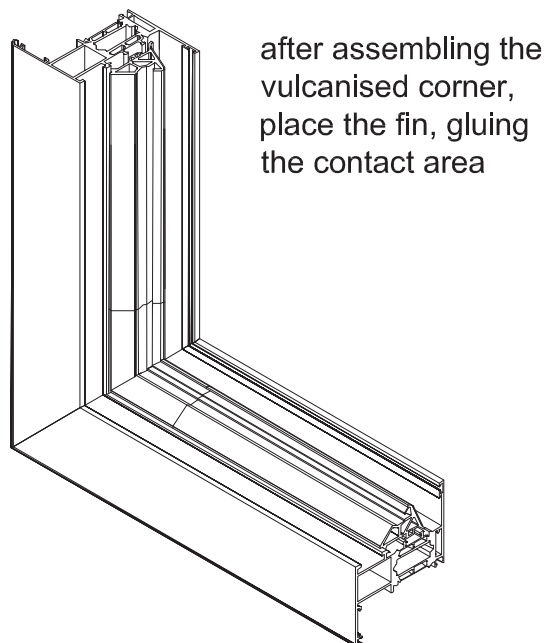
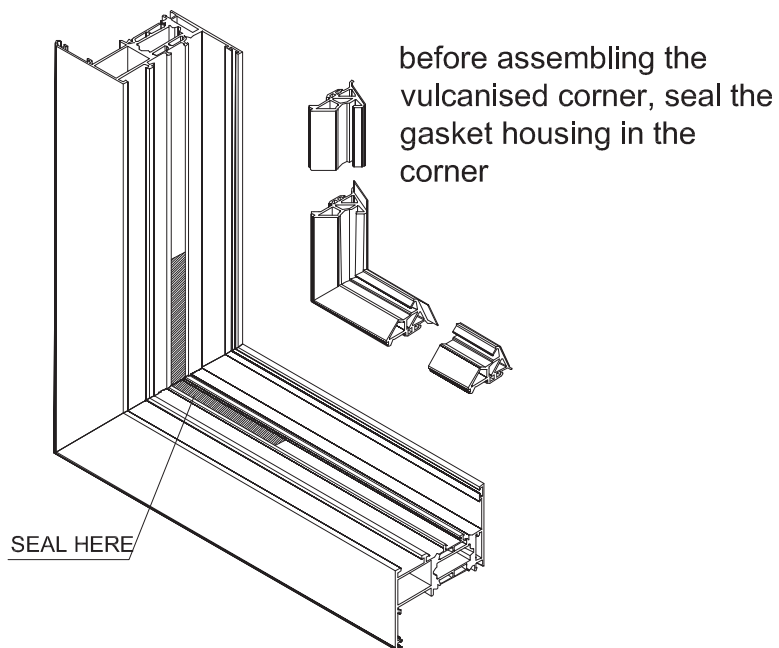

assembly of vulcanised corner for sill:

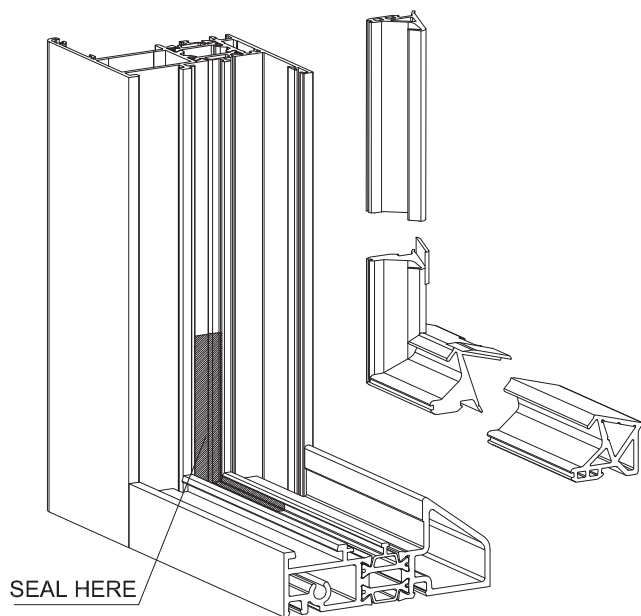

before assembling the vulcanised corner, seal the housing of the gasket in the corner

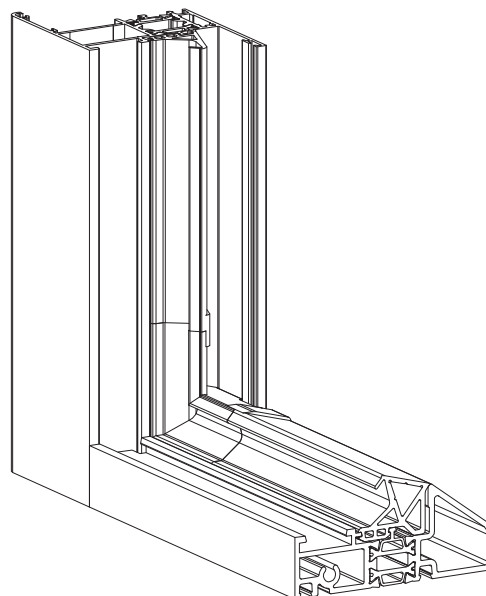

after assembling the vulcanised corner, place the fin, gluing the contact areas

application of support and insulation of glass on the leaf profiles

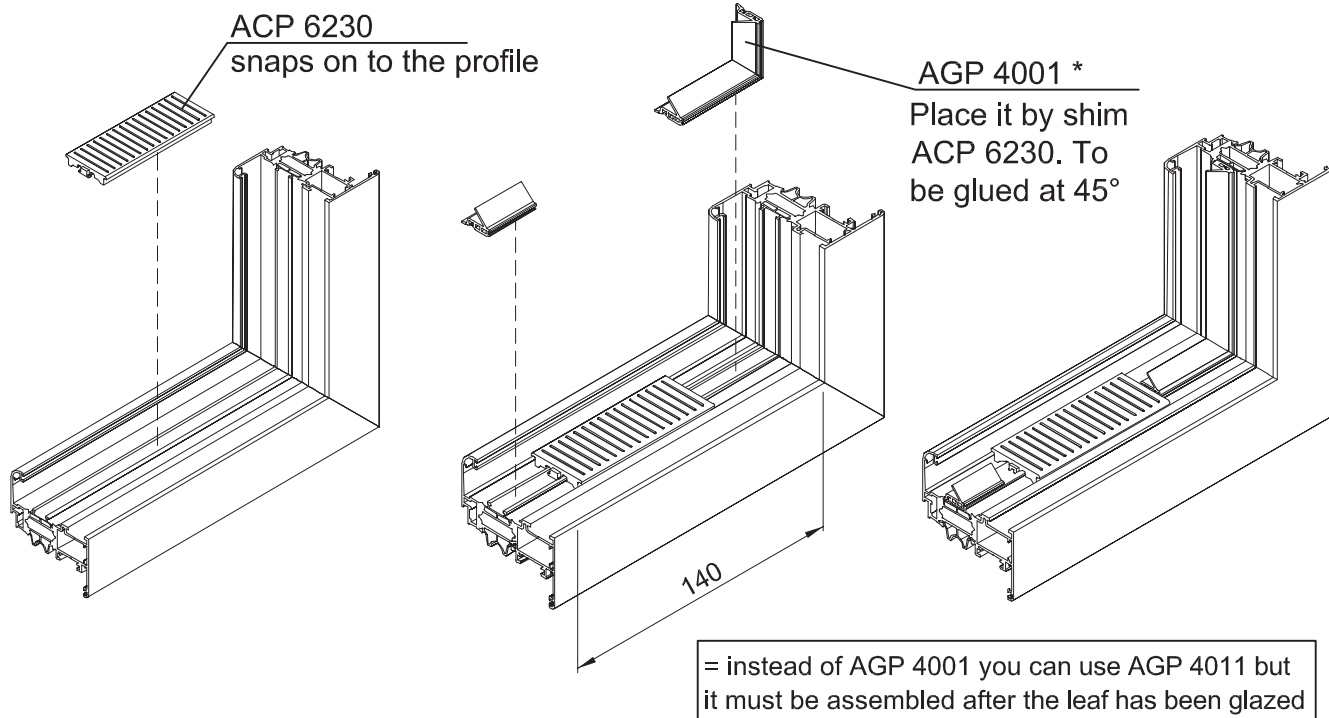
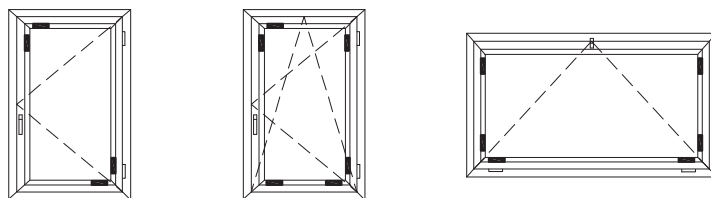

application of support and insulation of glass on the frame profiles in the case of fixed glass

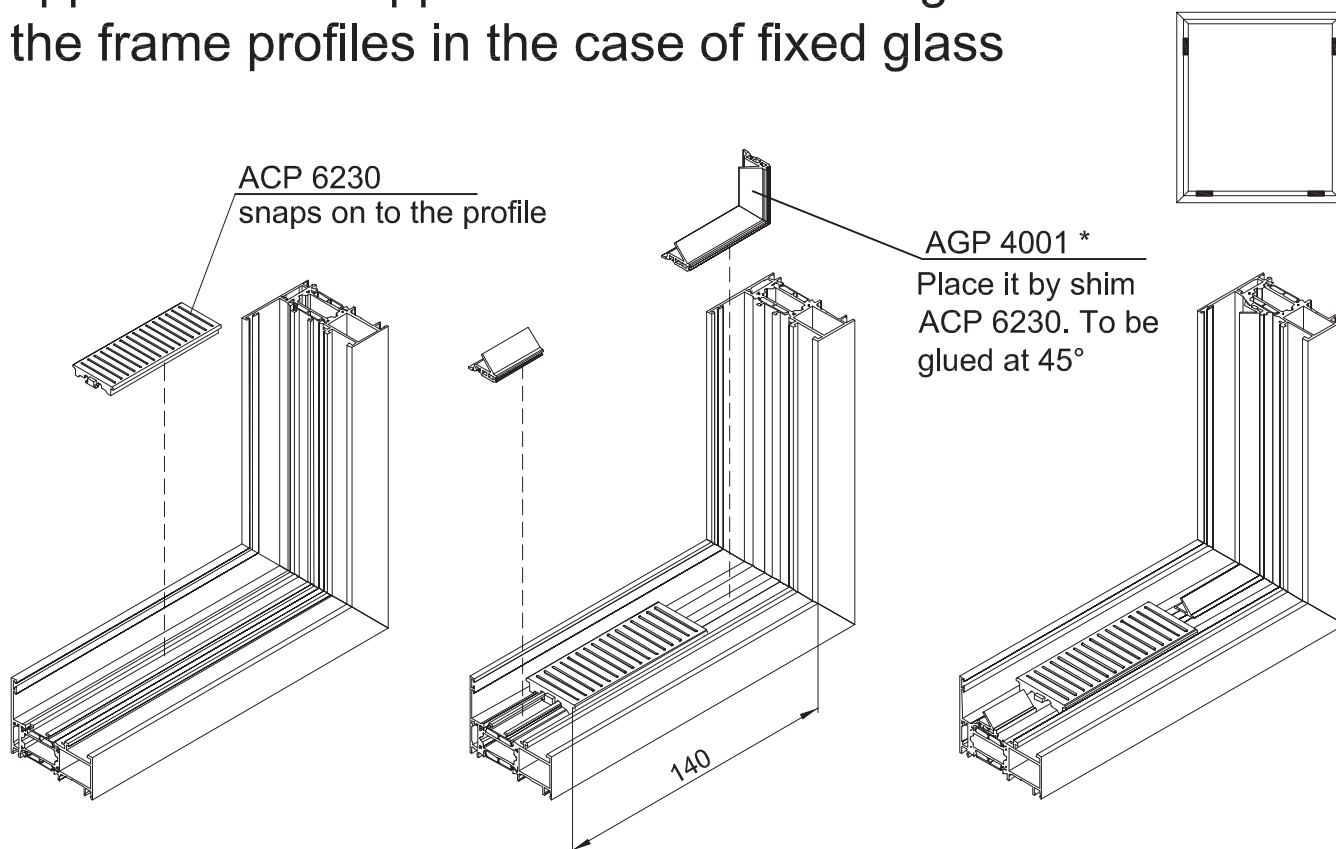

Machining of horizontal pivot reversal to fit hinge ACP 5092 – capacity 175 kg

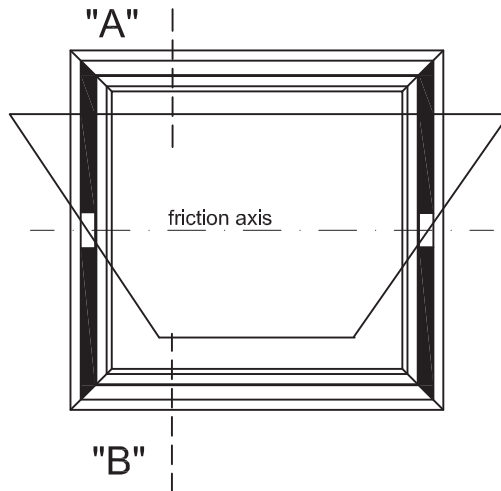
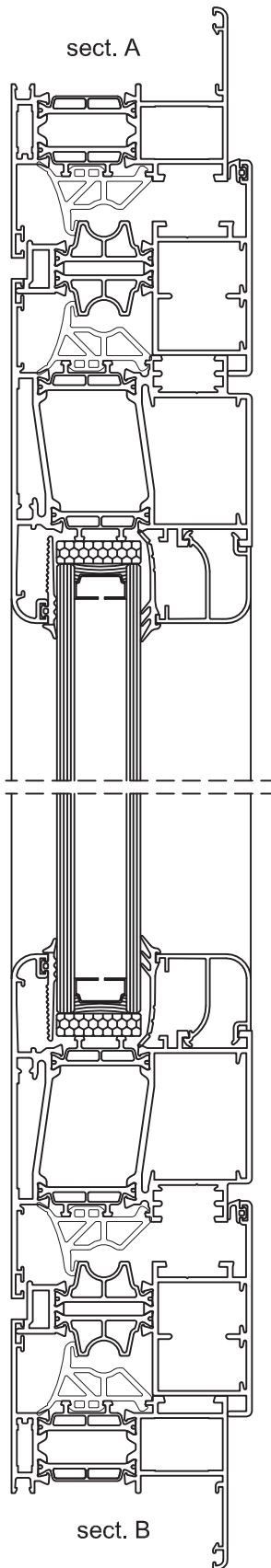

pivot reversal

Summary of cuts:

lower crosspiece:
1 piece W - 44
(45° -45°)
Point "B" - Point "B"

upper crosspiece:
1 piece W - 44
(45° -45°)
Point "A" - Point "A"

Upper jamb:
2 pieces H/2+19
(45° - 90°)
Point "A"

Lower jamb:
2 pieces H/2-21
(45° - 90°)
Point "B"

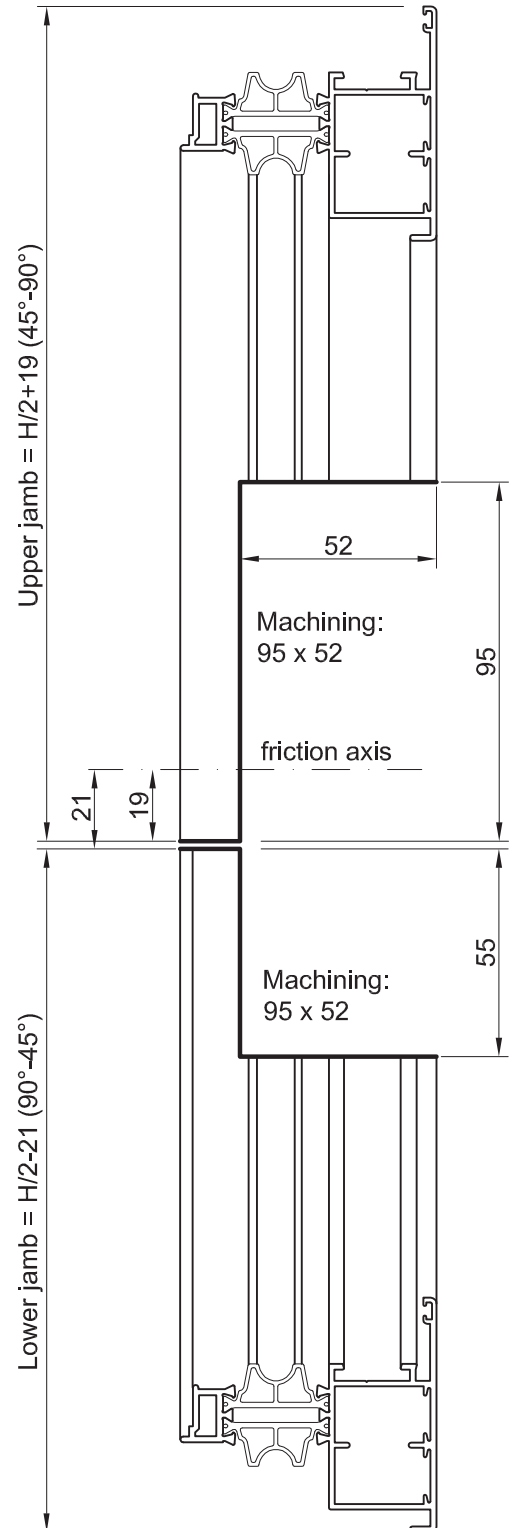
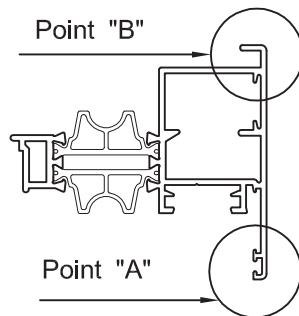

Machining of frame rod to fit kit ACP 5088 horizontal pivot

if desired, a further closure point, already included in kit ACP 5056, can be added

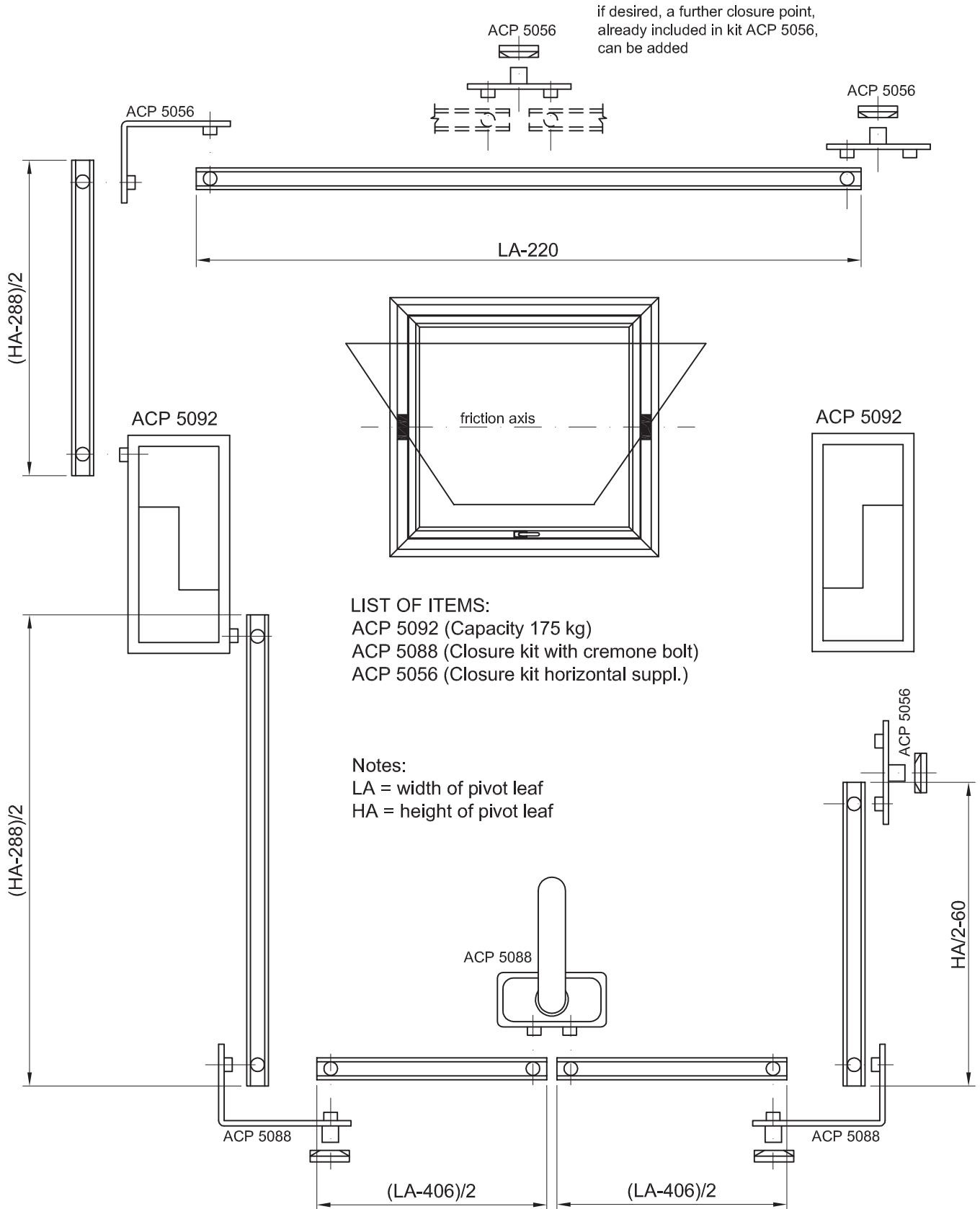

horizontal pivot

Composition of kit ACP 5088 with 4 closure points

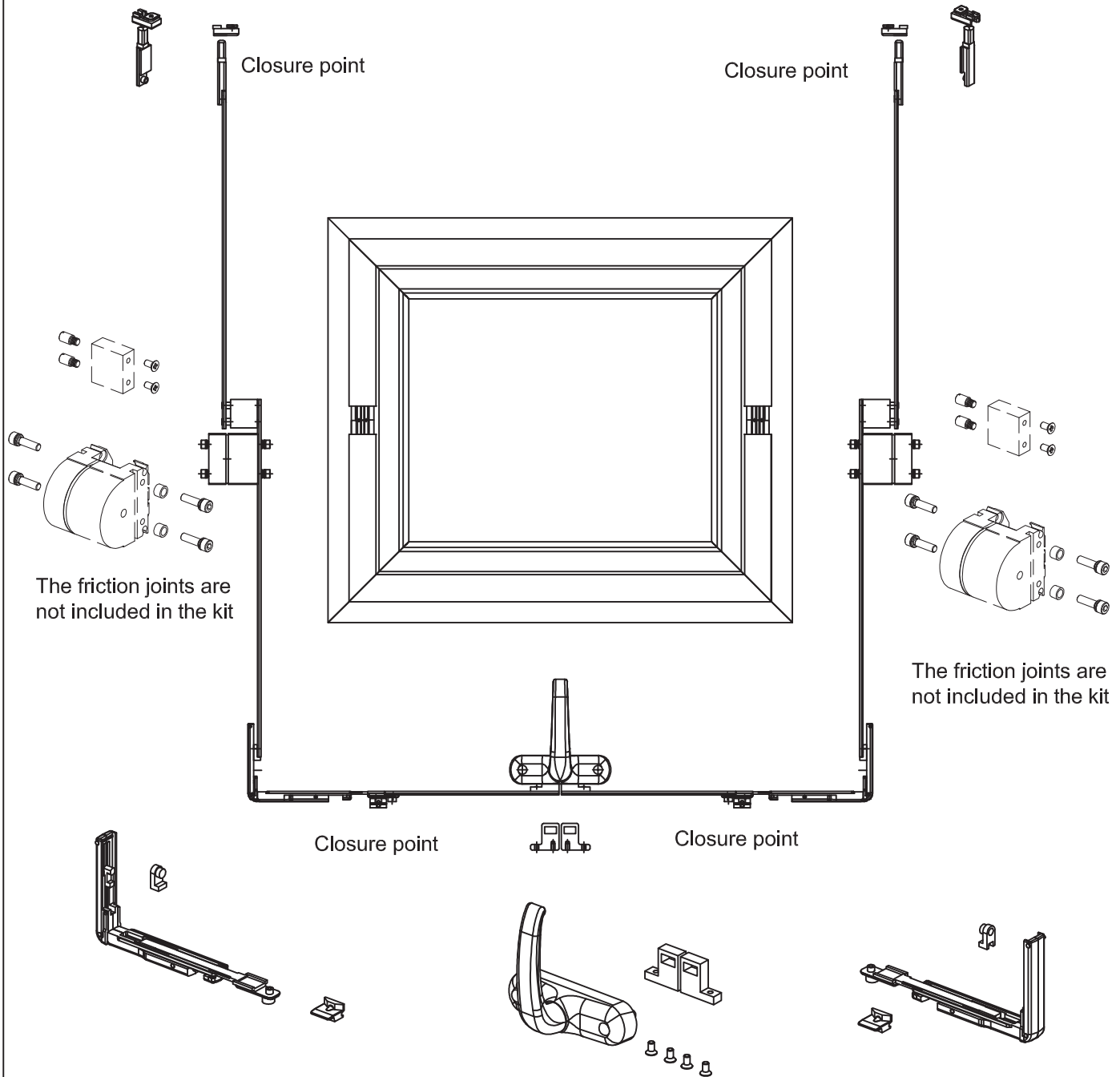

Machining of frame and vertical pivot leaf to fit hinge ACP 5092V – capacity 175 kg

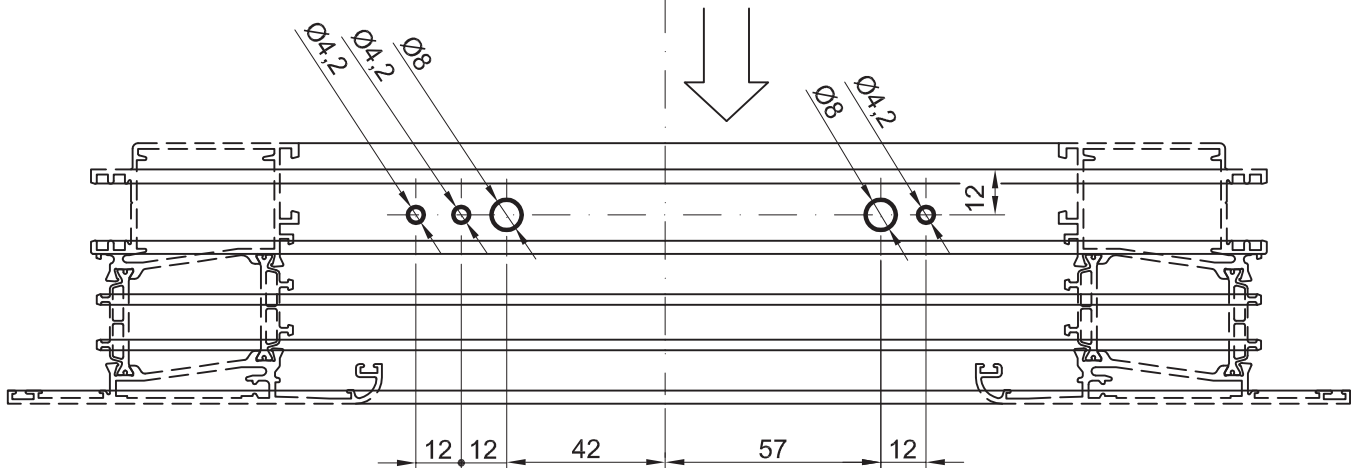
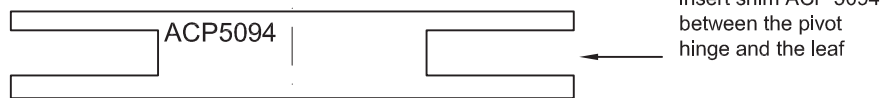
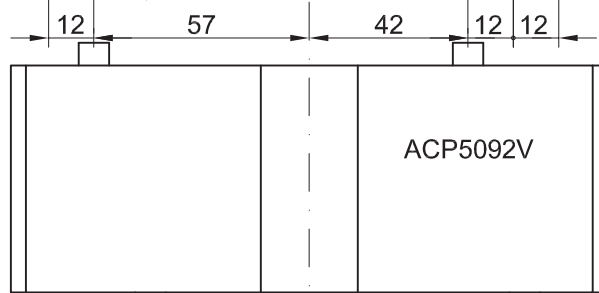
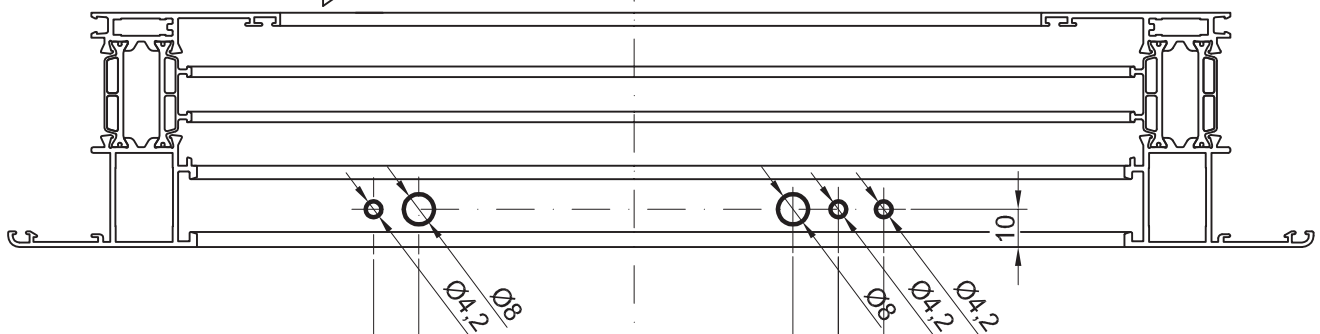
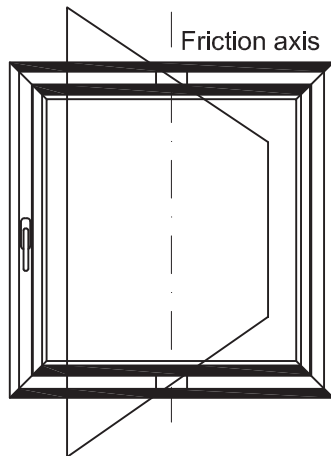

Machining of vertical pivot reversal to fit hinge ACP 5092 – capacity 175 kg

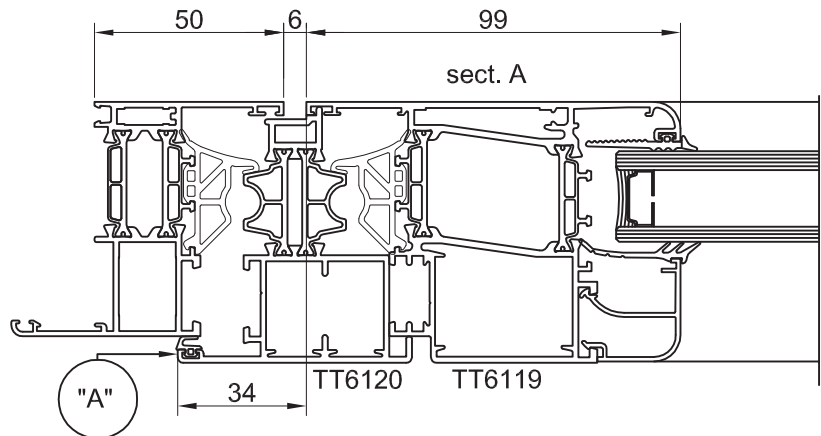
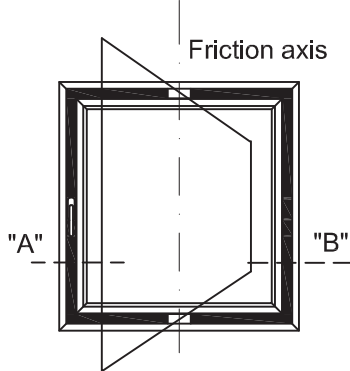

TT6120 pivot reversal

Summary of cuts:

Leaf height (HA)
Leaf width (LA)

Left jamb:
1 piece HA + 68 (45° -45°) Point "A" - Point "A"

Right jamb:
1 piece HA + 68 (45° -45°) Point "A" - Point "A"

Right crosspieces:
2 pieces LA/2 + 34 +19 (45° - 90°) Point A 45°

Left crosspieces:
2 pieces LA/2 + 34 -21(90° - 45°) Point B 45°

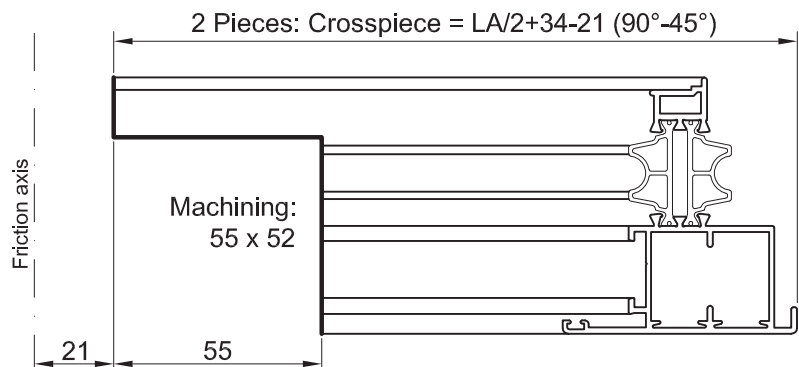
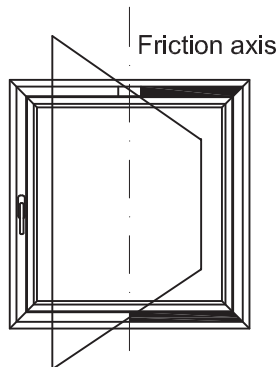
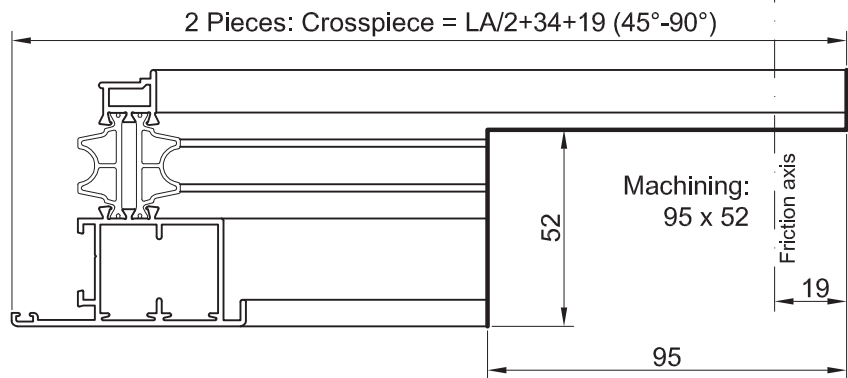
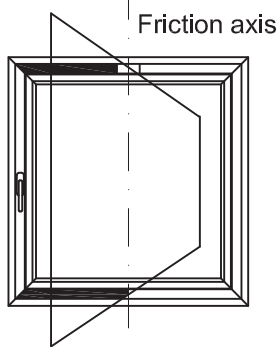
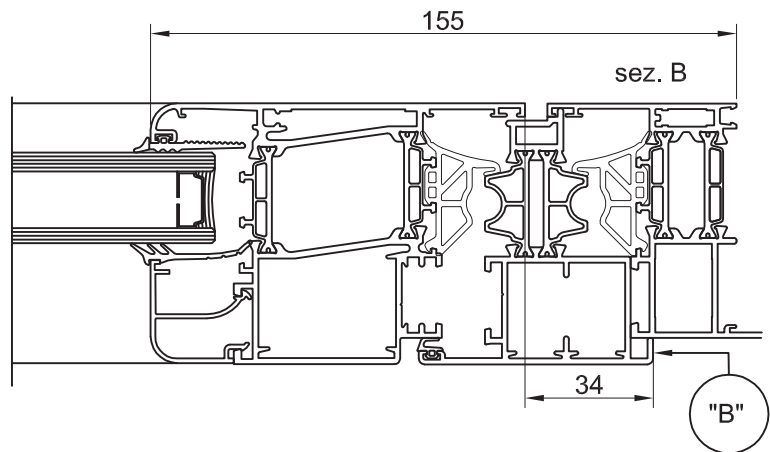

Machining of frame rod for application kit ACP 5086 vertical pivot

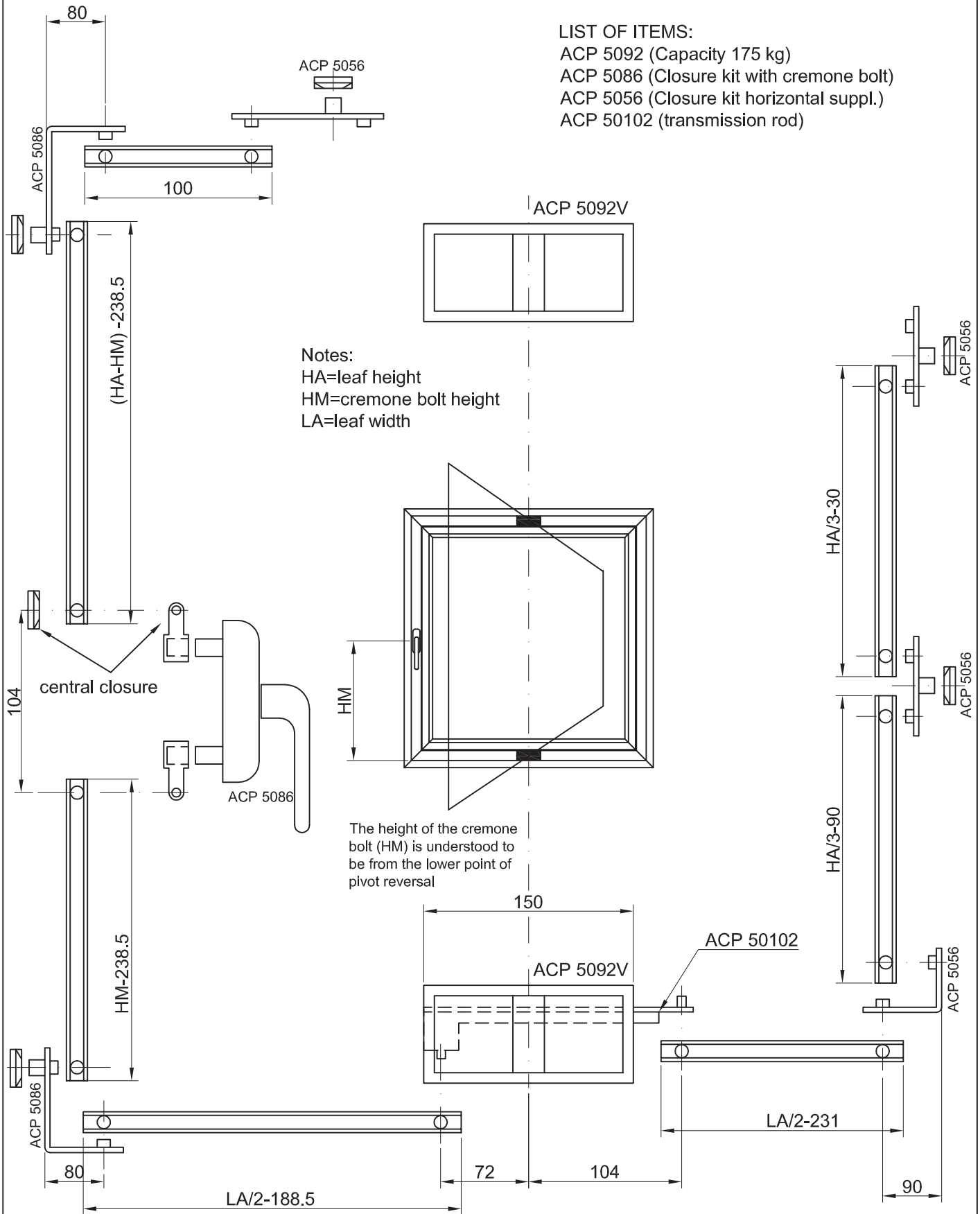

- LIST OF ITEMS:
 ACP 5092 (Capacity 175 kg)
 ACP 5086 (Closure kit with cremone bolt)
 ACP 5056 (Closure kit horizontal suppl.)
 ACP 50102 (transmission rod)

vertical pivot

Composition of kit ACP 5086 with 4 closure points

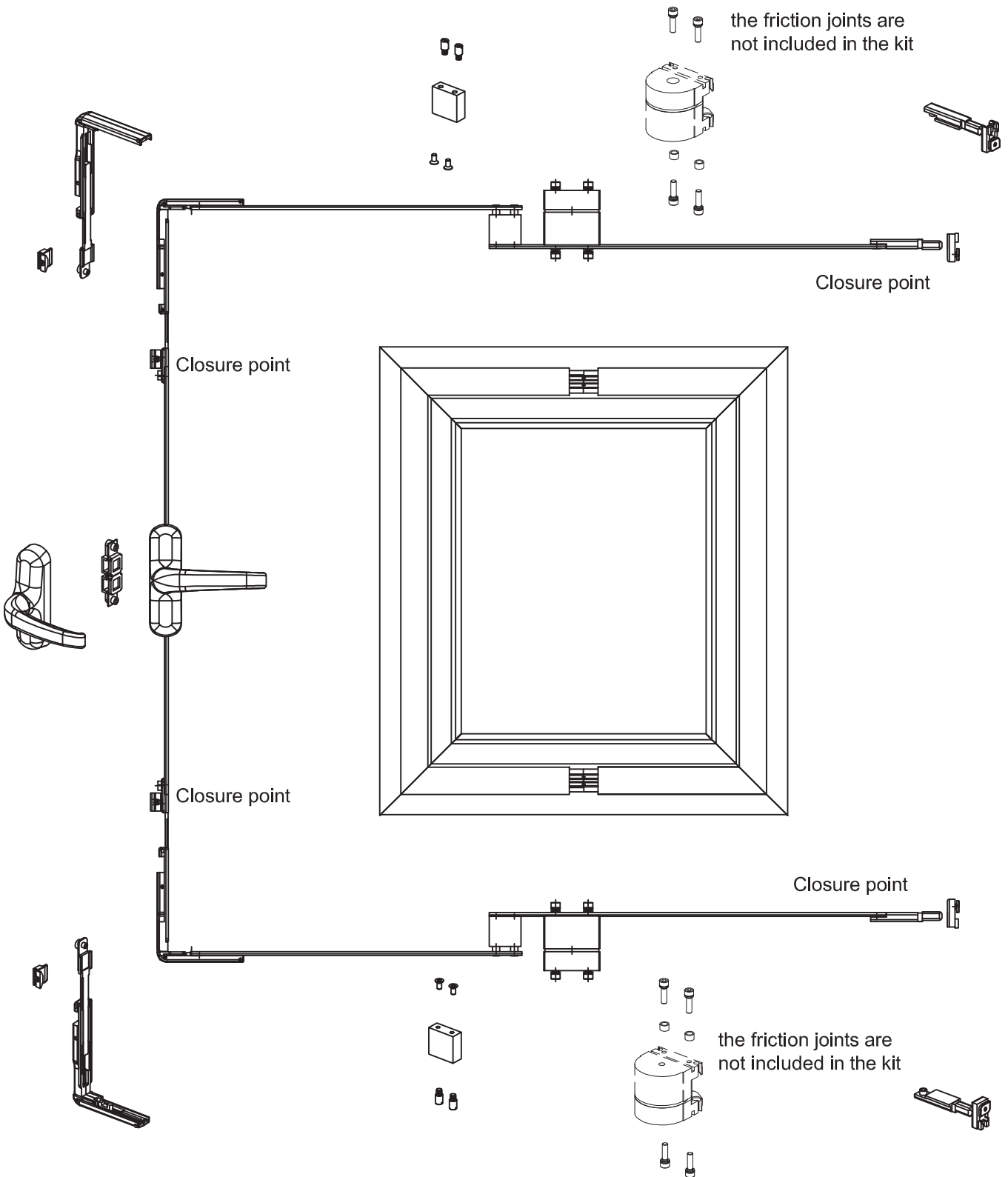

machining to fit the window handle on open-out profiles

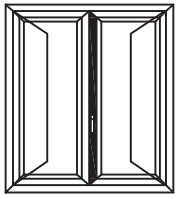

LIST OF ITEMS:

ACP 5067 (window handle control) 1 pcs.

ACP 8007 (window handle) 1 pcs.

ACP 5021 (closures) 3 pcs.

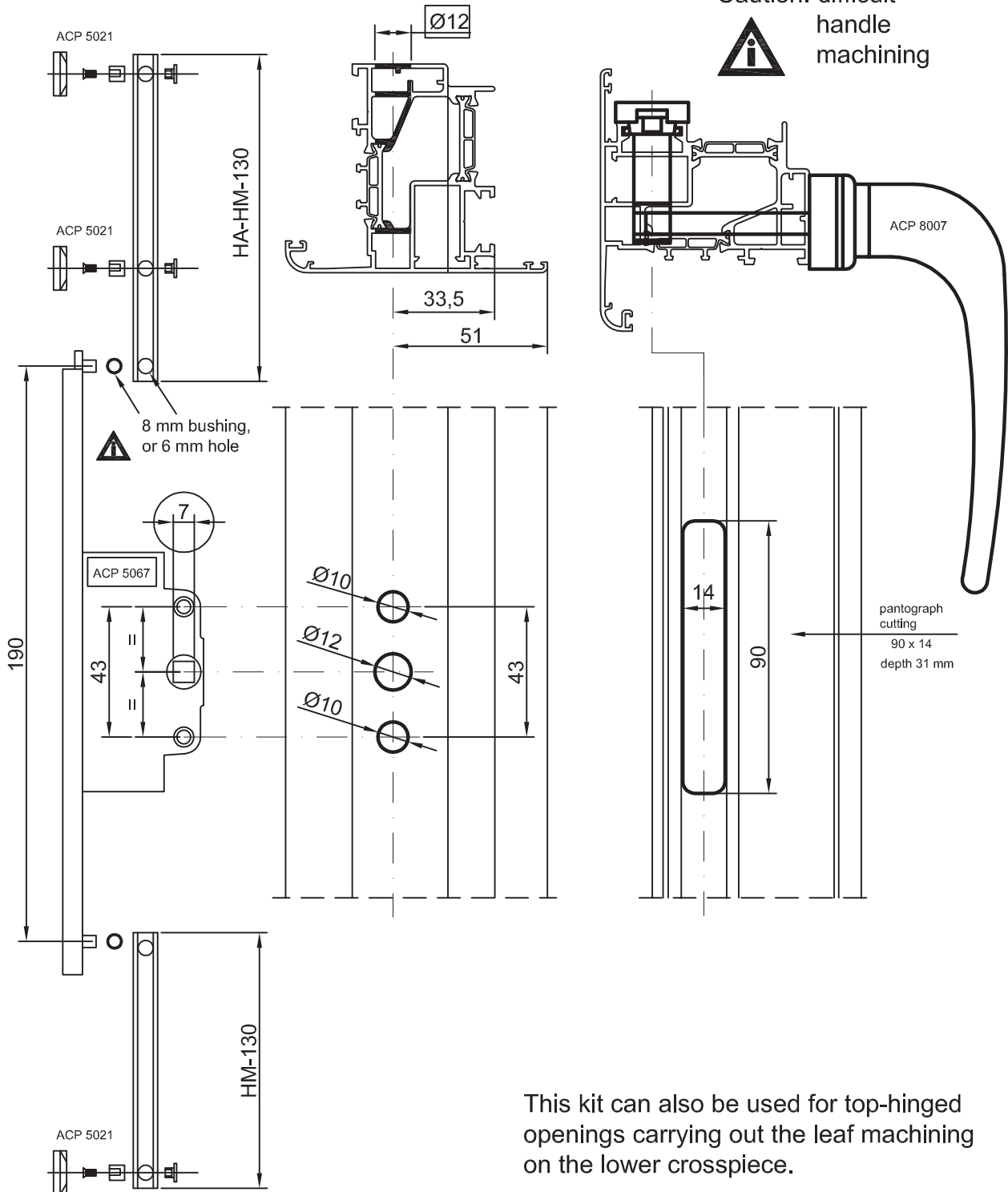

This kit can also be used for top-hinged openings carrying out the leaf machining on the lower crosspiece.

Security lock for jamb

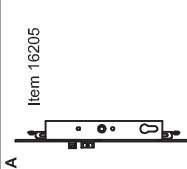
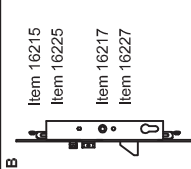
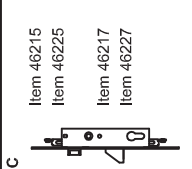
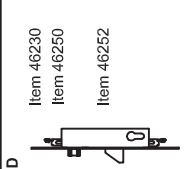
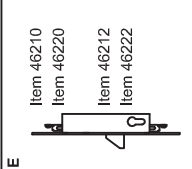
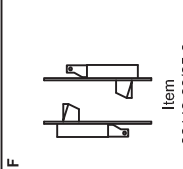
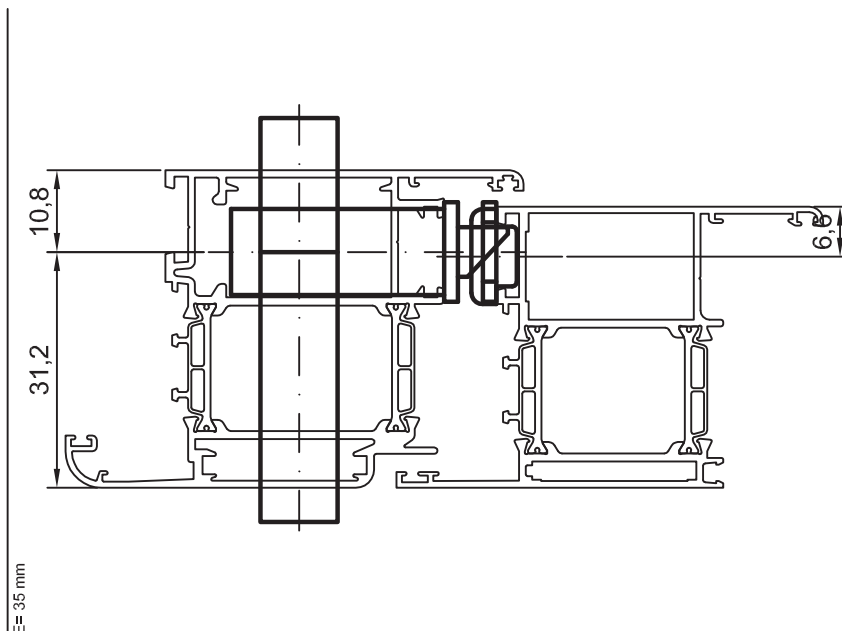
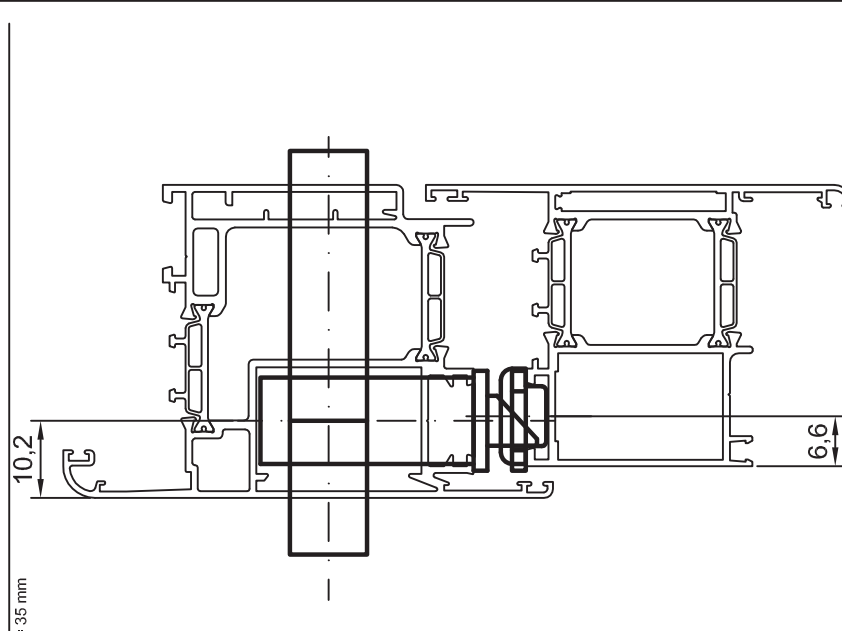
<p>A</p>  <p>Item 16205</p>	<p>B</p>  <p>Item 16215 Item 16225 Item 16217 Item 16227</p>	<p>C</p>  <p>Item 46215 Item 46225 Item 46217 Item 46227</p>	<p>D</p>  <p>Item 46230 Item 46250 Item 46252</p>	<p>E</p>  <p>Item 46210 Item 46220 Item 46212 Item 46222</p>	<p>F</p>  <p>Item 06443-00/05-0</p>																								
<table border="1"> <tr> <td colspan="2">Adjustable metal counterplate</td> <td>Front</td> </tr> <tr> <td>A-B-C</td> <td>D E-F</td> <td></td> </tr> <tr> <td>06463-22</td> <td>06465-22 (17)</td> <td></td> </tr> <tr> <td colspan="2">(17) = roller insert item 06141-71</td> <td></td> </tr> <tr> <td colspan="3">SHAPED CYLINDER (Nickel plated Fin. 12)</td> </tr> <tr> <td colspan="2">with studs</td> <td>without studs</td> </tr> <tr> <td>0E300-20</td> <td>0E300-33</td> <td>22x3</td> </tr> <tr> <td>L=80 (20,5-50,5)</td> <td>L=84 (20,5-54,5)</td> <td></td> </tr> </table>  <p>E = 35 mm</p>						Adjustable metal counterplate		Front	A-B-C	D E-F		06463-22	06465-22 (17)		(17) = roller insert item 06141-71			SHAPED CYLINDER (Nickel plated Fin. 12)			with studs		without studs	0E300-20	0E300-33	22x3	L=80 (20,5-50,5)	L=84 (20,5-54,5)	
Adjustable metal counterplate		Front																											
A-B-C	D E-F																												
06463-22	06465-22 (17)																												
(17) = roller insert item 06141-71																													
SHAPED CYLINDER (Nickel plated Fin. 12)																													
with studs		without studs																											
0E300-20	0E300-33	22x3																											
L=80 (20,5-50,5)	L=84 (20,5-54,5)																												
<table border="1"> <tr> <td colspan="2">Adjustable metal counterplate</td> <td>Front</td> </tr> <tr> <td>A-B-C</td> <td>D E-F</td> <td></td> </tr> <tr> <td>06463-22</td> <td>06465-22 (17)</td> <td></td> </tr> <tr> <td colspan="2">(17) = roller insert item 06141-71</td> <td></td> </tr> <tr> <td colspan="3">SHAPED CYLINDER (Nickel plated Fin. 12)</td> </tr> <tr> <td colspan="2">with studs</td> <td>without studs</td> </tr> <tr> <td>0E300-20</td> <td>0E300-33</td> <td>22x3</td> </tr> <tr> <td>L=80 (20,5-50,5)</td> <td>L=84 (20,5-54,5)</td> <td></td> </tr> </table>  <p>E = 35 mm</p>						Adjustable metal counterplate		Front	A-B-C	D E-F		06463-22	06465-22 (17)		(17) = roller insert item 06141-71			SHAPED CYLINDER (Nickel plated Fin. 12)			with studs		without studs	0E300-20	0E300-33	22x3	L=80 (20,5-50,5)	L=84 (20,5-54,5)	
Adjustable metal counterplate		Front																											
A-B-C	D E-F																												
06463-22	06465-22 (17)																												
(17) = roller insert item 06141-71																													
SHAPED CYLINDER (Nickel plated Fin. 12)																													
with studs		without studs																											
0E300-20	0E300-33	22x3																											
L=80 (20,5-50,5)	L=84 (20,5-54,5)																												

Security lock for jamb

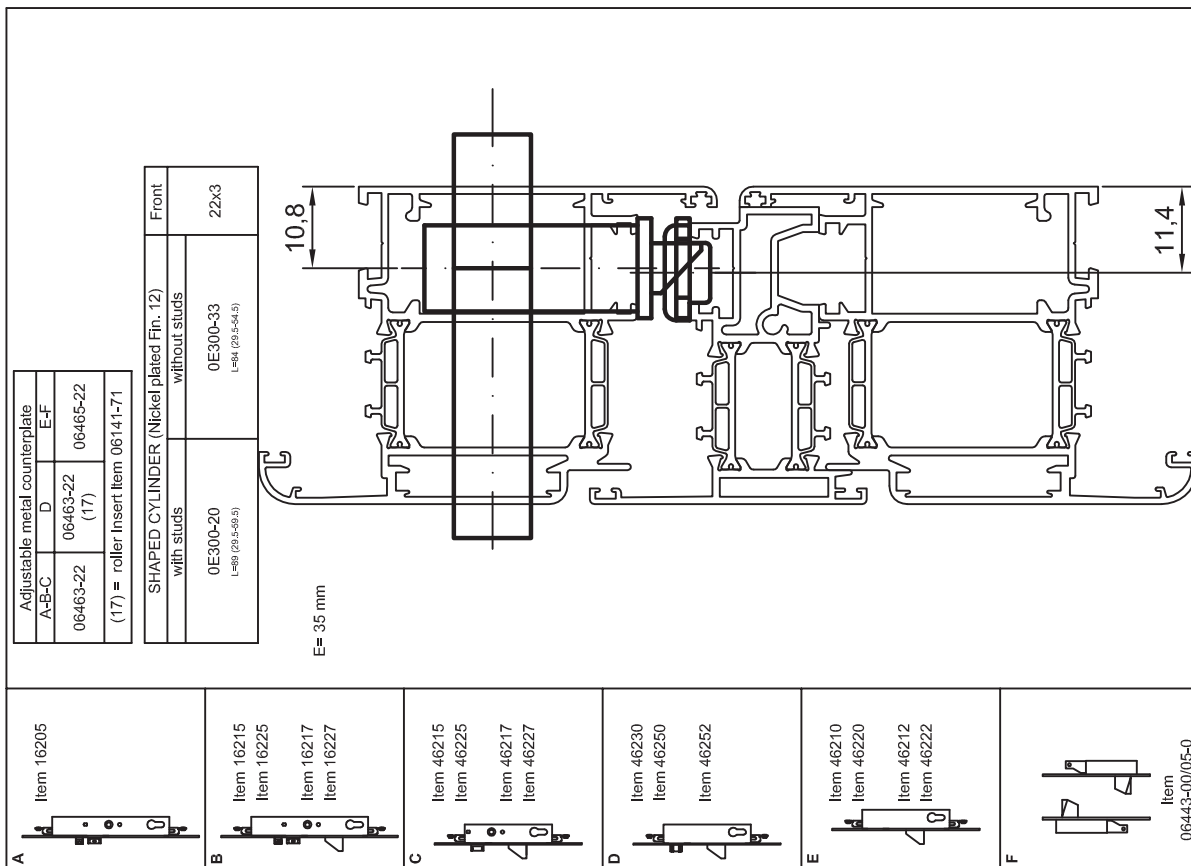
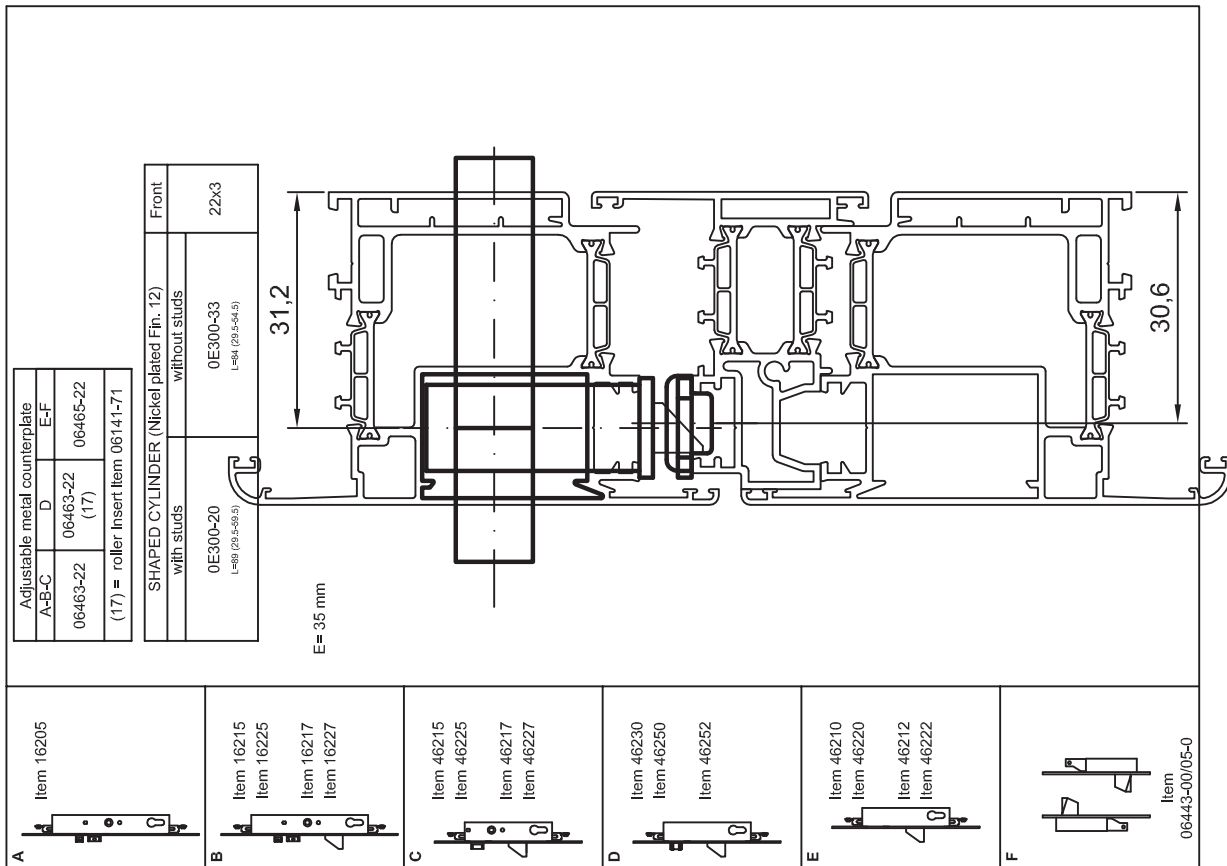

Security lock for jamb

Adjustable metal counterplate	
A-B-C	D E-F
06463-32	06465-42
(17)	(17)
(17) = roller insert item 06141-71	

SHAPED CYLINDER (Nickel plated Fin. 12)	
with studs	without studs
0E300-20 L=89 (29,5-59,5)	0E300-33 L=84 (29,5-54,5)
Front	
22x3	

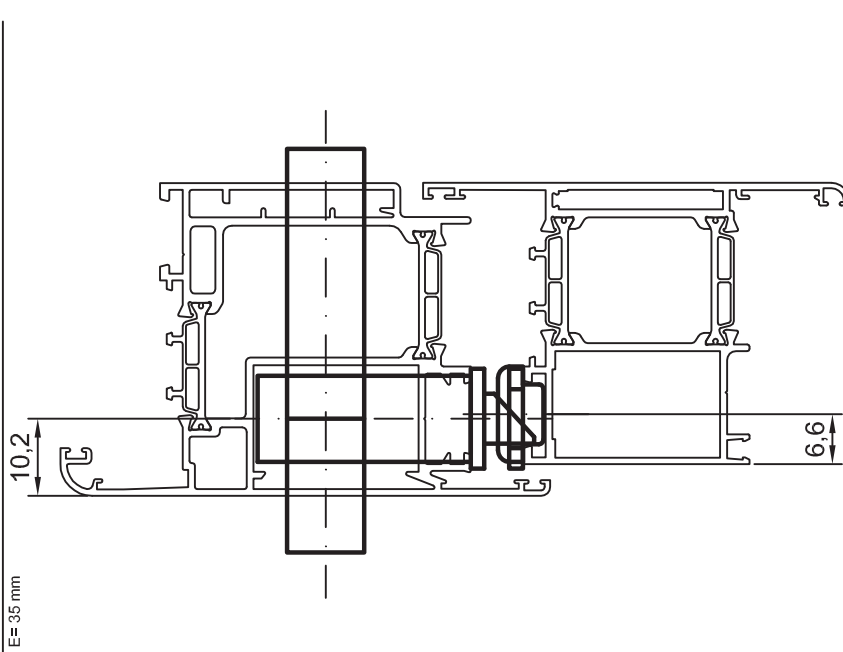

A

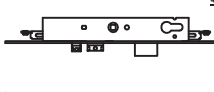

Item 18225

B

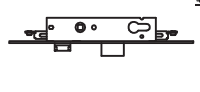

Item 48225

C

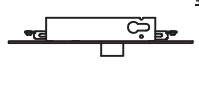

Item 48220

D

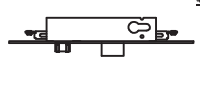

Item 48250

E

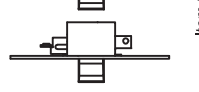

Item 06444-21-C

Adjustable metal counterplate	
A-B-C	D E-F
06463-32	06465-42
(17)	(17)
(17) = roller insert item 06141-71	

SHAPED CYLINDER (Nickel plated Fin. 12)	
with studs	without studs
0E300-20 L=89 (29,5-59,5)	0E300-33 L=84 (29,5-54,5)
Front	
22x3	

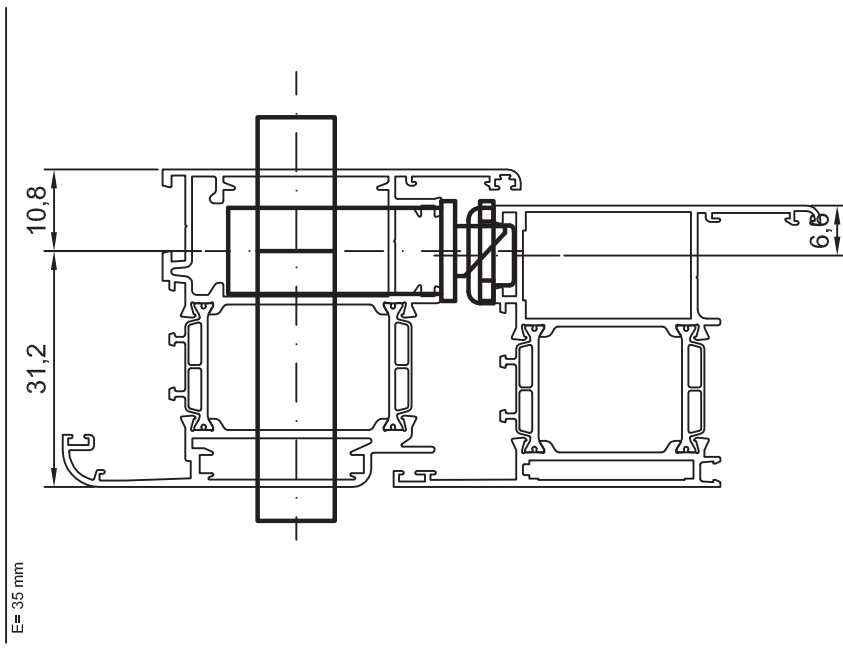

A

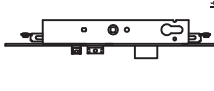

Item 18225

B

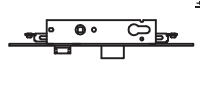

Item 48225

C

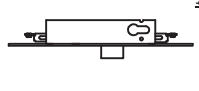

Item 48220

D

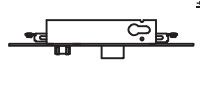

Item 48250

E



Item 06444-21-C

Security lock for jamb

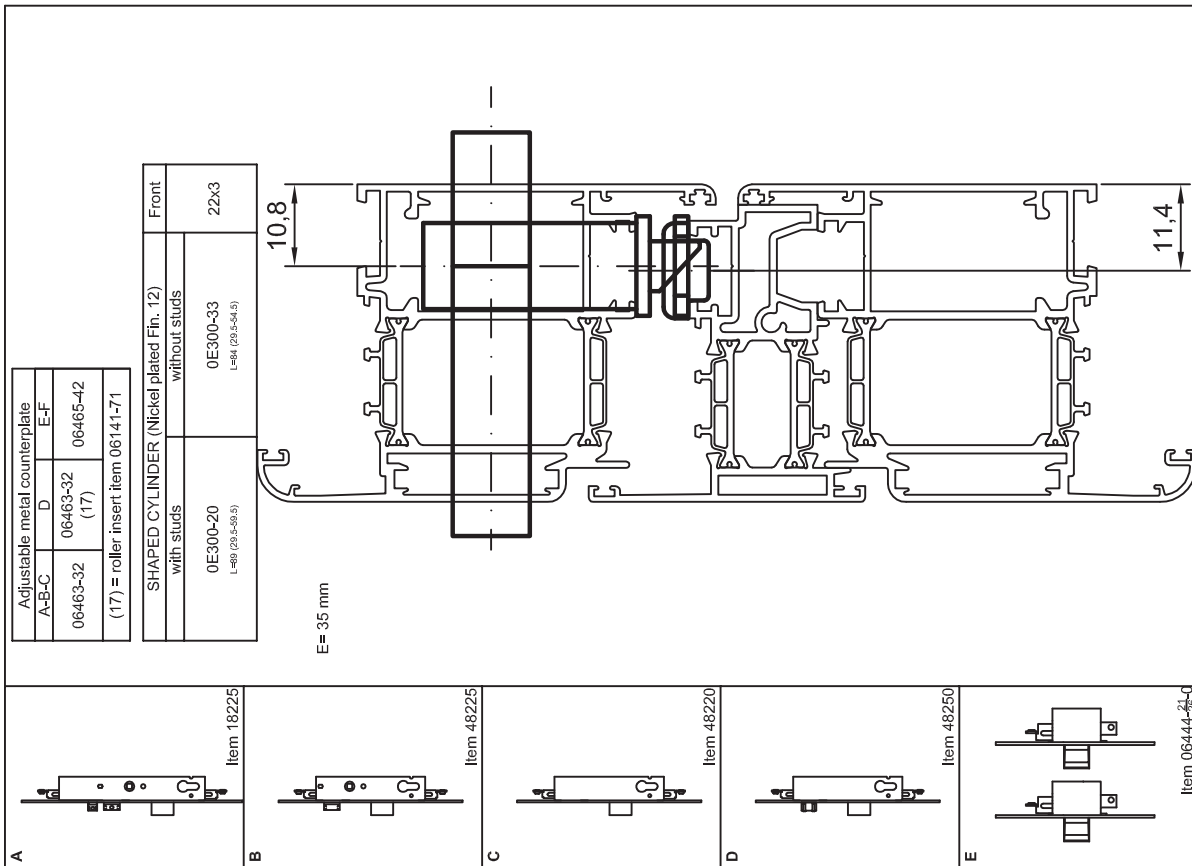
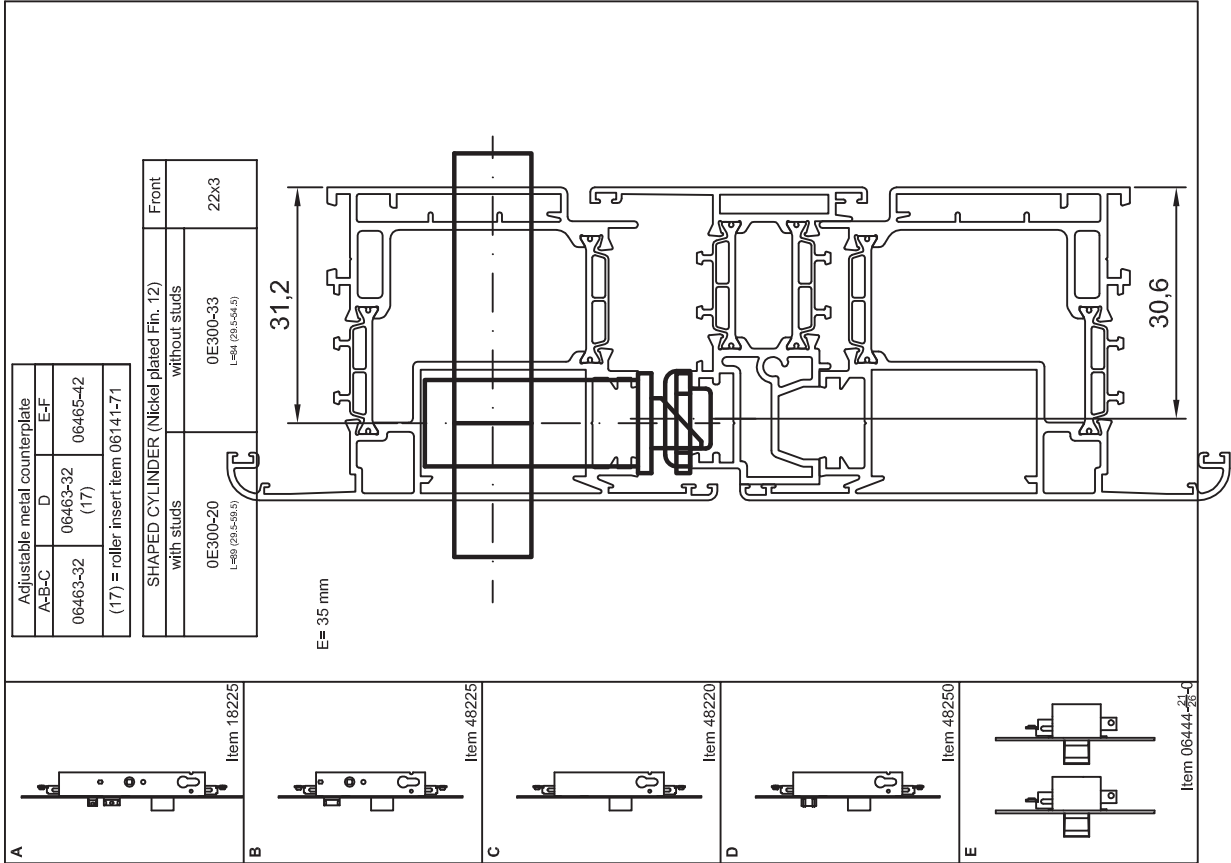

Security lock for jamb multi-point

Adjustable metal counterplate			Front
A	B	C	
06463-22	06463-22 (17)	06465-22 (pz.2)	SHAPED CYLINDER (Nickel plated Fin. 12) without studs
(17) = roller insert item 06141-71			
			0E300-33 L=84 (23,5-64,5)
			24x3

SHAPED CYLINDER (Nickel plated Fin. 12)		Front
with studs	without studs	
0E300-20 L=89 (23,5-69,5)	0E300-33 L=84 (23,5-64,5)	24x3

A

Item 16525
Item 46525

B

Item 46550

C

Item 46520

Adjustable metal counterplate			Front
A	B	C	
06463-22	06463-22 (17)	06465-22 (pz.2)	SHAPED CYLINDER (Nickel plated Fin. 12) without studs
(17) = roller insert item 06141-71			
			0E300-33 L=84 (23,5-64,5)
			24x3

SHAPED CYLINDER (Nickel plated Fin. 12)		Front
with studs	without studs	
0E300-20 L=89 (23,5-69,5)	0E300-33 L=84 (23,5-64,5)	24x3

A

Item 16525
Item 46525

B

Item 46550

C

Item 46520

Security lock for jamb multi-point

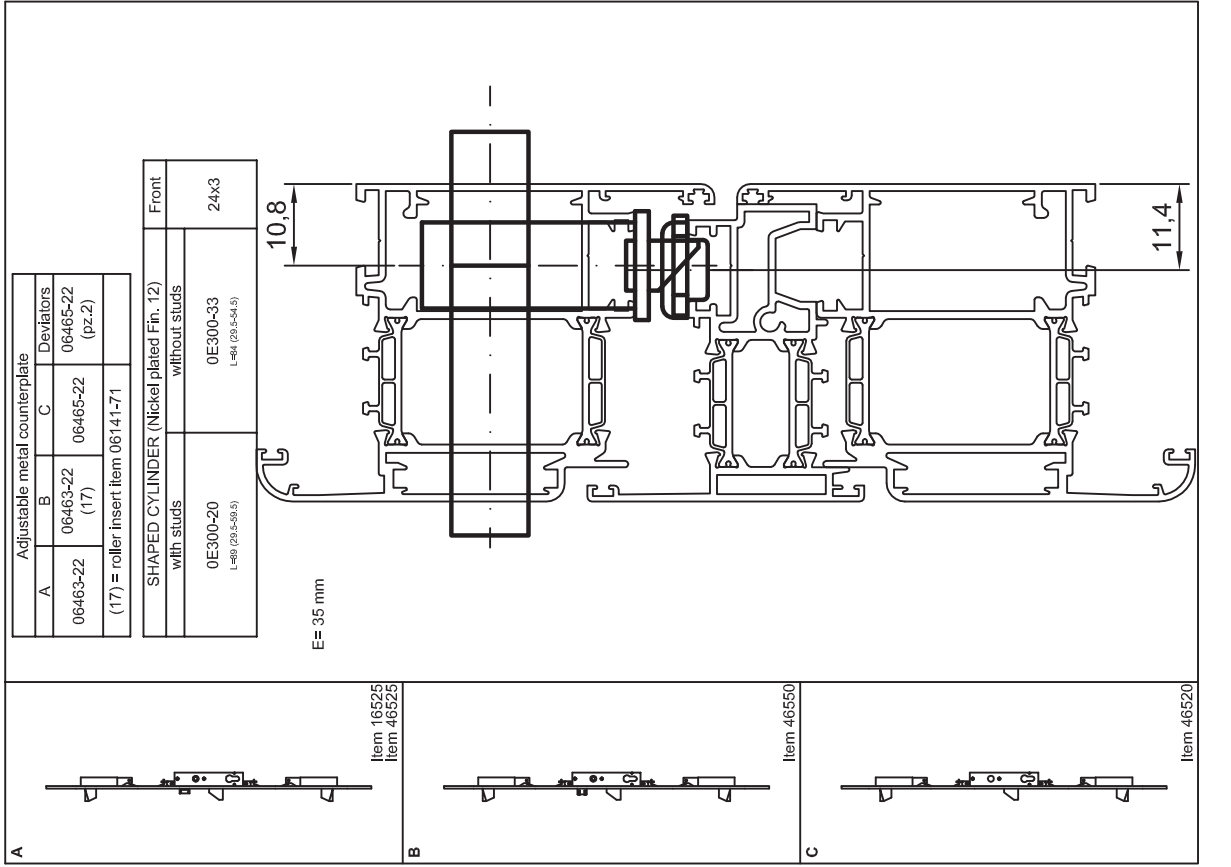
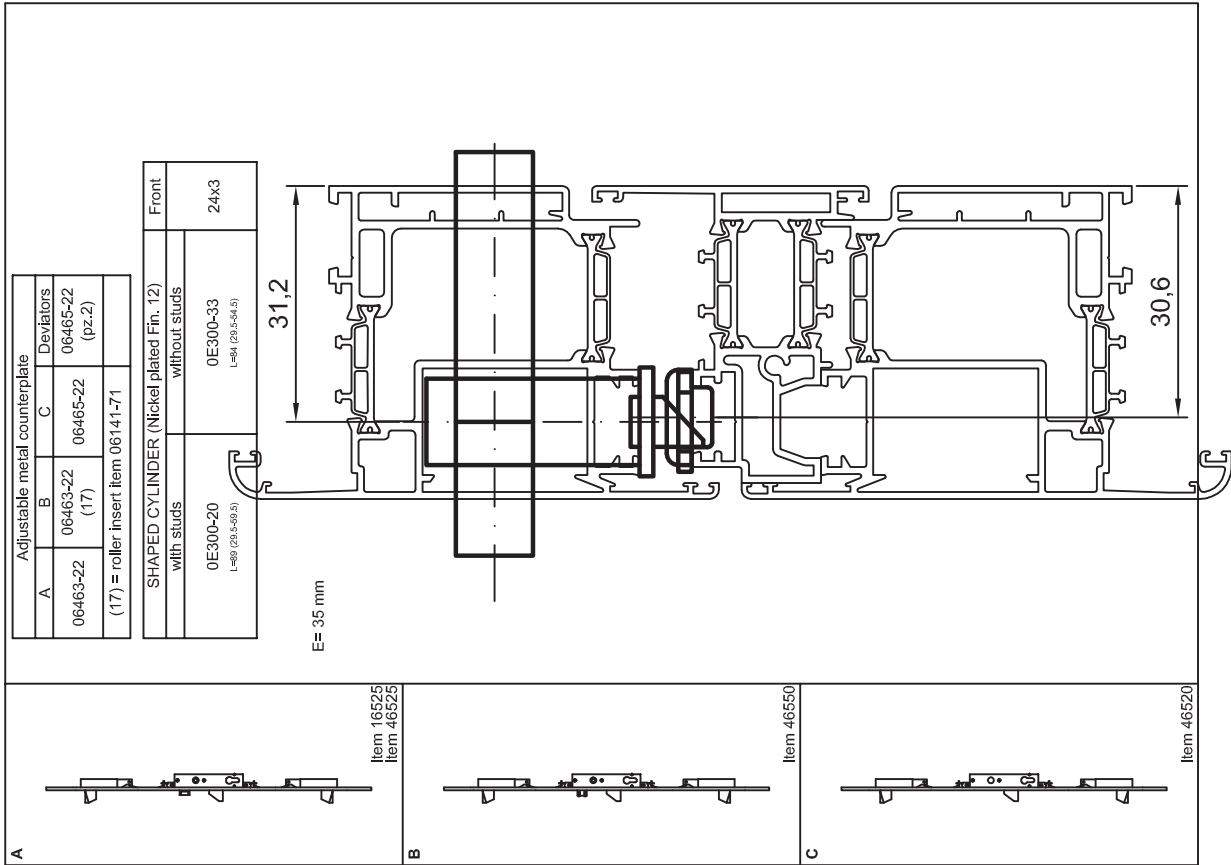

Security lock for jamb multi-point

Adjustable metal counterplate			Deviators
A	B	C	
06463-32	06463-32 (16)	06465-42	06465-42 (pz.2)
(17) = roller insert item 06141-71			

SHAPED CYLINDER (Nickel plated Fin. 12)		Front
with studs	without studs	
0E300-20 L=80 (23.5-59.5)	0E300-33 L=94 (23.5-54.5)	24x3

E= 35 mm

A

Item 18526
Item 48526

B

Item 18551

C

Item 48521

Adjustable metal counterplate			Deviators
A	B	C	
06463-32	06463-32 (16)	06465-42	06465-42 (pz.2)
(17) = roller insert item 06141-71			

SHAPED CYLINDER (Nickel plated Fin. 12)		Front
with studs	without studs	
0E300-20 L=80 (23.5-59.5)	0E300-33 L=94 (23.5-54.5)	24x3

E= 35 mm

A

Item 18526
Item 48526

B

Item 18551

C

Item 48521

Security lock for jamb multi-point

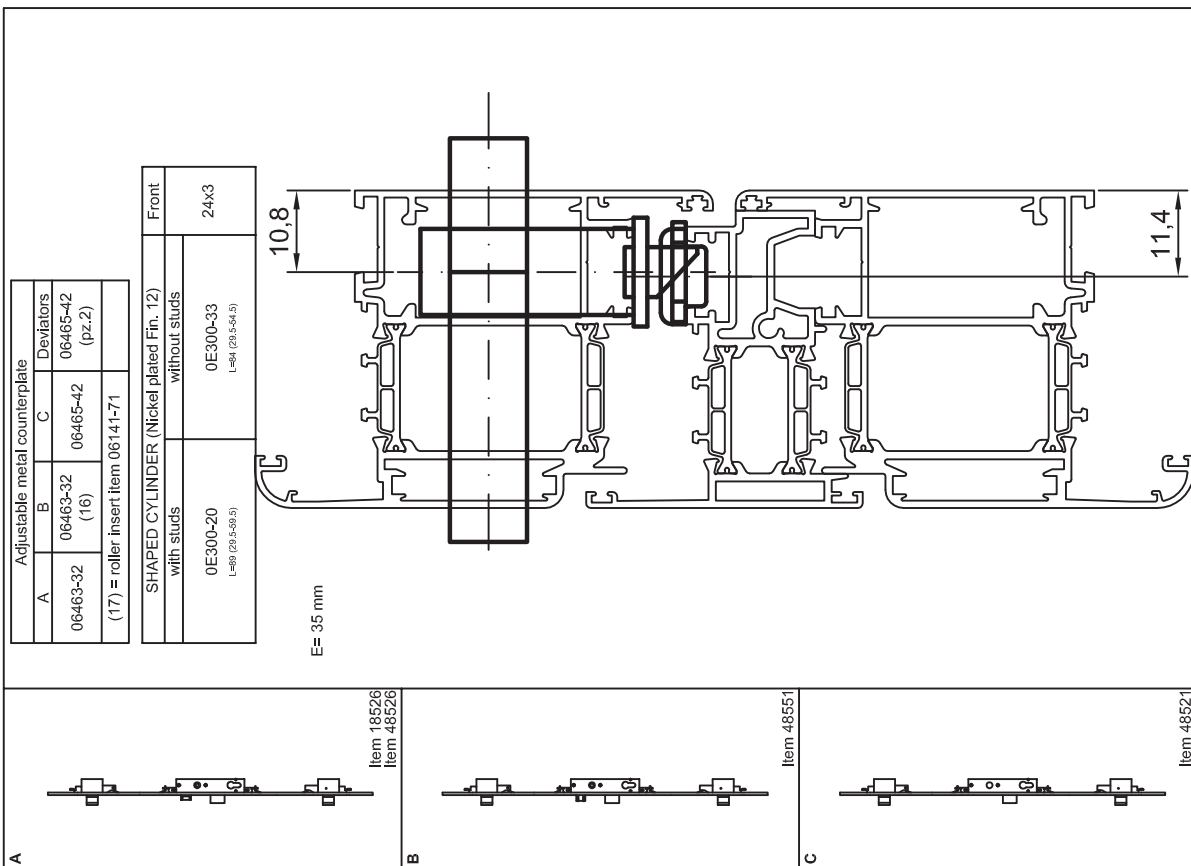
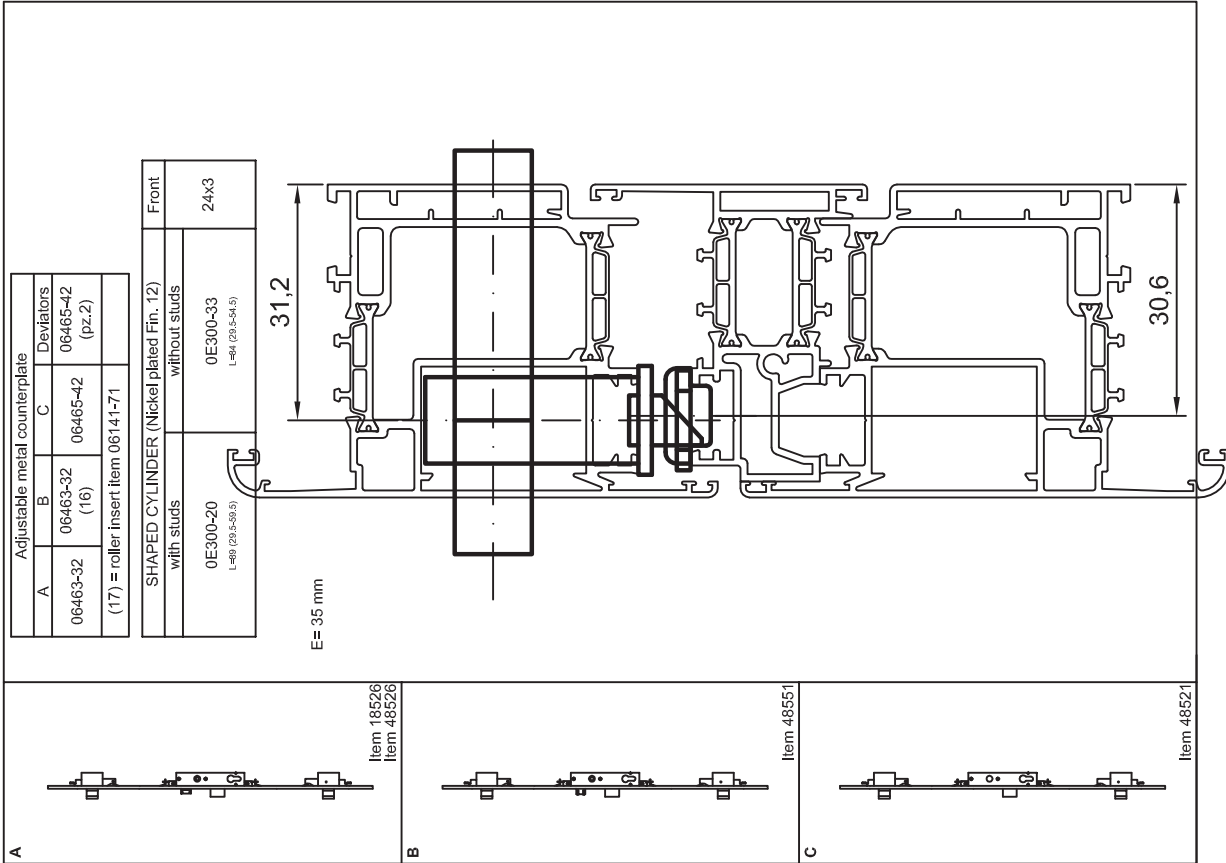

Panic exit bar

Adjustable metal counterplate		Accessories	
A	Deviators	1/2 Bar	Rods
43295-60	06465-22 (2 pcs.)	07070-66-0-B1 B/D Func.	07089-52 (Optional)
Use profile guard item		Floor Nozzle Item 06142-85	Upper Nozzle Item 06141-80
SHAPED CYLINDER (Nickel plated Fin. 12)			
with studs		without studs	
0E300-20 L=89 (29.5-59.5)		0E300-33 L=84 (29.5-54.5)	
		24x3	

N.B. The cylinder is calculated for bar 59605 and 59710; If you wish to use bar 59615 the cylinder must protrude at least 11.5mm from the edge of the internal profile

When applying the panic exit bar to the 2 leaves, it is necessary to reduce the cuts of the leaves by 1.5mm per leaf so as to leave an 8mm gap

8

30,6

E= 40mm

8

A

Item 43725 Funct. A/D
Item 43735 Funct. B

Bar panel 9mm
Item 59710-00
Item 59710-01

Handle panel
Item 07085-77-0

Bar panel 8mm
Item 59605-06

Oval Bar item
Item 07007-XX

Bar panel 8mm
Item 59615-17

Oval Bar item
Item 07007-XX

Adjustable metal counterplate		Accessories	
A	Deviators	1/2 Bar	Rods
06463-32	06465-22 (2 pcs.)	07070-66-0-B1 B/D Func.	-
Use profile guard item		Floor Nozzle item	
SHAPED CYLINDER (Nickel plated Fin. 12)			
with studs		without studs	
0E300-20 L=89 (29.5-59.5)		0E300-33 L=84 (29.5-54.5)	
		24x3	

N.B. The cylinder is calculated for bar 59605 and 59710; if you wish to use bar 59615 the cylinder must protrude at least 11.5mm from the edge of the internal profile

10,2

E= 40 mm

6,6

A

Item 43725 Funct. A/D
Item 43735 Funct. B

Bar panel 9mm
Item 59710-00
Item 59710-01

Handle panel
Item 07085-77-0

Bar panel 8mm
Item 59605-06

Oval Bar item
Item 07007-XX

Bar panel 8mm
Item 59615-17

Oval Bar item
Item 07007-XX

Security lock for central crossbeam

Adjustable metal counterplate			
A	B	C	D-E Front
06465-22	06465-22 (16)	06465-22 (pz. 3)	06465-22 (pz. 2)
(17) = roller insert item 06141-71			

SHAPED CYLINDER (Nickel plated Fin. 12)	
with studs	without studs
0E300-17 L=79 (29,5-49,5)	0E300-27 L=74 (29,5-44,5)

E= 100 mm

A

Item 56357

B

Item 56357

C

Item 06168-00
Multipoint Kit Modular
24x3

D

Item 06444-45

E

Item 06444-20-0

Adjustable metal counterplate			
A	B	C	D-E Front
06465-22	06465-22 (16)	06465-22 (pz. 3)	06465-22 (pz. 2)
(17) = roller insert item 06141-71			

SHAPED CYLINDER (Nickel plated Fin. 12)	
with studs	without studs
0E300-17 L=79 (29,5-49,5)	0E300-27 L=74 (29,5-44,5)

E= 100 mm

A

Item 56357

B

Item 56357

C

Item 06168-00
Multipoint Kit Modular
24x3

D

Item 06444-45

E

Item 06444-20-0